

Loss-tolerant operations in parity-code linear optics quantum computing

A. J. F. Hayes,* A. Gilchrist, and T. C. Ralph

Centre for Quantum Computer Technology, University of Queensland, QLD 4072, Brisbane, Australia.

(Dated: August 13, 2021)

A heavy focus for optical quantum computing is the introduction of error-correction, and the minimisation of resource requirements. We detail a complete encoding and manipulation scheme designed for linear optics quantum computing, incorporating scalable operations and loss-tolerant architecture.

PACS numbers: 42.50Dv

I. INTRODUCTION

Linear optics is a highly promising architecture in the drive to produce a quantum computer. It was first shown by Knill, Laflamme and Milburn (KLM) [1] that linear optics was a viable system for implementing scalable quantum computing [2]. Further work by various researchers has produced experimental demonstrations of some of the basic components required by linear optics quantum computing (LOQC) [3, 4, 5]. Another focus of work in the field is on improving the efficiency with which computation could be performed. An alternative scheme put forward by Nielsen [6] introduced the use of the cluster state model [7] in LOQC. A stream-lined version of this scheme can be found in the paper by Browne and Rudolph [8], which significantly decreases the size of the overheads required for computing, when compared with the original KLM design. More recently, there has been research done on the task of introducing error-correction into the cluster-state model [9, 10]. For a more extensive overview of the field of LOQC, see [11].

We have previously presented an approach to loss-tolerant active memory based on an incremental parity encoding [12, 13]. Parity encoding was used in the original KLM proposal to protect against both teleporter failures (i.e. the non-determinism of the gates) and photon loss. By using parity encoding but re-encoding incrementally (instead of by concatenation) we are able to obtain the reduction in overheads characteristic of the cluster state approach whilst retaining the circuit model and parity encoding of KLM. With the addition of a layer of redundancy encoding, this allowed for recovery from photon loss.

In this paper we will present a universal set of gates for use with a parity-based loss-tolerant code, to allow scalable quantum computing. We will show that these gates maintain loss-tolerance during operation, and calculate the loss-tolerant thresholds for computation within the scheme. Though our techniques for detecting and correcting loss are themselves also subject to loss, above a particular threshold efficiency the effect of loss can be negated to arbitrary accuracy, making the computation

loss-tolerant.

In section II we shall describe the structure of the encoding that allows us to recover from loss, and the gate operations available to us in designing a system for universal quantum computation. In this case, we assume the use of photon sources and detectors, linear optical elements, and fast feed-forward. Section III details the operations that will form a universal set of gates on the logical qubits. We demonstrate that using re-encoding to perform these gates allows recovery from losses that occur whilst attempting them. Finally, in section IV, we calculate the loss threshold for general computation, under this set of operations. These calculations deal only with loss errors, and do not consider other classes of error, such as depolarisation. We have focussed on qubit loss, as it is a dominant source of error in optics, however it should be noted that by neglecting other forms of error we are assuming that photon loss is by far the dominant source of error [14].

II. THE ENCODING

We will deal with qubits in three different tiers of encoding: (i) *physical* encoding, (ii) *parity* encoding and (iii) *redundant* encoding. At the first tier are the basic physical states that we will use to construct qubits, these will be the polarisation states of a photon so that $|0\rangle \equiv |H\rangle$ and $|1\rangle \equiv |V\rangle$. The advantage of this choice in optics, is that we can perform any single physical-qubit unitary *deterministically* with passive linear optical elements. Of course gates between different physical qubits become difficult and in LOQC these are typically non-deterministic. The function of the parity encoding is to allow near deterministic operations and to convert photon loss to heralded bit-flip errors. The redundant encoding then allows recovery from these errors.

A. Parity Encoding

We have shown how this class of code may be implemented on an arbitrary number of qubits [12]. In this paper the notation $|\psi\rangle^{(n)}$ will be used to represent a logical qubit $|\psi\rangle$ parity-encoded across n distinct physical modes each containing one photon. We describe these

*Electronic address: ahayes@physics.uq.edu.au

individual photons as the *physical qubits* that make up the system. The physical qubits also correspond to the first level of encoding.

A *parity* encoding across n photons is given by

$$\begin{aligned} |0\rangle^{(n)} &\equiv (|+\rangle^{\otimes n} + |-\rangle^{\otimes n})/\sqrt{2} \\ |1\rangle^{(n)} &\equiv (|+\rangle^{\otimes n} - |-\rangle^{\otimes n})/\sqrt{2}, \end{aligned} \quad (1)$$

where $|\pm\rangle = (|0\rangle \pm |1\rangle)/\sqrt{2}$. The $|0\rangle^{(n)}$ and $|1\rangle^{(n)}$ states have only even or odd parity terms respectively. A computational basis measurement of any one of the physical qubits will merely reduce the level of the parity encoding by one, without losing the logical qubit. A bit-flip correction may be needed dependent on the measurement result.

B. Gates at the Parity Level

The logical gates described in KLM were based on using concatenation to build up a very large resource state, and then teleporting the logical qubits in order to apply the gate operation. This method also allowed for partial loss protection to be built into the gates [15], but the resource costs were extremely high. Our alternative scheme [12], based on the same code, uses re-encoding to perform gates and has a reduced resource cost as a result.

The operation that allows us to teleport qubits or entangle states is the partial Bell state measurement [16, 17]. For qubits encoded in the polarisation modes of a photon, this operation is done by mixing two physical qubits on a polarising beam splitter followed by measurement in the diagonal-antidiagonal basis. It is successful when one photon is detected in each arm of the beam splitter's output. If both photons appear at one of the outputs, the operation has failed. The probability of success for the operation is $1/2$. When successful it projects onto the Bell states $|00\rangle \pm |11\rangle$, otherwise it projects onto the separable states $|01\rangle$ and $|10\rangle$, measuring the qubits in the computational basis. The operation can be used to attach physical qubits to a parity encoded state. This is referred to as type-II fusion (f_{II}) [8].

There are two operations which are easily performed on parity encoded states. One is a rotation by an arbitrary amount around the x -axis of the Bloch sphere (ie $X_\theta = \cos(\theta/2)I - i \sin(\theta/2)X$), which can be performed by applying that operation to any of the physical qubits; and the other is a Z operation, which can be performed by applying Z to *all* the physical qubits (since the odd-parity states will acquire an overall phase flip). This means that all the Pauli operations can be performed deterministically. The remaining gates needed in order to achieve a universal gate set are a Z_{90} and a CNOT gate. These can be efficiently performed on the parity encoded states through re-encoding.

Re-encoding is done by applying a type-II fusion between a physical qubit from the code state and a resource

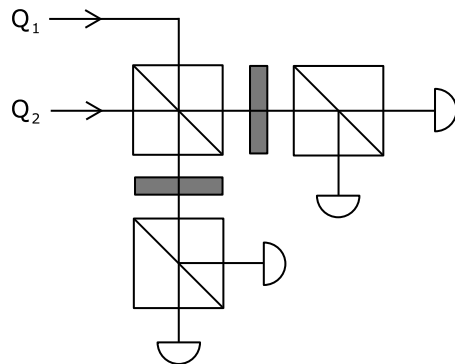

FIG. 1: This is the optical layout for a type-II fusion gate. It enacts a partial Bell measurement on two input qubits, acting as an entangling gate with a 50% probability of success.

of $|0\rangle^{(n+2)}$. The result is

$$f_{II}|\psi\rangle^{(m)}|0\rangle^{(n+2)} \rightarrow \begin{cases} |\psi\rangle^{(m+n)} & \text{(success)} \\ |\psi\rangle^{(m-1)}|0\rangle^{(n+1)} & \text{(failure)} \end{cases} \quad (2)$$

When this is successful, the length of the parity qubit is extended by n (two qubits are consumed in the operation). A phase flip correction may be necessary depending on the measurement results. Failure causes the physical qubit from the parity encoded state to be measured, lowering the level of encoding by one. The resource state is left in the state $|0\rangle^{(n+1)}$ and can be re-used.

Full details of how to enact the Z_{90} and CNOT gates can be found in Gilchrist *et al.* [18].

C. Redundant encoding

The full loss-tolerant encoding begins with a parity code of length n , and concatenates it with a redundancy code of length q . Thus at the highest level our logical qubits are given by:

$$\begin{aligned} |\psi\rangle_L &= \alpha|0\rangle_1^{(n)}|0\rangle_2^{(n)} \dots |0\rangle_q^{(n)} + \beta|1\rangle_1^{(n)}|1\rangle_2^{(n)} \dots |1\rangle_q^{(n)} \\ &= \alpha \bigotimes_q |0\rangle^{(n)} + \beta \bigotimes_q |1\rangle^{(n)} \\ &= \alpha|0\rangle^{(n,q)} + \beta|1\rangle^{(n,q)} \end{aligned} \quad (3)$$

where \bigotimes_q indicates the tensor product of q such states.

It turns out to be useful to build the following resource state:

$$|0\rangle|0\rangle^{(n,q)} + |1\rangle|1\rangle^{(n,q)} \quad (4)$$

We can create an “encoder” gate that correctly encodes from a parity qubit to a full redundancy qubit by simply fusing the resource state above onto the parity qubit. We attempt type-II fusion between this resource and the

parity qubit, $|\psi\rangle^{(n)}$, repeating until successful (on average twice) giving the (phase flip corrected) result

$$\alpha[|0\rangle^{(n-k)}|0\rangle^{(n,q)} + |1\rangle^{(n-k)}|1\rangle^{(n,q)}] + \beta[|1\rangle^{(n-k)}|0\rangle^{(n,q)} + |0\rangle^{(n-k)}|1\rangle^{(n,q)}] \quad (5)$$

where $0 < k < n - 1$ is the number of unsuccessful attempts made before fusion was achieved. This state is made up of qn “new” photons introduced by the resource and $n - k$ of the “old” photons that made up the parity qubit. By measuring the old photons in the computational basis and making a bit flip (on all-new parity qubits if needed) we obtain the expected encoded state (Eq 3).

D. Active Memory Circuit

The identity operation on the encoded state acts to detect and correct loss errors that may have occurred. Regularly performing this check can protect the quantum information from loss [13].

In this operation, one of the constituent parity qubits is sent into the encoder described earlier. With arbitrarily high probability, the encoder either successfully re-encodes the parity qubit as a full redundancy state, or it detects a loss. If a loss is detected, measurements in the diagonal basis $|0\rangle^{(n)} \pm |1\rangle^{(n)}$ can be performed on the remaining constituents of the parity qubit to disentangle it from the rest of the state. Once the logical state is no longer entangled with the lost photon, the encoding operation may be reattempted.

When the encoder succeeds, diagonal basis measurements can be used to remove the rest of the original parity qubits from the entanglement. In each case, after disentangling, it may be necessary to apply a phase-flip to return the logical qubit to the state in Eq 3. Higher levels of loss can be tolerated by increasing the size of the redundancy code. For a redundancy code of size q , it is possible to tolerate loss on up to $q - 1$ of the parity qubits, with the state being fully re-encoded from the remaining parity qubit.

III. LOGICAL GATES IN LOSS TOLERANT ENCODING

To achieve loss-tolerant quantum computing, the next step is to incorporate a full set of universal gates into the loss-tolerant memory scheme described above. We already have a universal set of gates at the level of the parity encoding [18], and these will be the basis for our development of gates for the loss-tolerant code. The key lies in finding an implementation of a universal set of gates that can be applied efficiently to qubits in this loss-tolerant encoding.

It is also necessary to ensure that the protection against loss is not compromised by these operations. As

a logical operation typically consists of a series of gates enacted on physical qubits, it is possible for losses to occur and be detected during this process. However, if the component gates have taken the logical qubit out of the code space, it may no longer be possible to correct an error. This why it is necessary to design logical operations that will not compromise the integrity of the code at any point.

In the parity encoding, we are able to perform arbitrary rotations about the x -axis (X_θ), 90-degree rotations about the z -axis (Z_{90}), and CNOT gates between qubits. These are the fundamental operations that make up a universal set at that level of encoding. Moving to the redundancy code, it can be seen that Z_θ rotations on a single parity qubit apply to the entire code, but that performing X_θ rotations would in general be significantly more difficult. Consequently, we will focus on implementing (Z_θ) and (X_{90}) at the redundancy level. However, all the Pauli gates may be performed deterministically at this level, as at the parity level of encoding.

A. The Z_θ rotation

Although performing an arbitrary Z_θ rotation on a logical qubit requires merely a Z_θ rotation on a single parity qubit within the state, such Z_θ rotations on the parity qubits are not trivial to perform. To enact a Z_θ rotation on a parity qubit using the set of gates described in [18] would require a couple of steps, during which the logical qubit is not always in a code state, and hence not properly protected from photon loss. To avoid this problem, it is necessary to change the procedure for doing an arbitrary Z_θ rotation.

Consider a general redundancy qubit $|\psi\rangle^{(n,q)}$:

$$\begin{aligned} |\psi\rangle^{(n,q)} &= \alpha|0\rangle^{(n,q)} + \beta|1\rangle^{(n,q)} \\ &= \alpha|0\rangle^{(n,q-1)}[|0\rangle_A^{(n-1)}|0\rangle_B + |1\rangle_A^{(n-1)}|1\rangle_B] \\ &\quad + \beta|1\rangle^{(n,q-1)}[|1\rangle_A^{(n-1)}|0\rangle_B + |0\rangle_A^{(n-1)}|1\rangle_B] \quad (6) \end{aligned}$$

We will require a resource state $|R_1\rangle$ to perform a logical Z_θ of the form

$$|R_1\rangle = |0\rangle^{n+1} = |0\rangle_C|0\rangle^{(n)} + |1\rangle_C|1\rangle^{(n)} \quad (7)$$

Step 1 is to perform a Z_θ rotation on a single component qubit of the redundancy state (qubit B):

$$\begin{aligned} |\psi_1\rangle &= \alpha|0\rangle^{(n,q-1)}[|0\rangle_A^{(n-1)}|0\rangle_B + e^{i\theta}|1\rangle_A^{(n-1)}|1\rangle_B] \\ &\quad + \beta|1\rangle^{(n,q-1)}[|1\rangle_A^{(n-1)}|0\rangle_B + e^{i\theta}|0\rangle_A^{(n-1)}|1\rangle_B] \quad (8) \end{aligned}$$

Step 2, a type-II fusion gate is performed between qubit B and a component qubit of the resource state (qubit C). The fusion acts to re-encode the state from the single qubit we have rotated.

$$\begin{aligned} |\psi_2\rangle &= \alpha[|0\rangle^{(n,q-1)}][|0\rangle_A^{(n-1)}|0\rangle^{(n)} + e^{i\theta}|1\rangle_A^{(n-1)}|1\rangle^{(n)}] \\ &\quad + \beta[|1\rangle^{(n,q-1)}][|1\rangle_A^{(n-1)}|0\rangle^{(n)} + e^{i\theta}|0\rangle_A^{(n-1)}|1\rangle^{(n)}] \quad (9) \end{aligned}$$

Step 3 is to measure in the computational basis the remainder of the parity qubit (A). In the event that an odd parity is measured, an X gate on the newly-added parity qubit is required as a correction.

$$\begin{aligned} \langle 0|_A^{(n-1)}|\psi_2\rangle : \\ |\psi_3\rangle &= \alpha|0\rangle^{(n,q-1)}|0\rangle^{(n)} + \beta|1\rangle^{(n,q-1)}e^{i\theta}|1\rangle^{(n)} \\ &= \alpha|0\rangle^{(n,q)} + e^{i\theta}\beta|1\rangle^{(n,q)} \end{aligned} \quad (10)$$

$$\begin{aligned} \langle 1|_A^{(n-1)}|\psi_2\rangle : \\ |\psi_4\rangle &= e^{i\theta}\alpha|0\rangle^{(n,q-1)}|1\rangle^{(n)} + \beta|1\rangle^{(n,q-1)}|0\rangle^{(n)} \end{aligned} \quad (11)$$

$$\begin{aligned} X|\psi_4\rangle : \\ |\psi_5\rangle &= \alpha|0\rangle^{(n,q)} + e^{-i\theta}\beta|1\rangle^{(n,q)} \end{aligned} \quad (12)$$

It can be seen that the result of an odd parity measurement is a rotation of the form $Z_{-\theta}$. In this case the logical gate must be re-attempted, using $Z_{2\theta}$. It is worth noting that the logical Z_{180} operation can be performed deterministically, and hence that a Z_{90} gate would only need to be attempted once regardless of the outcome of the measurement.

For a general Z_θ gate, an average of two attempts would be required. The advantage this method holds for our purposes is that the redundancy qubit will always be left in a code state, maintaining the protection against loss.

B. The X_{90} rotation

For a universal set of gates, an X_{90} gate is also required. To enact the X_{90} gate, the operation is performed on one of the component physical qubits. It is then possible to re-encode from this physical qubit in a similar manner to that used for the Z_θ gate. Measurement of the old qubits will once again allow us to determine an appropriate set of corrections.

As before, we begin by considering a general redundancy qubit $|\psi\rangle^{(n,q)}$ (Eq. 6). A larger resource state $|R_2\rangle$ is required for the logical X_{90} gate:

$$|R_2\rangle = |0\rangle_C|0\rangle^{(n,q)} + |1\rangle_C|1\rangle^{(n,q)} \quad (13)$$

We then proceed as before, step 1 being an X_{90} rotation on one component qubit (B). Step 2 is to perform a fusion gate between that qubit and the qubit labelled as C in the resource state. In step 3, it is necessary to measure all the old qubits which made up the original redundancy state. Those qubits in the parity state from which the rotated qubit came (A) are measured in the computational basis. All others (D) are measured in the diagonal basis. Corrections will depend on the overall parity of the qubits measured computationally, and on whether an odd number of the other parity qubits are measured in the $|-\rangle$ state.

The possible states after measurement are:

$$\begin{aligned} \langle 0|_A\langle +|_D|\psi\rangle : \\ |\psi_6\rangle &= (\alpha - i\beta)|0\rangle^{(n,q)} - i(\alpha + i\beta)|1\rangle^{(n,q)} \\ \langle 1|_A\langle +|_D|\psi\rangle : \\ |\psi_7\rangle &= (\beta - i\alpha)|0\rangle^{(n,q)} - i(\beta + i\alpha)|1\rangle^{(n,q)} \\ \langle 0|_A\langle -|_D|\psi\rangle : \\ |\psi_8\rangle &= (\alpha - i\beta)|0\rangle^{(n,q)} + i(\alpha + i\beta)|1\rangle^{(n,q)} \\ \langle 1|_A\langle -|_D|\psi\rangle : \\ |\psi_9\rangle &= (\beta - i\alpha)|0\rangle^{(n,q)} + i(\beta + i\alpha)|1\rangle^{(n,q)} \end{aligned} \quad (14)$$

Accordingly, we may require a logical X gate, a logical Z gate, or both in order to correct the resulting state. Once any necessary corrections are performed, we are left with a redundancy state on which the X_{90} operation has been successfully applied.

C. Logical CNOT

It was explained earlier in this paper that a logical CNOT gate could be enacted on a parity qubit by a process of encoding. The CNOT is performed between two redundancy qubits, $|\psi\rangle$ and $|\phi\rangle$. Here $|\psi\rangle$ is the control and $|\phi\rangle$ is the target.

$$|\psi\rangle_L = \alpha|0\rangle^{(n,q)} + \beta|1\rangle^{(n,q)} \quad (15)$$

$$|\phi\rangle_L = \gamma|0\rangle^{(n,q)} + \delta|1\rangle^{(n,q)} \quad (16)$$

The logical CNOT gate is performed as an iterative process, with a parity-level CNOT performed for each parity qubit in $|\psi\rangle$. Each of these parity-level CNOT gates will use an arbitrary parity qubit from $|\phi\rangle$ as its target input.

We use the following resource for each iteration.

$$\begin{aligned} |R_3\rangle &= |0\rangle_C|0\rangle^{(n)}(|0\rangle^{(m)}|0\rangle_D + |1\rangle^{(m)}|1\rangle_D) \\ &+ |1\rangle_C|1\rangle^{(n)}(|1\rangle^{(m)}|0\rangle_D + |0\rangle^{(m)}|1\rangle_D) \end{aligned} \quad (17)$$

where $m = \lfloor n/2 \rfloor$. It consists of two parity qubits with a CNOT already performed between them. The target parity qubit, m , is shorter since re-encoding is not required on the second logical qubit.

Step 1 of the process is then to fuse a member of the selected parity qubit from $|\psi\rangle$ with qubit C in the resource, $|R_3\rangle$.

If this is successful, step 2 is to measure the remaining original physical qubits in the parity state, to complete the re-encoding. If a loss is detected anywhere up to this point, we disentangle the chosen parity qubit and the resource from the rest of the $|\psi\rangle$ state using diagonal basis measurements. This allows us to recover and re-attempt the process.

In step 3, perform a fusion gate between qubit D in the resource and a physical qubit taken from $|\phi\rangle$. To recover from a loss, should one occur during this fusion, we disentangle the resource from $|\psi\rangle$ by making diagonal basis

measurements on it, and do the same for the parity qubit in $|\phi\rangle$ on which we have acted. Once again, Z and/or X gates may be required as corrections on both qubits depending on the outcome of the measurements. These Pauli gates can be applied deterministically to parity or redundancy states. To perform the full logical CNOT, this process is iterated for each parity qubit in $|\psi\rangle$.

These encoding-based gate operations continually replace the photons used for the logical qubits, and the old photons are measured, identifying any losses that arise. In this way, loss detection and correction are continually applied during computation.

IV. LOSS-TOLERANT THRESHOLDS

In order for the encoding to be useful in a scalable quantum computing scheme, it is necessary to show that a loss threshold exists. If the loss is below this threshold, it is possible to drive the probability of failure arbitrarily close to zero by increasing the size of the code. We will first summarize the threshold calculation for the identity operation, as presented in our previous paper [13]. We then present a revised threshold for general computation, using the logical gate operations we have described.

A. A Loss-Tolerance Threshold for the Active Memory

The active memory scheme is used to protect an encoded logical qubit $|\Psi\rangle^{(n,q)}$, by regularly re-encoding it using the resource given in Eq 4. We begin by considering the probability of loss for each photon. The efficiency of the photon source will be labelled η_s , and the efficiency of the detectors will be η_d . We will use η_m to indicate the memory efficiency, which is the probability a photon will *not* be lost during the time it is in memory, in-between re-encoding cycles. This means that the probability of detecting a new photon, from a resource state, is $\eta_2 = \eta_s\eta_d$, and the probability of detecting an old photon, from the code state, is $\eta_1 = \eta_s\eta_m\eta_d$. Note that fusing a resource onto a logical qubit will succeed or fail with probability $\eta_1\eta_2/2$ and detect a photon loss with probability $1 - \eta_1\eta_2$.

In calculating the loss-tolerant threshold for the encoding, we consider the possible outcomes of an attempt to re-encode the state. For a given parity qubit in the overall state, there are three possible outcomes when attempting to re-encode from it.

The first possible outcome is successful re-encoding without loss. This occurs when the fusion is successful on one of the first $n - 1$ physical qubits in the parity state, and the remainder are measured in the computational basis without loss. The probability for this is:

$$P_{Qs} = \sum_{i=1}^{n-1} \left(\frac{1}{2}\eta_1\eta_2\right)^i \eta_1^{n-i} \quad (18)$$

Note that if only one component qubit remains in the parity state, we instead measure it in the diagonal basis to disentangle it, and begin again with another parity qubit from the overall state.

The second outcome that can occur is total failure. This can result from a long series of losses and/or fusion failures. The probability for total failure is:

$$P_{ff} = \sum_{j=1}^{n-1} \left(\frac{1}{2}\eta_1\eta_2\right)^{j-1} (1 - \eta_1\eta_2)(1 - \eta_1)^{n-j} \\ + R \sum_{j=0}^{n-2} \left(\frac{1}{2}\eta_1\eta_2\right)^{j+1} \sum_{k=0}^{n-2-j} \eta_1^k (1 - \eta_1)^{n-1-j-k} \\ + \left(\frac{1}{2}\eta_1\eta_2\right)^{n-1} (1 - \eta_1) \quad (19)$$

$$R = \sum_{k=1}^q \binom{q}{k} (1 - \eta_2)^{kn} [1 - (1 - \eta_2)^n]^{q-k} \quad (20)$$

Here R is the probability of failing to recover via measurements on the new resource qubits. This can occur when photon loss is detected after a fusion has been performed, and attempts to disentangle by measuring components of the original parity qubit have proven unsuccessful.

The third possibility is that of recovery after partial failure. The probability of this can be calculated from the previous two equations: $P_{Qf} = 1 - P_{Qs} - P_{ff}$. We can tolerate this outcome occurring up to $q-1$ times when attempting to re-encode. Therefore, the total probability for successfully re-encoding is:

$$P_E = \sum_{j=0}^{q-1} P_{Qf}^j P_{Qs} [1 - (1 - \eta_1)^n]^{q-1-j} \quad (21)$$

where the $[1 - (1 - \eta_1)^n]^{q-1-j}$ factor occurs because it is necessary to disentangle the remainder of the original state once the chosen parity qubit has been successfully re-encoded.

For the probability P_E to approach one for large encodings, it is necessary to maintain a particular ratio between n and q . The optimal ratio can be found by solving $\frac{d}{dq} P_E = 0$ for q in terms of n . This relationship is shown in figure 2. In these calculations, we considered an equally high error rate in all parts of the circuit ($\eta_s = \eta_m = \eta_d = \eta$). Using the optimal ratio, we found numerically that P_E can be driven arbitrarily close to one when $\eta \geq 0.82$. This is shown in figure 3.

B. A Loss-Tolerance Threshold for Computation

The thresholds for the single-qubit logical gates are the same as the threshold for the identity (memory) case, due to the strong similarity between the gate operations, and the re-encoding used in the active memory. The Z_θ operation uses smaller resources, and as such has a slightly

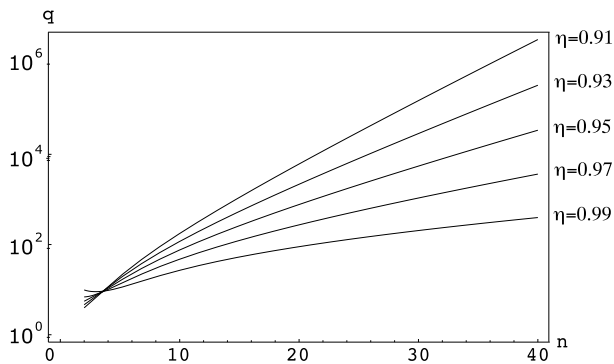

FIG. 2: Variation of the optimal value of q with n , for given values of η

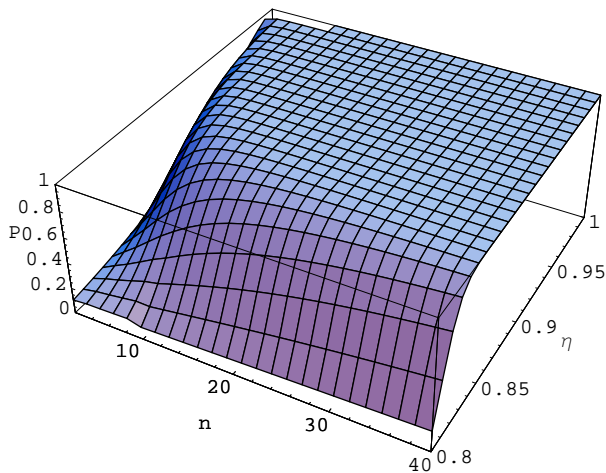

FIG. 3: Probability of success for active memory using optimal q as a function of η and n

higher probability of success, but this difference becomes vanishingly small for large code sizes. This results in it having the same threshold as the X_{90} operation, and the identity. The CNOT gate is the most complicated of the universal set of gates we have developed, and we would expect it to be the most vulnerable to loss.

The probability of successfully performing our CNOT gate without loss can be evaluated by considering three possible outcomes for each iteration in the procedure. These consist of a no-progress outcome, in which a CNOT between parity qubits fails due to loss or measurement errors, a progress outcome, in which the CNOT is successful, and total failure, in which one or both logical qubits are lost. There are several ways in which a no-progress outcome can occur. These events and their probability are listed below.

1. Fusion attempts are unsuccessful, and the chosen parity qubit is disentangled from the rest of the state:

$$M_1 = \left(\frac{1}{2}\eta_1\eta_2\right)^{n-1}\eta_1 \quad (22)$$

2. A loss occurs during a fusion attempt, and the parity qubit is disentangled:

$$M_2 = \sum_{i=0}^{n-2} \left(\frac{1}{2}\eta_1\eta_2\right)^i (1-\eta_1\eta_2)[1 - (1-\eta_1)^{n-i-1}] \quad (23)$$

3. A loss occurs while measuring off qubits after a successful fusion, and the parity qubit is disentangled:

$$M_3 = \sum_{i=1}^{n-2} \left(\frac{1}{2}\eta_1\eta_2\right)^i \sum_{j=0}^{n-i-2} \eta_1^j (1-\eta_1)[1 - (1-\eta_1)^{n-i-j-1}] \quad (24)$$

4. A loss occurs while measuring off qubits after a successful fusion, the parity qubit is not disentangled, and it is necessary to measure the resource in order to disentangle it:

$$M_4 = \sum_{i=1}^{n-1} \left(\frac{1}{2}\eta_1\eta_2\right)^i \sum_{j=0}^{n-i-1} \eta_1^j (1-\eta_1)^{n-i-j} [(1 - (1-\eta_2)^n)(1 - (1-\eta_2)^{\frac{n}{2}+1})] \quad (25)$$

5. A loss occurs during fusion with the target qubit, which is measured in order to disentangle it:

$$M_5 = \sum_{i=1}^{n-1} \left(\frac{1}{2}\eta_1\eta_2\right)^i \eta_1^{n-i} (1-\eta_1) \left(\frac{1}{2}\eta_1\eta_2\right) (1 - (1-\eta_1)^{\frac{n}{2}+1}) \quad (26)$$

For most of these events, it is necessary to re-encode the logical control qubit afterwards to ensure it is fully protected. This has a probability of success of P_E .

Hence the probability of a no-progress outcome (M) is:

$$M = P_E \sum_{k=1}^4 M_k + M_5 \quad (27)$$

Here P_E is the probability of successfully re-encoding a logical qubit, as shown earlier. The probability of a progress outcome (K) is:

$$K = \sum_{i=0}^{n-1} \left(\frac{1}{2}\eta_1\eta_2\right)^i \eta_1^{n-i} \left[\frac{1}{2}\eta_1\eta_2 + (1-\eta_1\eta_2)(1 - (1-\eta_1)^{n-1})(1 - (1-\eta_2)^{\frac{n}{2}})\right] \quad (28)$$

For a gate between two logical qubits, each made up of q parity qubits, the overall probability of success is:

$$P_{TOTAL} = \left(\frac{K}{1-M}\right)^q \quad (29)$$

To simplify the calculation, we again consider the case in which the different parts of the system (sources, memory/manipulation, detectors) contribute equally to the loss. We represent the efficiency of each of these components as η . Using the equations shown, we can examine

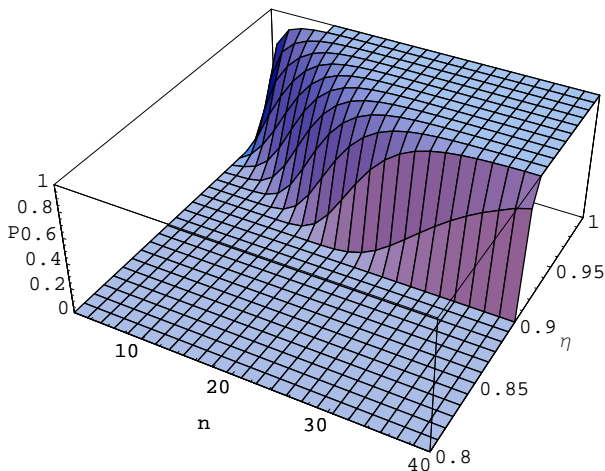

FIG. 4: Probability of success for a logical CNOT gate on redundancy qubits

the way the probability of success varies with this efficiency (figure 4). It is assumed the $n : q$ ratio of these logical qubits will be optimised for re-encoding, using the formula found earlier.

It can be seen that the threshold approaches a value of 90% efficiency for the CNOT gate. So far, we have assumed an equal contribution to the loss from different components. However, if we assume that one or more parts of the system are lossless (e.g. perfect detectors), the thresholds for the rest of the system will drop accordingly.

V. RESOURCES

The procedures we have described require many entangled resource states to be prepared separately for use in computation. We assume our basic building blocks for these resources to be maximally-entangled Bell pairs, in the state $|0\rangle^{(2)}$. Such Bell pairs would have to be generated directly from a heralded source, or created from single photons via a KLM-style entangling gate [1].

The first step in creating the resources required is to generate larger parity states, of the form $|0\rangle^{(n)}$. These states are built up iteratively by fusing smaller parity states together, in a similar manner to that used to generate cluster states [8]. Initially, it is necessary to use a type-I fusion gate, which acts as a single-rail partial Bell measurement. As in the case of the type-II fusion gate, both input qubits are mixed at a 50-50 beamsplitter. However, only one arm is measured. The type-I gate is successful when exactly one photon is found in this arm. To achieve the desired fusion operation for combining parity states, Hadamard gates are performed on the inputs and output of the type-I fusion gate. This operation has the advantage that only one qubit is mea-

sured, but a failure means that both parity states are completely lost.

$$(H \otimes H) f_I H |0\rangle^{(n)} |0\rangle^{(m)} \rightarrow \begin{cases} |0\rangle^{(m+n-1)} & \text{(success)} \\ - & \text{(failure)} \end{cases} \quad (30)$$

As a result, the type-I fusion gate is used to create short parity qubits, which are then joined in larger chains using type-II fusion 2. The type-II fusion measures one qubit from each state, but does not destroy the state in the event of failure, allowing resources to be recycled. Additionally, if one of the input qubits to the type-II gate is missing the loss will be detected, reducing loss errors due to gates in the entanglement construction. For effi-

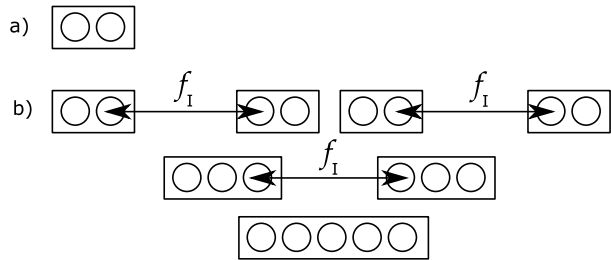

FIG. 5: (a) A representation of the two-qubit parity state used as a starting resource, $|0\rangle^{(2)}$. (b) The process by which larger parity states are generated, using fusion gates between qubits.

cient resource production, states of the form $|0\rangle^{(5)}$ could be produced using type-I fusion, as shown in figure 5. This would require an average of 16 Bell pairs. In order to generate larger states, the type-II fusion gate should be used to join multiple copies of the $|0\rangle^{(5)}$ state.

To create redundantly encoded resources, we begin by performing a CNOT between a pair of physical qubits taken from the states $|0\rangle^{(n+1)}$ and $|0\rangle^{(n)}$. If successful, this will produce the state

$$|0\rangle|0\rangle^{(n,2)} + |1\rangle|1\rangle^{(n,2)} \quad (31)$$

which can be used to encode a qubit $|\Psi\rangle$ in the logical state $|\Psi\rangle^{(n,2)}$. To build a larger redundancy resource, we fuse multiple copies of the state given by Eq. 31.

VI. CONCLUSIONS

In this paper we have given a full description of a redundancy code for performing circuit-based linear optical quantum computing in the presence of photon loss. We have found that the code is successful as a quantum memory if each potential area of loss (the photon source, the memory/operational section of the circuit, and the detectors) has an efficiency of 82% or greater. For general computation in this system, the threshold efficiency

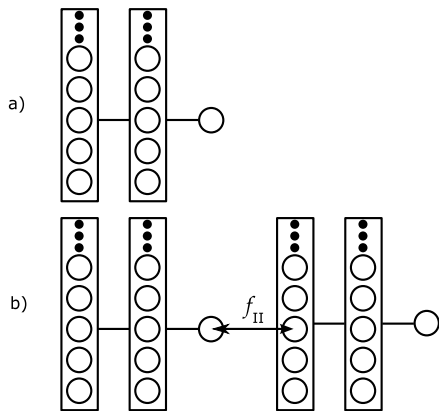

FIG. 6: (a) A graphical representation of the state $|0\rangle|0\rangle^{(n,2)} + |1\rangle|1\rangle^{(n,2)}$ (equation 31). (b) A fusion between two such states. Once the remainder of the parity qubit being encoded has been measured in the computational basis, the resulting state is $|0\rangle|0\rangle^{(n,3)} + |1\rangle|1\rangle^{(n,3)}$.

is 90%, as this is the minimum efficiency which will allow all the gate operations to work successfully. For both of these thresholds, an efficiency less than the threshold in an area of loss can be tolerated if other areas have correspondingly higher efficiencies. We have restricted our consideration to photon loss which has enabled us to describe a quite complete error correction protocol for general quantum computation with a high loss tolerant threshold. However, neglecting other noise sources is rather unrealistic. In future work we plan to address more general error correction codes based on optical parity states.

Acknowledgments

This work was supported by the Australian Research Council, Queensland State Government, and DTO-funded U.S. Army Research Office Contract No. W911NF-05-0397.

-
- [1] E. Knill, R. Laflamme, and G. Milburn, *Nature* **409**, 46 (2001).
- [2] M. A. Nielsen and I. L. Chuang, *Quantum Computation and Quantum Information* (Cambridge University Press, Cambridge, 2000).
- [3] T. B. Pittman, M. J. Fitch, B. C. Jacobs, and J. D. Franson, *Phys. Rev. A* p. 032316 (2003).
- [4] J. L. O'Brien, G. J. Pryde, A. G. White, T. C. Ralph, and D. Branning, *Nature* p. 264 (2003).
- [5] S. Gasparoni, J. W. Pan, P. Walther, T. Rudolph, and A. Zeilinger, *Phys. Rev. Lett.* p. 020504 (2004).
- [6] M. A. Nielsen, *Optical quantum computation using cluster states* (2004), quant-ph/0402005.
- [7] R. Raussendorf and H. J. Briegel, *Phys. Rev. Lett.* **86**, 5188 (2001).
- [8] D. E. Browne and T. Rudolph, *Phys. Rev. Lett.* **95**, 010501 (2005).
- [9] M. A. Nielsen and C. M. Dawson, *Phys. Rev. A* **71**, 042323 (2005).
- [10] C. M. Dawson, H. L. Haselgrove, and M. A. Nielsen, *Phys. Rev. A* **73**, 052306 (2006).
- [11] P. Kok, W. J. Munro, K. Nemoto, T. C. Ralph, J. P. Dowling, and G. J. Milburn, *Rev. Mod. Phys.* **73**, 052306 (2006).
- [12] A. J. F. Hayes, A. Gilchrist, C. R. Myers, and T. C. Ralph, *J. Opt. B* **6**, 533 (2004).
- [13] T. C. Ralph, A. J. F. Hayes, and A. Gilchrist, *Phys. Rev. Lett.* **95**, 100501 (2005).
- [14] P. P. Rohde, T. C. Ralph, and W. J. Munro, *Phys. Rev. A* **75**, 010302 (2007).
- [15] E. Knill, R. Laflamme, and G. Milburn, *Thresholds for linear optics quantum computation* (2000), quant-ph/0006120.
- [16] H. Weinfurter, *Europhysics Lett.* **25**, 559 (1994).
- [17] S. L. Braunstein and A. Mann, *Phys. Rev. A* **51**, 1727 (1995).
- [18] A. Gilchrist, A. J. F. Hayes, and T. C. Ralph, *Phys. Rev. A* **75**, 052328 (2007).