

Uniform Estimates for the Flow of a Viscous Incompressible Fluid down an Inclined Plane in the Thin Film Regime

Dedicated to Professor Shuichi Kawashima on the occasion of his 60th birthday

Hiroki Ueno, Akinori Shiraishi, and Tatsuo Iguchi

Abstract

We consider a two-dimensional motion of a thin film flowing down an inclined plane under the influence of the gravity and the surface tension. In order to investigate the stability of such flow, it is hard to treat the Navier–Stokes equations directly, so that a thin film approximation is often used. It is an approximation obtained by the perturbation expansion with respect to the aspect ratio δ of the film under the thin film regime $\delta \ll 1$. Our purpose is to give a mathematically rigorous justification of the thin film approximation by establishing an error estimate between the solution of the Navier–Stokes equations and those of approximate equations. To this end, in this paper we derive a uniform estimate for the solution of the Navier–Stokes equations with respect to δ under appropriate assumptions.

1 Introduction

In this paper, we consider a two-dimensional motion of a liquid film of a viscous and incompressible fluid flowing down an inclined plane under the influence of the gravity and the surface tension on the interface. The motion can be mathematically formulated as a free boundary problem for the incompressible Navier–Stokes equations. We assume that the domain $\Omega(t)$ occupied by the liquid at time $t \geq 0$, the liquid surface $\Gamma(t)$, and the rigid plane Σ are of the forms

$$\begin{cases} \Omega(t) = \{(x, y) \in \mathbb{R}^2 \mid 0 < y < h_0 + \eta(x, t)\}, \\ \Gamma(t) = \{(x, y) \in \mathbb{R}^2 \mid y = h_0 + \eta(x, t)\}, \\ \Sigma = \{(x, y) \in \mathbb{R}^2 \mid y = 0\}, \end{cases}$$

where h_0 is the mean thickness of the liquid film and $\eta(x, t)$ is the amplitude of the liquid surface. Here we choose a coordinate system (x, y) so that x axis is down and y axis is normal to the plane. The motion of the liquid is described by the velocity $\mathbf{u} = (u, v)^T$ and the pressure p

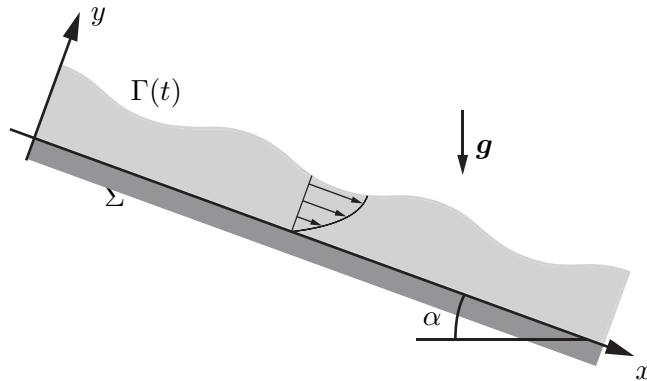

Figure 1: Sketch of a thin liquid film flowing down an inclined plane

satisfying the Navier–Stokes equations

$$(1.1) \quad \begin{cases} \rho(\mathbf{u}_t + (\mathbf{u} \cdot \nabla)\mathbf{u}) = \nabla \cdot \mathbf{P} + \rho g(\sin \alpha, -\cos \alpha)^T & \text{in } \Omega(t), t > 0, \\ \nabla \cdot \mathbf{u} = 0 & \text{in } \Omega(t), t > 0, \end{cases}$$

where $\mathbf{P} = -p\mathbf{I} + 2\mu\mathbf{D}$ is the stress tensor, $\mathbf{D} = \frac{1}{2}(D\mathbf{u} + (D\mathbf{u})^T)$ is the deformation tensor, \mathbf{I} is the unit matrix, ρ is a constant density of the liquid, g is the acceleration of the gravity, α is the angle of inclination, and μ is the shear viscosity coefficient. The dynamical and kinematic conditions on the liquid surface are

$$(1.2) \quad \begin{cases} \mathbf{P}\mathbf{n} = -p_0\mathbf{n} + \sigma H\mathbf{n} & \text{on } \Gamma(t), t > 0, \\ \eta_t + u\eta_x - v = 0 & \text{on } \Gamma(t), t > 0, \end{cases}$$

where \mathbf{n} is the unit outward normal vector to the liquid surface, that is, $\mathbf{n} = \frac{1}{\sqrt{1+\eta_x}}(-\eta_x, 1)^T$, p_0 is a constant atmospheric pressure, σ is the surface tension coefficient, and H is the twice mean curvature of the liquid surface, that is, $H = \left(\frac{\eta_x}{\sqrt{1+\eta_x^2}}\right)_x$. The boundary condition on the rigid plane is the non-slip condition

$$(1.3) \quad \mathbf{u} = \mathbf{0} \quad \text{on } \Sigma, t > 0.$$

These equations have a laminar steady solution of the form

$$(1.4) \quad \eta = 0, \quad u = (\rho g \sin \alpha / 2\mu)(2h_0 y - y^2), \quad v = 0, \quad p = p_0 - \rho g \cos \alpha (y - h_0),$$

which is called the Nusselt flat film solution. Throughout this paper, we assume that the flow is downward l_0 -periodic or approaches asymptotically this flat film solution at spacially infinity.

Concerning the instability of this laminar flow, there are vast research literatures from the physical and engineering point of view. The first investigation of the wave motion of thin film including the effect of the surface tension was provided by Kapitza [11]. In Particular, he considered the case where the liquid film flows down a vertical wall, that is, the case $\alpha = \frac{\pi}{2}$. Yih [23] first formulated the linear stability problem of the laminar flow of the liquid film flowing down an inclined plane as an eigenvalue problem for the complex phase velocity, more specifically, the Orr-Sommerfeld problem although he neglected the effect of the surface tension. Benjamin [3] took into account the effect of the surface tension and showed that the critical Reynolds number is given by $R_c = \frac{5}{4} \frac{1}{\tan \alpha}$ by expanding the normal mode solution in powers of y . (In his original paper, the critical Reynolds number was given by $R_c = \frac{5}{6} \frac{1}{\tan \alpha}$. This difference comes from the definition of the Reynolds number, that is, Benjamin used the average speed of the Nusselt flat film solution, whereas we use the speed of the solution on the liquid surface as in Benney [4].) Later, Yih [24] showed the same condition by expanding the normal mode solution in powers of the aspect ratio of the film which will be denoted by δ in this article. An approach taking into account the nonlinearity was first given by Mei [13] and Benney [4]. While Mei considered the gravity waves, Benney considered the capillary-gravity waves and he recovered Benjamin's and Yih's linear stability theories.

Using the mean thickness of the liquid h_0 , the characteristic scale of the streamwise direction l_0 , and the typical amplitude of the liquid surface a_0 , Benney introduced two non-dimensional parameters δ and ε defined by

$$\delta = \frac{h_0}{l_0}, \quad \varepsilon = \frac{a_0}{h_0},$$

respectively. We note that we do not determine a characteristic scale l_0 in x a priori because l_0 is a typical wavelength of a nontrivial wave pattern which arises as a consequence of a destabilization

and l_0 itself is an object of scientific interest. While theoretically the destabilization appears as a long wave instability in the case $\delta \rightarrow 0$, which corresponds to the case $l_0 \rightarrow \infty$, experimentally l_0 is often determined by observing waves generated by an external vibrator. Benney derived the following single nonlinear evolution equation

$$(1.5) \quad \begin{aligned} \eta_t = & A(1 + \varepsilon\eta)\eta_x + \delta(B(1 + \varepsilon\eta)\eta_{xx} + \varepsilon C(1 + \varepsilon\eta)\eta_x^2) \\ & + \delta^2(D(1 + \varepsilon\eta)\eta_{xxx} + \varepsilon E(1 + \varepsilon\eta)\eta_x\eta_{xx} + \varepsilon^2 F(1 + \varepsilon\eta)\eta_x^3) \\ & + \delta^3(G(1 + \varepsilon\eta)\eta_{xxxx} + \varepsilon H(1 + \varepsilon\eta)\eta_x\eta_{xxx} + \varepsilon I(1 + \varepsilon\eta)\eta_{xx}^2 \\ & + \varepsilon^2 J(1 + \varepsilon\eta)\eta_x^2\eta_{xx} + \varepsilon^3 K(1 + \varepsilon\eta)\eta_x^4) + O(\delta^4) \end{aligned}$$

with polynomials A, B, \dots, K in $1 + \varepsilon\eta$ by the method of a perturbation expansion of the solution (u, v, p) with respect to δ under the thin film regime $\delta \ll 1$.

Thereafter, several authors have followed the Benney's approach. We note that if the Weber number W satisfies the condition $W = O(1)$, the effect of the surface tension does not appear until the term of $O(\delta^3)$ in (1.5). Since Benney considered the case $W = O(1)$ and calculated the terms up to $O(\delta^2)$, the effect of the surface tension was omitted in his stability analysis. Consequently, his results showed that linearly unstable waves grow more rapidly in the nonlinear range. Nakaya [14] computed the terms up to $O(\delta^3)$ and showed that the surface tension has a stabilization effect in the development of the monochromatic waves. On the other hand, Gjevik [8] incorporated the effect of the surface tension into the equation by assuming the condition $W = O(\delta^{-2})$ and investigated the growth of an initially unstable periodic surface perturbation and its nonlinear interaction with the higher harmonics. Their results imply that the surface tension plays an important role in investigating the stability of surface waves, which have already been pointed out by Kapitza [11]. We remark that the condition $W = O(\delta^{-2})$ holds for many kinds of fluid such as water and alcohol at normal temperature. Moreover, several authors extended the Benney's results to the three-dimensional case. Roskes [17] calculated the terms up to $O(\delta^2)$ and investigated the interactions between two-dimensional and three-dimensional weakly nonlinear waves on the liquid film under the condition $W = O(1)$, which implies that he did not consider the effect of the surface tension. Atherton and Homsy [1] and Lin and Krishna [12] calculated the terms up to $O(\delta)$ and $O(\delta^2)$, respectively, under the condition $W = O(\delta^{-2})$, namely, they took the effect of the surface tension in the equation in three-dimensional case. Furthermore, while they considered the case where $R = O(1)$, Topper and Kawahara [20] derived approximate equations under the conditions $W = O(\delta^{-2})$ and $R = O(\delta)$. More details or a list of useful references about the thin film approximation can be found in [6, 7, 10, 16].

Many approximate equations are obtained from (1.5). For example, by neglecting the terms of $O(\delta^2 + \varepsilon^2)$, we obtain the Burgers equation

$$(1.6) \quad \eta_t = -2\eta_x - 4\varepsilon\eta\eta_x + \delta B(1)\eta_{xx}$$

with $B(1) = \frac{8}{15}(\frac{5}{4}\frac{1}{\tan\alpha} - R)$, from which we can recover the Benjamin's critical Reynolds number $R_c = \frac{5}{4}\frac{1}{\tan\alpha}$. By neglecting the terms of $O(\delta^3 + \varepsilon\delta + \varepsilon^2)$, we obtain the KdV–Burgers equation

$$(1.7) \quad \eta_t = -2\eta_x - 4\varepsilon\eta\eta_x + \delta B(1)\eta_{xx} + \delta^2 D(1)\eta_{xxx},$$

which was named by Johnson [9]. Here, $D(1) = -2 - \frac{22}{63}R^2 + \frac{40}{63}\frac{R}{\tan\alpha}$. By neglecting the terms of $O(\delta^4 + \varepsilon\delta + \varepsilon^2)$ and assuming $R > R_c$, we obtain the so-called KdV–Kuramoto–Sivashinsky equation or Kawahara equation (see [20])

$$(1.8) \quad \eta_t = -2\eta_x - 4\varepsilon\eta\eta_x + \delta B(1)\eta_{xx} + \delta^2 D(1)\eta_{xxx} + \delta^3 G(1)\eta_{xxxx}$$

with $G(1) = -\frac{2}{3} \frac{W}{\sin \alpha} - \frac{157}{56} R - \frac{8}{45} \frac{R}{\tan^2 \alpha} + \frac{138904}{155925} \frac{R^2}{\tan \alpha} - \frac{1213952}{2027025} R^3$. Note that the effect of the surface tension, namely, the Weber number W , first appears in the coefficient of the fourth order derivative term in the case $W = O(1)$. Moreover, by assuming $\varepsilon = 1$, that is, the strongly nonlinear case and $W = \delta^2 \widetilde{W}$ and neglecting the terms of $O(\delta^2)$, we obtain the so-called Benney equation (see [8])

$$(1.9) \quad \eta_t = \left[-\frac{2}{3}(1 + \eta)^3 + \delta \left\{ \frac{2}{3 \tan \alpha} (1 + \eta)^3 \eta_x - \frac{8R}{15} (1 + \eta)^6 \eta_x - \frac{2\widetilde{W}}{3 \sin \alpha} (1 + \eta)^3 \eta_{xxx} \right\} \right]_x.$$

Now, our purpose is to give a mathematically rigorous justification of these thin film approximations by establishing the error estimate between the solution of the Navier–Stokes equations (1.1)–(1.3) and those of approximate equations (1.6)–(1.9). More specifically, we will estimate a norm of a difference between the solution η^δ of Navier–Stokes equations and the solution η^{app} of approximate equations (1.6)–(1.9) and show that the norm goes to 0 as $\delta \rightarrow 0$. In order to carry out the justification, the most difficult task is to derive a uniform estimate for the solution of the Navier–Stokes equations with respect to δ in the thin film regime $\delta \ll 1$. In this paper, we will focus on deriving a uniform estimate of the solution with respect to δ when the Reynolds number, the angle of inclination, and the initial data are sufficiently small under the conditions $O(1) \leq W \leq O(\delta^{-2})$, $R = O(1)$, $\alpha = O(1)$, and $x \in \mathbb{T}$ or \mathbb{R} . In [22], we will give the mathematically rigorous justification of the thin film approximations. We remark that Bresch and Noble [5] have already derived a uniform estimate of the solution with respect to δ by assuming $W = O(\delta^{-2})$, $R = O(\delta)$, $\alpha = O(\sqrt{\delta})$, $x \in \mathbb{T}$, and that initial data are sufficiently small. Their assumptions on R and α are too restrictive when we consider the asymptotic behavior of the solution as $\delta \rightarrow 0$. Moreover, they assumed $\varepsilon = \delta$ and excluded the case of $\varepsilon = 1$, so that their uniform estimate cannot be applied to the justification for the Benney equation. Therefore, our results are not included in their works.

Concerning a mathematical analysis of the problem, Teramoto [18] showed that the initial value problem to the Navier–Stokes equations (1.1)–(1.3) has a unique solution globally in time under the assumptions that the Reynolds number and the initial data are sufficiently small. Nishida, Teramoto, and Win [15] showed the exponential stability of the Nusselt flat film solution under the assumptions that the angle of inclination is sufficiently small and the flow is downward periodic in addition to the assumptions in [18]. Furthermore, Uecker [21] studied the asymptotic behavior for $t \rightarrow \infty$ of the solution in the case of $x \in \mathbb{R}$ and showed that the perturbations of the Nusselt flat film solution decay like the self-similar solution of the Burgers equation under the assumptions that the initial data are sufficiently small and $R < R_c$. However, they did not consider the δ scaling because they non-dimensionalized x and y components by using the same unit length h_0 .

The plan of this paper is as follows. In Section 2, we rewrite the problem in a non-dimensional form and transform the problem in a time dependent domain to a problem in a time independent domain by using an appropriate diffeomorphism. Then, we give our main theorem in this paper and we remark that an outline of the proof is same as [15]. In Section 3, we derive energy estimates to the transformed equations. Only by following [15], we cannot obtain a uniform estimate in δ because we cannot control lower order terms just by using energies derived in [15]. Hence, we introduce an essentially new energy function in order to control lower order terms which is one of difficulties to obtain a uniform boundedness of the solution in δ . Therefore, Section 3 is a key section in this paper. In Section 4, we give estimates for the pressure. In order to obtain a uniform estimate in δ , we need to carefully estimate the pressure, while in [15]

there was no need to use such a estimate. In Section 5, we estimate carefully nonlinear terms appeared in the right-hand side of the energy inequality so that we can get a uniform estimate in δ . Finally, combining the estimates obtained in the last three sections, we derive a uniform estimate of the solution in Section 6.

Notation. We put $\Omega = \mathbb{G} \times (0, 1)$ and $\Gamma = \mathbb{G} \times \{y = 1\}$, where \mathbb{G} is the flat torus $\mathbb{T} = \mathbb{R}/\mathbb{Z}$ or \mathbb{R} . For a Banach space X , we denote by $\|\cdot\|_X$ the norms in X . For $1 \leq p \leq \infty$, we put $\|u\|_{L^p} = \|u\|_{L^p(\Omega)}$, $\|u\| = \|u\|_{L^2}$, $|u|_{L^p} = \|u(\cdot, 1)\|_{L^p(\mathbb{G})}$, and $|u|_0 = |u|_{L^2}$. We denote by $(\cdot, \cdot)_\Omega$ and $(\cdot, \cdot)_\Gamma$ the inner products of $L^2(\Omega)$ and $L^2(\Gamma)$, respectively. For $s \geq 0$, we denote by $H^s(\Omega)$ and $H^s(\Gamma)$ the L^2 Sobolev spaces of order s on Ω and Γ , respectively. The norms of these spaces are denoted by $\|\cdot\|_s$ and $|\cdot|_s$. For a function $u = u(x, y)$ on Ω , a Fourier multiplier $P(D_x)$ ($D_x = -i\partial_x$) is defined by

$$(P(D_x)u)(x, y) = \begin{cases} \sum_{n \in \mathbb{Z}} P(n) \hat{u}_n(y) e^{2\pi i n x} & \text{in the case } \mathbb{G} = \mathbb{T}, \\ \int_{\mathbb{R}} P(\xi) \hat{u}(\xi, y) e^{2\pi i \xi x} d\xi & \text{in the case } \mathbb{G} = \mathbb{R}, \end{cases}$$

where $\hat{u}_n(y) = \int_0^1 u(x, y) e^{-2\pi i n x} dx$ is the Fourier coefficient and $\hat{u}(\xi, y) = \int_{\mathbb{R}} u(x, y) e^{-2\pi i \xi x} dx$ is the Fourier transform in x . We put $\nabla_\delta = (\delta\partial_x, \partial_y)^\top$, $\Delta_\delta = \nabla_\delta \cdot \nabla_\delta$, and $D_\delta^k f = \{(\delta\partial_x)^i \partial_y^j f \mid i+j = k\}$. For operators A and B , we denote by $[A, B] = AB - BA$ the commutator. We put

$$\partial_y^{-1} f(x, y) = - \int_y^1 f(x, z) dz.$$

$f \lesssim g$ means that there exists a non-essential positive constant C such that $f \leq Cg$ holds.

2 Reformulation of the problem and main result

We first rewrite (1.1)–(1.3) in a non-dimensional form. We will consider fluctuations on the stationary laminar flow given by (1.4), so that we rescale the independent and dependent variables by

$$\begin{cases} x = l_0 x', & y = h_0 y', & t = t_0 t', \\ \eta = a_0 \eta', & u = U_0(\bar{u}' + \varepsilon u'), & v = \varepsilon V_0 v', & p = p_0 + \varepsilon P_0 p', \end{cases}$$

where $U_0 = \rho g h_0^2 \sin \alpha / 2\mu$, $V_0 = (h_0/l_0)U_0$, $t_0 = l_0/U_0$, $\bar{u}' = 2y' - y'^2$, and $P_0 = \rho g h_0 \sin \alpha$. Putting these into (1.1)–(1.3) and dropping the prime sign in the notation, we obtain

$$(2.1) \quad \begin{cases} \delta \mathbf{u}_t^\delta + ((\mathbf{U} + \varepsilon \mathbf{u}^\delta) \cdot \nabla_\delta) \mathbf{u}^\delta + (\mathbf{u}^\delta \cdot \nabla_\delta) \mathbf{U} + \frac{2}{\mathbf{R}} \nabla_\delta p - \frac{1}{\mathbf{R}} \Delta_\delta \mathbf{u}^\delta = \mathbf{0} & \text{in } \Omega_\varepsilon(t), t > 0, \\ \nabla_\delta \cdot \mathbf{u}^\delta = 0 & \text{in } \Omega_\varepsilon(t), t > 0, \end{cases}$$

$$(2.2) \quad \begin{cases} (\mathbf{D}_\delta(\varepsilon \mathbf{u}^\delta + \mathbf{U}) - \varepsilon p \mathbf{I}) \mathbf{n}^\delta \\ = \left(-\frac{1}{\tan \alpha} \varepsilon \eta + \frac{\delta^2 \mathbf{W}}{\sin \alpha} \frac{\varepsilon \eta_{xx}}{(1 + (\varepsilon \delta \eta_x)^2)^{\frac{3}{2}}} \right) \mathbf{n}^\delta & \text{on } \Gamma_\varepsilon(t), t > 0, \\ \eta_t + (1 - (\varepsilon \eta)^2 + \varepsilon u) \eta_x - v = 0 & \text{on } \Gamma_\varepsilon(t), t > 0, \end{cases}$$

$$(2.3) \quad \mathbf{u}^\delta = \mathbf{0} \quad \text{on } \Sigma, t > 0,$$

where $\mathbf{u}^\delta = (u, \delta v)^\top$, $\mathbf{U} = (\bar{u}, 0)^\top$, $\bar{u} = 2y - y^2$, $\mathbf{D}_\delta \mathbf{f} = \frac{1}{2} \{ \nabla_\delta(\mathbf{f}^\top) + (\nabla_\delta(\mathbf{f}^\top))^\top \}$, $\mathbf{n}^\delta = (-\varepsilon \delta \eta_x, 1)^\top$, $\mathbf{R} = \rho U_0 h_0 / \mu$ is the Reynolds number, and $\mathbf{W} = \sigma / \rho g h_0^2$ is the Weber number. In this scaling, the liquid domain $\Omega_\varepsilon(t)$ and the liquid surface $\Gamma_\varepsilon(t)$ are of the forms

$$\begin{cases} \Omega_\varepsilon(t) = \{(x, y) \in \mathbb{R}^2 \mid 0 < y < 1 + \varepsilon \eta(x, t)\}, \\ \Gamma_\varepsilon(t) = \{(x, y) \in \mathbb{R}^2 \mid y = 1 + \varepsilon \eta(x, t)\}. \end{cases}$$

Next, we transform the problem in the moving domain $\Omega_\varepsilon(t)$ to a problem in the fixed domain Ω by using an appropriate diffeomorphism $\Phi : \Omega \rightarrow \Omega_\varepsilon(t)$ defined by

$$(2.4) \quad \Phi(x, y, t) = (x, y(1 + \varepsilon \tilde{\eta}(x, y, t))),$$

where $\tilde{\eta}$ is an extension of η to Ω . We need to choose the extension $\tilde{\eta}$ carefully and in this paper we adopt the following extension. For $\phi \in H^s(\Gamma)$, we define its extension $\tilde{\phi}$ to Ω by

$$(2.5) \quad \tilde{\phi}(x, y) = \begin{cases} \sum_{n \in \mathbb{Z}} \frac{\hat{\phi}_n}{1 + (\delta n(1 - y)y)^4} e^{2\pi i n x} & \text{in the case } \mathbb{G} = \mathbb{T}, \\ \int_{\mathbb{R}} \frac{\hat{\phi}(\xi)}{1 + (\delta \xi(1 - y)y)^4} e^{2\pi i \xi x} d\xi & \text{in the case } \mathbb{G} = \mathbb{R}. \end{cases}$$

By the definition, it is easy to see that

$$(2.6) \quad \partial_y^j \tilde{\phi}(x, 1) = \partial_y^j \tilde{\phi}(x, 0) = 0 \quad \text{for } 1 \leq j \leq 3.$$

As usual, this extension operator has a regularizing effect so that $\tilde{\phi} \in H^{s+\frac{1}{2}}(\Omega)$. However, if we use such a regularizing property, then we need to pay the cost of a power of δ . Moreover, in this extension, ∂_y corresponds to $\delta \partial_x$. More precisely, we have the following lemma, whose proof is quite standard, so we omit it.

Lemma 2.1. *Let i and j be non-negative integers such that $j \leq 4$. Then, for the extension (2.5) we have*

$$(2.7) \quad \|\partial_x^i \partial_y^j \tilde{\phi}\| \lesssim \delta^j |\partial_x^{i+j} \phi|_0,$$

$$(2.8) \quad \|\partial_x^i \partial_y^j \tilde{\phi}\|_{L^\infty} \lesssim \delta^j |\partial_x^{i+j} \phi|_1.$$

If, in addition, $i + j \geq 1$, then

$$(2.9) \quad \|\partial_x^i \partial_y^j \tilde{\phi}\| \lesssim \delta^{j-\frac{1}{2}} \|D_x\|^{i+j-\frac{1}{2}} \phi|_0.$$

The solenoidal condition on the velocity field is destroyed in general by the transformation. To keep the condition, following Beale [2], we also change the dependent variables and introduce new unknown functions (u', v', p') defined in Ω by

$$u' = J(u \circ \Phi), \quad v' = v \circ \Phi - y \varepsilon \tilde{\eta}_x(u \circ \Phi), \quad p' = p \circ \Phi,$$

where $J = 1 + \varepsilon(y \tilde{\eta})_y$ is the Jacobian of the diffeomorphism Φ . Putting $a_1 = -y J^{-1} \varepsilon \delta \tilde{\eta}_x$, $b_1 = J^{-1} - 1$, and

$$A_1 = \begin{pmatrix} 1 + b_1 & 0 \\ -a_1 & 1 \end{pmatrix} = N_1 + I, \quad \mathbf{u}'^\delta = \begin{pmatrix} u' \\ \delta v' \end{pmatrix},$$

we have

$$(2.10) \quad \mathbf{u}^\delta \circ \Phi = A_1 \mathbf{u}'^\delta.$$

Here N_1 is the nonlinear part of A_1 . We note that b_1 is the term which is hard to handle because it contains the term without δ in the coefficient. Then, the second equation in (2.2) is transformed to

$$(2.11) \quad \eta_t + \eta_x - v' = h_3,$$

where $h_3 = \varepsilon^2 \eta^2 \eta_x$. We easily obtain that

$$(2.12) \quad \begin{cases} (\nabla_\delta \phi) \circ \Phi = A_2 \nabla_\delta (\phi \circ \Phi), \\ (\Delta_\delta \phi) \circ \Phi = \delta^2 (\phi \circ \Phi)_{xx} + (1 + b_2) (\phi \circ \Phi)_{yy} + P_\delta(\tilde{\eta}, D) (\phi \circ \Phi), \end{cases}$$

$$(2.14) \quad \begin{cases} \delta(\phi_t \circ \Phi) = \delta(\phi \circ \Phi)_t - y J^{-1} \varepsilon \delta \tilde{\eta}_t (\phi \circ \Phi)_y, \end{cases}$$

where

$$A_2 = \begin{pmatrix} 1 & a_1 \\ 0 & 1 + b_1 \end{pmatrix} = N_2 + I,$$

N_2 is the nonlinear part of A_2 , $b_2 = a_1^2 + 2b_1 + b_1^2$, and $P_\delta(\tilde{\eta}, D)$ is a second order differential operator defined by $P_\delta(\tilde{\eta}, D)f = 2\delta a_1 f_{xy} + \{\delta a_{1x} + a_1 a_{1y} + (1 + b_1) b_{1y}\} f_y$.

We proceed to transform the equations. We begin to transform the equations in (2.1). By (2.10) and (2.14), we obtain

$$(2.15) \quad \delta \mathbf{u}_t^\delta \circ \Phi = \delta A_1 \mathbf{u}_t'^\delta + \mathbf{f}_1,$$

where

$$\mathbf{f}_1 = \delta A_{1t} \mathbf{u}'^\delta - y J^{-1} \varepsilon \delta \tilde{\eta}_t (A_1 \mathbf{u}'^\delta)_y.$$

By (2.10) and (2.12), we obtain

$$(2.16) \quad \{((\mathbf{U} + \varepsilon \mathbf{u}^\delta) \cdot \nabla_\delta) \mathbf{u}^\delta + (\mathbf{u}^\delta \cdot \nabla_\delta) \mathbf{U}\} \circ \Phi = (\mathbf{U} \cdot \nabla_\delta) \mathbf{u}'^\delta + (\mathbf{u}'^\delta \cdot \nabla_\delta) \mathbf{U} + \mathbf{f}_2,$$

where

$$\begin{aligned} \mathbf{f}_2 &= (\mathbf{U} \cdot \nabla_\delta) N_1 \mathbf{u}'^\delta + (\mathbf{U} \cdot N_2 \nabla_\delta) A_1 \mathbf{u}'^\delta + ((\mathbf{V} + \varepsilon A_1 \mathbf{u}'^\delta) \cdot A_2 \nabla_\delta) A_1 \mathbf{u}'^\delta \\ &\quad + (\mathbf{u}'^\delta \cdot N_2 \nabla_\delta) \mathbf{U} + ((N_1 \mathbf{u}'^\delta) \cdot (A_2 \nabla_\delta)) \mathbf{U} + ((A_1 \mathbf{u}'^\delta) \cdot (A_2 \nabla_\delta)) \mathbf{V}, \\ \mathbf{V} &= \begin{pmatrix} 2\varepsilon y \tilde{\eta} - 2\varepsilon y^2 \tilde{\eta} - (\varepsilon y \tilde{\eta})^2 \\ 0 \end{pmatrix}. \end{aligned}$$

By (2.12), we have

$$(2.17) \quad (\nabla_\delta p) \circ \Phi = A_2 \nabla_\delta p'.$$

By (2.10) and (2.13), we obtain

$$(2.18) \quad (\Delta_\delta \mathbf{u}^\delta) \circ \Phi = A_1 (\delta^2 \mathbf{u}'^\delta_{xx} + (I + A_3) \mathbf{u}'^\delta_{yy}) + \mathbf{f}_3,$$

where

$$\begin{aligned} A_3 &= \begin{pmatrix} b_2 & 0 \\ 0 & 0 \end{pmatrix}, \\ \mathbf{f}_3 &= [\delta^2 \partial_x^2, A_1] \mathbf{u}'^\delta + (1 + b_2) [\partial_y^2, A_1] \mathbf{u}'^\delta + P_\delta(\tilde{\eta}, D) (A_1 \mathbf{u}'^\delta) + A_1 \begin{pmatrix} 0 \\ \delta b_2 v'_{yy} \end{pmatrix}. \end{aligned}$$

Thus combining (2.15)–(2.18), we transform the first equation in (2.1) to

$$(2.19) \quad \delta \mathbf{u}'_t{}^\delta + (\mathbf{U} \cdot \nabla_\delta) \mathbf{u}'^\delta + (\mathbf{u}'^\delta \cdot \nabla_\delta) \mathbf{U} + \frac{2}{\mathbf{R}}(I + A_4) \nabla_\delta p' - \frac{1}{\mathbf{R}} \left(\delta^2 \mathbf{u}'_{xx}{}^\delta + (I + A_3) \mathbf{u}'_{yy}{}^\delta \right) = \mathbf{f},$$

where

$$(2.20) \quad \mathbf{f} = -N \{ (\mathbf{U} \cdot \nabla_\delta) \mathbf{u}'^\delta + (\mathbf{u}'^\delta \cdot \nabla_\delta) \mathbf{U} \} + A_1^{-1} \left(-\mathbf{f}_1 - \mathbf{f}_2 + \frac{1}{\mathbf{R}} \mathbf{f}_3 \right),$$

$$(2.21) \quad A_4 = A_1^{-1} A_2 - I = \begin{pmatrix} (y\varepsilon\tilde{\eta})_y & -y\varepsilon\delta\tilde{\eta}_x \\ -y\varepsilon\delta\tilde{\eta}_x & J^{-1}((y\varepsilon\delta\tilde{\eta}_x)^2 - (y\varepsilon\tilde{\eta})_y) \end{pmatrix},$$

and N is the nonlinear part of A_1^{-1} . We remark that \mathbf{f} is a collection of nonlinear terms, which does not contain $\mathbf{u}'_t{}^\delta$, u'_y , $\nabla_\delta p'$, nor any function of $\tilde{\eta}$ only.

Next, we transform the boundary conditions. By (2.10) and (2.12), we see that

$$\{ (\mathbf{D}_\delta(\varepsilon \mathbf{u}^\delta + \mathbf{U}) - \varepsilon p I) \mathbf{n}^\delta \} \circ \Phi = \begin{pmatrix} \frac{1}{2} \varepsilon (\delta^2 v'_x + u'_y - 2\eta) \\ \varepsilon \delta v'_y \end{pmatrix} - \varepsilon p' \mathbf{n}^\delta + \mathbf{h} \quad \text{on } \Gamma,$$

where

$$\begin{aligned} \mathbf{h} = & - \begin{pmatrix} \varepsilon^2 \delta^2 \eta_x u'_x \\ \frac{1}{2} \varepsilon^2 \delta \eta_x (\delta^2 v'_x + u'_y - 2\eta) \end{pmatrix} \\ & + \frac{\varepsilon}{2} \{ \nabla_\delta (N_1 \mathbf{u}'^\delta)^\mathbf{T} + (\nabla_\delta (N_1 \mathbf{u}'^\delta)^\mathbf{T})^\mathbf{T} + N_2 \nabla_\delta (A_1 \mathbf{u}'^\delta)^\mathbf{T} + (N_2 \nabla_\delta (A_1 \mathbf{u}'^\delta)^\mathbf{T})^\mathbf{T} \} \mathbf{n}^\delta. \end{aligned}$$

Taking the inner product of a tangential vector $\mathbf{t}^\delta = (1, \varepsilon \delta \eta_x)^\mathbf{T}$ with the first equation in (2.2), we obtain

$$(2.22) \quad \delta^2 v'_x + u'_y - 2\eta = h_4 \quad \text{on } \Gamma,$$

where

$$h_4 = -\frac{2}{\varepsilon} (\varepsilon^2 \delta^2 \eta_x v'_y + \mathbf{h} \cdot \mathbf{t}^\delta).$$

On the other hand, taking the inner product of a normal vector \mathbf{n}^δ with the first equation in (2.2), we obtain

$$(2.23) \quad p' - \delta v'_y - \frac{1}{\tan \alpha} \eta + \frac{\delta^2 \mathbf{W}}{\sin \alpha} \eta_{xx} = h_2 \quad \text{on } \Gamma,$$

where

$$(2.24) \quad \begin{aligned} h_2 = & \frac{1}{\varepsilon} \left\{ -\frac{(\varepsilon \delta \eta_x)^2}{1 + (\varepsilon \delta \eta_x)^2} \varepsilon \delta v'_y + \frac{1}{1 + (\varepsilon \delta \eta_x)^2} \left(-\frac{1}{2} \varepsilon^2 \delta \eta_x (\delta^2 v'_x + u'_y - 2\eta) + \mathbf{h} \cdot \mathbf{n}^\delta \right) \right\} \\ & + \frac{\delta^2 \mathbf{W}}{\sin \alpha} \left(1 - \frac{1}{(1 + (\varepsilon \delta \eta_x)^2)^{\frac{3}{2}}} \right) \eta_{xx} \\ = & h_{2,1} + \delta^2 \mathbf{W} h_{2,2} \end{aligned}$$

and h_2 does not contain p' nor any function of η only. Note that the term $\delta^2 \mathbf{W} h_{2,2}$ is the only nonlinear term which contains \mathbf{W} . Here, by a straightforward calculation we see that

$$\mathbf{h} \cdot \mathbf{t}^\delta = \varepsilon (b_4 u'_y + h_5),$$

where

$$b_4 = -\frac{1}{2}(\varepsilon\delta\eta_x)^2 + \left\{ \begin{pmatrix} a_1(1+b_1) & \frac{1}{2}(-a_1^2 + b_1(2+b_1)) \\ \frac{1}{2}(-a_1^2 + b_1(2+b_1)) & -a_1(1+b_1) \end{pmatrix} \mathbf{n}^\delta \right\} \cdot \mathbf{t}^\delta,$$

$$h_5 = -\varepsilon\delta^2\eta_x u'_x - \frac{1}{2}(\varepsilon\delta\eta_x)^2(\delta^2 v'_x - 2\eta) + \left\{ \begin{pmatrix} \delta(b_1 u')_x & \frac{1}{2}\{\delta(-a_1 u')_x - a_1 a_{1y} u' + \delta a_1 v'_y\} \\ \frac{1}{2}\{\delta(-a_1 u')_x - a_1 a_{1y} u' + \delta a_1 v'_y\} & -a_{1y}(1+b_1)u' + \delta b_1 v'_y \end{pmatrix} \mathbf{n}^\delta \right\} \cdot \mathbf{t}^\delta,$$

and h_5 does not contain u'_y . Thus we can rewrite (2.22) as

$$(2.25) \quad \delta^2 v'_x + u'_y - (2 + b_3)\eta = h_1 \quad \text{on } \Gamma,$$

where

$$(2.26) \quad b_3 = -\frac{4b_4}{1 + 2b_4},$$

$$(2.27) \quad h_1 = \frac{2b_4}{1 + 2b_4}\delta^2 v'_x - \frac{2}{1 + 2b_4}(\varepsilon\delta^2\eta_x v'_y + h_5).$$

Note that h_1 does not contain u'_y , p' , nor any function of η only.

Summarizing (2.11), (2.19), (2.23), and (2.25) and dropping the prime sign in the notation, we have

$$(2.28) \quad \begin{cases} \delta \mathbf{u}_t^\delta + (\mathbf{U} \cdot \nabla_\delta) \mathbf{u}^\delta + (\mathbf{u}^\delta \cdot \nabla_\delta) \mathbf{U} \\ \quad + \frac{2}{\mathbf{R}}(I + A_4) \nabla_\delta p - \frac{1}{\mathbf{R}} \{ \delta^2 \mathbf{u}_{xx}^\delta + (I + A_3) \mathbf{u}_{yy}^\delta \} = \mathbf{f} & \text{in } \Omega, t > 0, \\ u_x + v_y = 0 & \text{in } \Omega, t > 0, \end{cases}$$

$$(2.29) \quad \begin{cases} \delta^2 v_x + u_y - (2 + b_3)\eta = h_1 & \text{on } \Gamma, t > 0, \\ p - \delta v_y - \frac{1}{\tan \alpha} \eta + \frac{\delta^2 \mathbf{W}}{\sin \alpha} \eta_{xx} = h_2 & \text{on } \Gamma, t > 0, \\ \eta_t + \eta_x - v = h_3 & \text{on } \Gamma, t > 0, \end{cases}$$

$$(2.30) \quad u = v = 0 \quad \text{on } \Sigma, t > 0.$$

In the following, we will consider the initial value problem to (2.28)–(2.30) under the initial conditions

$$(2.31) \quad \eta|_{t=0} = \eta_0 \quad \text{on } \Gamma, \quad (u, v)|_{t=0} = (u_0, v_0)^T \quad \text{in } \Omega.$$

Here we denote b_3 and h_1 determined from the initial data by $b_3^{(0)}$ and $h_1^{(0)}$, respectively.

Now, we are ready to state our main result in this paper.

Theorem 2.2. (*Uniform estimate*) *There exist small positive constants \mathbf{R}_0 and α_0 such that the following statement holds: Let m be an integer satisfying $m \geq 2$, $0 < \mathbf{R}_1 \leq \mathbf{R}_0$, $0 < \mathbf{W}_1 \leq \mathbf{W}_2$, and $0 < \alpha \leq \alpha_0$. There exist positive constants c_0 and T such that if the initial data (η_0, u_0, v_0) and the parameters $\delta, \varepsilon, \mathbf{R}$, and \mathbf{W} satisfy the compatibility conditions*

$$\begin{cases} u_{0x} + v_{0y} = 0 & \text{in } \Omega, \\ u_{0y} + \delta^2 v_{0x} - (2 + b_3^{(0)})\eta_0 = h_1^{(0)} & \text{on } \Gamma, \\ u_0 = v_0 = 0 & \text{on } \Sigma, \end{cases}$$

and

$$\begin{cases} |(1 + \delta|D_x|)^2\eta_0|_2 + \|(1 + |D_x|)^2(u_0, \delta v_0)^T\| + \|(1 + |D_x|)^2 D_\delta(u_0, \delta v_0)^T\| \\ \quad + \|(1 + |D_x|)^2 D_\delta^2(u_0, \delta v_0)^T\| + \delta^2 \mathbb{W} |(1 + \delta|D_x|)\eta_{0x}|_3 + \sqrt{\delta^2 \mathbb{W}} \|(1 + |D_x|)^2 \delta v_{0xy}\| \leq c_0, \\ |(1 + \delta|D_x|)^2\eta_0|_m + \|(1 + |D_x|)^m(u_0, \delta v_0)^T\| + \|(1 + |D_x|)^m D_\delta(u_0, \delta v_0)^T\| \\ \quad + \|(1 + |D_x|)^m D_\delta^2(u_0, \delta v_0)^T\| + \delta^2 \mathbb{W} |(1 + \delta|D_x|)\eta_{0x}|_{m+1} + \sqrt{\delta^2 \mathbb{W}} \|(1 + |D_x|)^m \delta v_{0xy}\| \leq M, \\ 0 < \delta, \varepsilon \leq 1, \quad \mathbf{R}_1 \leq \mathbf{R} \leq \mathbf{R}_0, \quad \mathbf{W}_1 \leq \mathbf{W} \leq \delta^{-2} \mathbf{W}_2, \end{cases}$$

then the initial value problem (2.28)–(2.31) has a unique solution (η, u, v, p) on the time interval $[0, T/\varepsilon]$ and the solution satisfies the estimate

$$\begin{aligned} & |(1 + \delta|D_x|)^2\eta(t)|_m^2 + \delta^2 |\eta_t(t)|_m^2 + \delta^2 \mathbb{W} \{ |(1 + \delta|D_x|)^2\eta_x(t)|_m^2 + \delta^2 |\eta_{tx}(t)|_m^2 \} \\ & + \|(1 + |D_x|)^m (1 + \delta|D_x|)^2 \mathbf{u}^\delta(t)\|^2 + \|(1 + |D_x|)^m \mathbf{u}_y^\delta(t)\|^2 + \delta^2 \|(1 + |D_x|)^m \mathbf{u}_t^\delta(t)\|^2 \\ & + \int_0^t \{ \delta |\eta_x(\tau)|_m^2 + \delta (1 + \delta|D_x|)^{\frac{5}{2}} \eta_t(\tau)|_m^2 \\ & \quad + (\delta^2 \mathbb{W}) \delta |\eta_{xx}(\tau)|_m^2 + (\delta^2 \mathbb{W})^2 \{ \delta |\eta_{xxx}(\tau)|_m^2 + \delta^2 |D_x|^{\frac{7}{2}} \eta(\tau)|_m^2 \} \\ & \quad + \delta \|(1 + |D_x|)^m \mathbf{u}_x^\delta(\tau)\|^2 + \delta \|(1 + |D_x|)^m (1 + \delta|D_x|) \nabla_\delta \mathbf{u}_x^\delta(\tau)\|^2 + \delta \|(1 + |D_x|)^m \nabla_\delta \mathbf{u}_t^\delta(\tau)\|^2 \\ & \quad + \delta^{-1} \|(1 + |D_x|)^m (1 + \delta|D_x|) \mathbf{u}_{yy}^\delta(\tau)\|^2 + \delta \|(1 + |D_x|)^m \partial_y^{-1} p_x(\tau)\|^2 \\ & \quad + \delta^{-1} \|(1 + |D_x|)^m (1 + \delta|D_x|) \nabla_\delta p(\tau)\|^2 + \delta \|(1 + |D_x|)^{m-1} \nabla_\delta p_t(\tau)\|^2 \} d\tau \leq C \end{aligned}$$

for $0 \leq t \leq T/\varepsilon$ with a constant $C = C(\mathbf{R}_1, \mathbf{W}_1, \mathbf{W}_2, \alpha, M)$ independent of $\delta, \varepsilon, \mathbf{R}$, and \mathbf{W} . Moreover, the following uniform estimate holds.

$$(2.32) \quad \begin{aligned} & |\eta(t)|_m + \|(1 + |D_x|)^{m-1} u(t)\|_1 + \|\partial_x^m u_y(t)\| \\ & + \|(1 + |D_x|)^{m-2} v(t)\|_1 + \|\partial_x^{m-1} v_{yy}(t)\| \leq C \end{aligned}$$

for $0 \leq t \leq T/\varepsilon$. If, in addition, $0 \leq \varepsilon \lesssim \delta$, then the solution can be extended for all $t \geq 0$ and the above estimates hold for $t \geq 0$.

Remark 2.1. In the case $\varepsilon \simeq 1$, this theorem gives a uniform boundedness of the solution only for a short time interval $[0, T]$. However, this is essential and we cannot extend this uniform estimate for all $t \geq 0$ in general, because by (1.5) we see that the limiting equation for η as $\delta \rightarrow 0$ becomes a nonlinear hyperbolic conservation law of the form

$$\eta_t + 2(1 + \varepsilon\eta)^2 \eta_x = 0,$$

whose solution will have a singularity in finite time in general.

Remark 2.2. In the case where $\mathbb{G} = \mathbb{T}, \varepsilon \lesssim \delta$, and $\int_0^1 \eta_0(x) dx = 0$, we also obtain the following exponential decay in time property of the solution.

$$(2.33) \quad \begin{aligned} & |(1 + \delta|D_x|)^2\eta(t)|_m^2 + \delta^2 |\eta_t(t)|_m^2 + \delta^2 \mathbb{W} \{ |(1 + \delta|D_x|)^2\eta_x(t)|_m^2 + \delta^2 |\eta_{tx}(t)|_m^2 \} \\ & + \|(1 + |D_x|)^m (1 + \delta|D_x|)^2 \mathbf{u}^\delta(t)\|^2 + \|(1 + |D_x|)^m \mathbf{u}_y^\delta(t)\|^2 + \delta^2 \|(1 + |D_x|)^m \mathbf{u}_t^\delta(t)\|^2 \leq C e^{-c\delta t}. \end{aligned}$$

Remark 2.3. In order to derive a uniform estimate in \mathbf{R} , the constant C in the above estimate is required to depend on a lower bound \mathbf{R}_1 of \mathbf{R} for a technical reason. However, for a justification of the thin film approximation this restriction matters little because we are interested in the case where \mathbf{R} is close enough to \mathbf{R}_c .

3 Energy estimates

We recall two fundamental inequalities which have a key role in this paper.

Lemma 3.1. (*Korn's inequality*) *There exists a constant K independent of δ such that for any $0 < \delta \leq 1$ and $\mathbf{u} = (u, v)^T$ satisfying*

$$\begin{cases} u_x + v_y = 0 & \text{in } \Omega, \\ u = v = 0 & \text{on } \Sigma, \end{cases}$$

we have

$$\iint_{\Omega} (\delta^2 u_x^2 + u_y^2 + \delta^4 v_x^2 + \delta^2 v_y^2) dx dy \leq K \iint_{\Omega} (2\delta^2 u_x^2 + (u_y + \delta^2 v_x)^2 + 2\delta^2 v_y^2) dx dy.$$

Remark 3.1. Teramoto and Tomoeda [19] proved that the best constant of K is 3. Note that in the case of $\delta = 1$, this inequality is well-known.

Lemma 3.2. (*Trace theorem*) *For $0 < \delta \leq 1$, we have*

$$|f|_0^2 + \delta \| |D_x|^{\frac{1}{2}} f |_0^2 \lesssim \|f\|^2 + \delta^2 \|f_x\|^2 + \|f_y\|^2.$$

Remark 3.2. This trace theorem is also well-known in the case of $\delta = 1$.

We omit the proofs of the above lemmas because we only have to modify slightly the proofs in the case of $\delta = 1$.

The following proposition is a slight modification of the energy estimate obtained in [15].

Proposition 3.3. *There exists a positive constant R_0 such that if $0 < R \leq R_0$, then the solution (η, u, v, p) of (2.28)–(2.30) satisfies*

$$\begin{aligned} (3.1) \quad & \frac{\delta}{2} \frac{d}{dt} \left\{ \|\mathbf{u}^\delta\|^2 + \frac{2}{R} \left(\frac{1}{\tan \alpha} |\eta|_0^2 + \frac{\delta^2 W}{\sin \alpha} |\eta_x|_0^2 \right) \right\} + \frac{1}{4KR} \|\nabla_\delta \mathbf{u}^\delta\|^2 \\ & \leq \frac{4K}{R} (|\eta|_0^2 + |b_3 \eta|_0^2) + \frac{1}{R} (h_1, u)_\Gamma - \frac{2}{R} (h_2, \delta v)_\Gamma \\ & \quad + \frac{2}{R} \left(\frac{1}{\tan \alpha} \eta - \frac{\delta^2 W}{\sin \alpha} \eta_{xx}, \delta h_3 \right)_\Gamma + (\mathbf{F}_1, \mathbf{u}^\delta)_\Omega, \end{aligned}$$

where K is the constant in Korn's inequality and

$$(3.2) \quad \mathbf{F}_1 = \mathbf{f} - \frac{2}{R} A_4 \nabla_\delta p + \frac{1}{R} \begin{pmatrix} b_2 u_{yy} \\ 0 \end{pmatrix}.$$

Proof. Note that Lemma 3.1 implies

$$(3.3) \quad \|\nabla_\delta \mathbf{u}^\delta\|^2 \leq K \|\mathbf{u}^\delta\|^2,$$

where $\|\mathbf{u}^\delta\|^2 = 2\|\delta u_x\|^2 + \|u_y + \delta^2 v_x\|^2 + 2\|\delta v_y\|^2$. Taking the inner product of \mathbf{u}^δ with the first equation in (2.28), we have

$$(3.4) \quad \frac{\delta}{2} \frac{d}{dt} \|\mathbf{u}^\delta\|^2 + (u, \bar{u}_y \delta v)_\Omega + \frac{1}{R} (2\nabla_\delta p - \Delta_\delta \mathbf{u}^\delta, \mathbf{u}^\delta)_\Omega = (\mathbf{F}_1, \mathbf{u}^\delta)_\Omega.$$

Using the second equation in (2.28) and integration by parts in x and y , we see that

$$\begin{aligned}
& (2\nabla_\delta p - \Delta_\delta \mathbf{u}^\delta, \mathbf{u}^\delta)_\Omega \\
&= 2(p, \delta v)_\Gamma - (2\delta^2 u_{xx} + \delta^2 v_{xy} + u_{yy}, u)_\Omega - (\delta^3 v_{xx} + 2\delta v_{yy} + \delta u_{xy}, \delta v)_\Omega \\
&= 2(p, \delta v)_\Gamma + 2\|\delta u_x\|^2 + (\delta^2 v_x + u_y, u_y)_\Omega - (\delta^2 v_x + u_y, u)_\Gamma \\
&\quad + 2\|\delta v_y\|^2 - 2(\delta v_y, \delta v)_\Gamma + (\delta^2 v_x + u_y, \delta^2 v_x)_\Omega \\
&= \|\mathbf{u}^\delta\|^2 + 2(p - \delta v_y, \delta v)_\Gamma - (\delta^2 v_x + u_y, u)_\Gamma.
\end{aligned}$$

By (2.29) and integration by parts in x , the boundary terms in the right-hand side of the above equality are calculated as

$$\begin{aligned}
(3.5) \quad 2(p - \delta v_y, \delta v)_\Gamma &= 2\left(\frac{1}{\tan \alpha} \eta - \frac{\delta^2 W}{\sin \alpha} \eta_{xx}, \delta(\eta_t + \eta_x - h_3)\right)_\Gamma + 2(h_2, \delta v)_\Gamma \\
&= \delta \frac{d}{dt} \left\{ \frac{1}{\tan \alpha} |\eta|_0^2 + \frac{\delta^2 W}{\sin \alpha} |\eta_x|_0^2 \right\} + 2(h_2, \delta v)_\Gamma \\
&\quad - 2\left(\frac{1}{\tan \alpha} \eta - \frac{\delta^2 W}{\sin \alpha} \eta_{xx}, \delta h_3\right)_\Gamma
\end{aligned}$$

and $-(\delta^2 v_x + u_y, u)_\Gamma = -((2 + b_3)\eta, u)_\Gamma - (h_1, u)_\Gamma$. Moreover, by the Cauchy-Schwarz and Poincaré's inequalities we see that $|(u, \bar{u}_y \delta v)_\Omega| \leq 2\|u\| \|\delta v\| \leq \|\mathbf{u}^\delta\|^2 \leq \|\mathbf{u}_y^\delta\|^2 \leq \|\nabla_\delta \mathbf{u}^\delta\|^2$ and that $\frac{2}{R}|(\eta, u)_\Gamma| \leq \frac{2}{R}|\eta|_0 \|u_y\| \leq \frac{1}{4KR} \|u_y\|^2 + \frac{4K}{R} |\eta|_0^2$. Here, we used the inequality $|u(\cdot, 1)|_0 = |u(\cdot, 1) - u(\cdot, 0)|_0 \leq \|u_y\|$ thanks to the boundary condition (2.30). In the following, we use frequently this type of inequality without any comment. Thus we can rewrite (3.4) as

$$\begin{aligned}
& \frac{\delta}{2} \frac{d}{dt} \left\{ \|\mathbf{u}^\delta\|^2 + \frac{2}{R} \left(\frac{1}{\tan \alpha} |\eta|_0^2 + \frac{\delta^2 W}{\sin \alpha} |\eta_x|_0^2 \right) \right\} + \frac{1}{2KR} \|\nabla_\delta \mathbf{u}^\delta\|^2 \\
& \leq \|\nabla_\delta \mathbf{u}^\delta\|^2 + \frac{4K}{R} (|\eta|_0^2 + |b_3 \eta|_0^2) + \frac{1}{R} (h_1, u)_\Gamma - \frac{2}{R} (h_2, \delta v)_\Gamma \\
& \quad + \frac{2}{R} \left(\frac{1}{\tan \alpha} \eta - \frac{\delta^2 W}{\sin \alpha} \eta_{xx}, \delta h_3 \right)_\Gamma + (\mathbf{F}_1, \mathbf{u}^\delta)_\Omega,
\end{aligned}$$

where we used Korn's inequality (3.3). Therefore, taking R_0 sufficiently small so that $4KR_0 \leq 1$, for $0 < R \leq R_0$ we obtain the desired energy estimate. \square

Note that we can take the tangential and time derivatives of the boundary conditions. Applying $\delta \partial_x$, $\delta^2 \partial_x^2$, and $\delta \partial_t$ to (2.28)–(2.30) and using the above proposition, we obtain

$$\begin{aligned}
(3.6) \quad \frac{1}{2} \frac{d}{dt} \left\{ \delta^2 \|\mathbf{u}_x^\delta\|^2 + \frac{2}{R} \left(\frac{1}{\tan \alpha} \delta^2 |\eta_x|_0^2 + \frac{\delta^2 W}{\sin \alpha} \delta^2 |\eta_{xx}|_0^2 \right) \right\} &+ \frac{1}{4KR} \delta \|\nabla_\delta \mathbf{u}_x^\delta\|^2 \\
&\leq \frac{4K}{R} (\delta |\eta_x|_0^2 + \delta |(b_3 \eta)_x|_0^2) + \frac{1}{R} \delta (h_{1x}, u_x)_\Gamma - \frac{2}{R} \delta (h_{2x}, \delta v_x)_\Gamma \\
&\quad + \frac{2}{R} \delta \left(\frac{1}{\tan \alpha} \eta_x - \frac{\delta^2 W}{\sin \alpha} \eta_{xxx}, \delta h_{3x} \right)_\Gamma + \delta (\mathbf{F}_{1x}, \mathbf{u}_x^\delta)_\Omega,
\end{aligned}$$

$$\begin{aligned}
(3.7) \quad \frac{1}{2} \frac{d}{dt} \left\{ \delta^4 \|\mathbf{u}_{xx}^\delta\|^2 + \frac{2}{R} \left(\frac{1}{\tan \alpha} \delta^4 |\eta_{xx}|_0^2 + \frac{\delta^2 W}{\sin \alpha} \delta^4 |\eta_{xxx}|_0^2 \right) \right\} &+ \frac{1}{4KR} \delta^3 \|\nabla_\delta \mathbf{u}_{xx}^\delta\|^2 \\
&\leq \frac{4K}{R} (\delta^3 |\eta_{xx}|_0^2 + \delta^3 |(b_3 \eta)_{xx}|_0^2) + \frac{1}{R} \delta^3 (h_{1xx}, u_{xx})_\Gamma - \frac{2}{R} \delta^3 (h_{2xx}, \delta v_{xx})_\Gamma \\
&\quad + \frac{2}{R} \delta^3 \left(\frac{1}{\tan \alpha} \eta_{xx} - \frac{\delta^2 W}{\sin \alpha} \eta_{xxxx}, \delta h_{3xx} \right)_\Gamma + \delta^3 (\mathbf{F}_{1xx}, \mathbf{u}_{xx}^\delta)_\Omega,
\end{aligned}$$

$$\begin{aligned}
(3.8) \quad & \frac{1}{2} \frac{d}{dt} \left\{ \delta^2 \|\mathbf{u}_t^\delta\|^2 + \frac{2}{R} \left(\frac{1}{\tan \alpha} \delta^2 |\eta_t|_0^2 + \frac{\delta^2 W}{\sin \alpha} \delta^2 |\eta_{tx}|_0^2 \right) \right\} + \frac{1}{4KR} \delta \|\nabla_\delta \mathbf{u}_t^\delta\|^2 \\
& \leq \frac{4K}{R} (\delta |\eta_t|_0^2 + \delta |(b_3 \eta)_t|_0^2) + \frac{1}{R} \delta (h_{1t}, u_t)_\Gamma - \frac{2}{R} \delta (h_{2t}, \delta v_t)_\Gamma \\
& \quad + \frac{2}{R} \delta \left(\frac{1}{\tan \alpha} \eta_t - \frac{\delta^2 W}{\sin \alpha} \eta_{txx}, \delta h_{3t} \right)_\Gamma \\
& \quad + \delta (\mathbf{f}_t, \mathbf{u}_t^\delta)_\Omega - \frac{2}{R} \delta ((A_4 \nabla_\delta p)_t, \mathbf{u}_t^\delta)_\Omega + \frac{1}{R} \delta ((b_2 u_{yy})_t, u_t)_\Omega.
\end{aligned}$$

For later use, we will compute $-\frac{2}{R} \delta (\partial_x^k (A_4 \nabla_\delta p)_t, \partial_x^k \mathbf{u}_t^\delta)_\Omega$ for a nonnegative integer k . Applying $\delta \partial_t$ to the first equation in (2.28), we have

$$(3.9) \quad \delta^2 \mathbf{u}_{tt}^\delta = -\frac{2}{R} \delta (I + A_4) \nabla_\delta p_t - \frac{2}{R} \delta A_{4t} \nabla_\delta p + \delta \mathbf{F}_{3t},$$

where

$$(3.10) \quad \mathbf{F}_3 = -(\mathbf{U} \cdot \nabla_\delta) \mathbf{u}^\delta - (\mathbf{u}^\delta \cdot \nabla_\delta) \mathbf{U} + \frac{1}{R} (\delta^2 \mathbf{u}_{xx}^\delta + (I + A_3) \mathbf{u}_{yy}^\delta) + \mathbf{f}.$$

Moreover, we can rewrite (2.28) as

$$(3.11) \quad \frac{2}{R} A_4 \nabla_\delta p = -\delta A_5 \mathbf{u}_t^\delta + A_5 \mathbf{F}_3,$$

where $A_5 = A_4(I + A_4)^{-1}$. Note that A_5 is a symmetric matrix due to the symmetry of A_4 (see (2.21)). Applying $\delta \partial_x^k \partial_t$ to the above equation, we have

$$\frac{2}{R} \delta \partial_x^k (A_4 \nabla_\delta p)_t = -\delta^2 A_5 \partial_x^k \mathbf{u}_{tt}^\delta - \delta^2 \partial_x^k (A_{5t} \mathbf{u}_t^\delta) - \delta^2 [\partial_x^k, A_5] \mathbf{u}_{tt}^\delta + \delta \partial_x^k (A_5 \mathbf{F}_3)_t.$$

This together with (3.9) yields

$$\begin{aligned}
(3.12) \quad & -\frac{2}{R} \delta (\partial_x^k (A_4 \nabla_\delta p)_t, \partial_x^k \mathbf{u}_t^\delta)_\Omega = \frac{1}{2} \frac{d}{dt} \delta^2 (A_5 \partial_x^k \mathbf{u}_t^\delta, \partial_x^k \mathbf{u}_t^\delta)_\Omega \\
& \quad + \delta (\partial_x^k \{ \frac{1}{2} \delta A_{5t} \mathbf{u}_t^\delta - (A_5 \mathbf{F}_3)_t \}, \partial_x^k \mathbf{u}_t^\delta)_\Omega + \delta (\mathbf{G}_k, \partial_x^k \mathbf{u}_t^\delta)_\Omega,
\end{aligned}$$

where

$$(3.13) \quad \mathbf{G}_k = [\partial_x^k, A_5] \left\{ -\frac{2}{R} (I + A_4) \nabla_\delta p_t - \frac{2}{R} A_{4t} \nabla_\delta p + \mathbf{F}_{3t} \right\} + \frac{1}{2} \delta [\partial_x^k, A_{5t}] \mathbf{u}_t^\delta.$$

In Particular, in the case of $k = 0$, we have

$$-\frac{2}{R} \delta ((A_4 \nabla_\delta p)_t, \mathbf{u}_t^\delta)_\Omega = \frac{1}{2} \frac{d}{dt} \delta^2 (A_5 \mathbf{u}_t^\delta, \mathbf{u}_t^\delta)_\Omega + \delta \left(\frac{1}{2} \delta A_{5t} \mathbf{u}_t^\delta - (A_5 \mathbf{F}_3)_t, \mathbf{u}_t^\delta \right)_\Omega.$$

By substituting this into (3.8), we get

$$\begin{aligned}
(3.14) \quad & \frac{1}{2} \frac{d}{dt} \left\{ \delta^2 ((I - A_5) \mathbf{u}_t^\delta, \mathbf{u}_t^\delta)_\Omega + \frac{2}{R} \left(\frac{1}{\tan \alpha} \delta^2 |\eta_t|_0^2 + \frac{\delta^2 W}{\sin \alpha} \delta^2 |\eta_{tx}|_0^2 \right) \right\} + \frac{1}{4KR} \delta \|\nabla_\delta \mathbf{u}_t^\delta\|^2 \\
& \leq \frac{4K}{R} (\delta |\eta_t|_0^2 + \delta |(b_3 \eta)_t|_0^2) + \frac{1}{R} \delta (h_{1t}, u_t)_\Gamma - \frac{2}{R} \delta (h_{2t}, \delta v_t)_\Gamma \\
& \quad + \frac{2}{R} \delta \left(\frac{1}{\tan \alpha} \eta_t - \frac{\delta^2 W}{\sin \alpha} \eta_{txx}, \delta h_{3t} \right)_\Gamma + \delta (\mathbf{F}_2, \mathbf{u}_t^\delta)_\Omega,
\end{aligned}$$

where

$$(3.15) \quad \mathbf{F}_2 = \mathbf{f}_t + \frac{1}{\mathbf{R}} \begin{pmatrix} (b_2 u_{yy})_t \\ 0 \end{pmatrix} + \frac{1}{2} \delta A_{5t} \mathbf{u}_t^\delta - (A_5 \mathbf{F}_3)_t.$$

Note that $I - A_5$ is positive definite for small solutions.

The lowest order energy obtained in (3.1) is not appropriate in order to get the uniform estimate in δ , which is our goal in this paper. We thereby need to modify the lowest energy estimate. Now it follows from the first and second equations in (2.28) that

$$\delta^2 v_t + \bar{u} \delta^2 v_x + \frac{2}{\mathbf{R}} p_y - \frac{1}{\mathbf{R}} \delta (\delta^2 v_x + u_y)_x - \frac{2}{\mathbf{R}} \delta v_{yy} = f_1,$$

where

$$(3.16) \quad f_1 = \left(\mathbf{f} - \frac{2}{\mathbf{R}} A_4 \nabla_\delta p \right) \cdot \mathbf{e}_2.$$

Taking the inner product of δv with the above equation, we obtain

$$\frac{\delta}{2} \frac{d}{dt} \delta^2 \|v\|^2 - \frac{2}{\mathbf{R}} (p, \delta v_y)_\Omega + \frac{1}{\mathbf{R}} (\delta^2 v_x + u_y, \delta^2 v_x)_\Omega + \frac{2}{\mathbf{R}} \delta^2 \|v_y\|^2 + \frac{2}{\mathbf{R}} (p - \delta v_y, \delta v)_\Gamma = (f_1, \delta v)_\Omega.$$

Thus using the second equation in (2.28) and integration by parts in x , we have

$$(3.17) \quad \begin{aligned} & \frac{\delta}{2} \frac{d}{dt} \delta^2 \|v\|^2 + \frac{2}{\mathbf{R}} (p - \delta v_y, \delta v)_\Gamma + \frac{1}{\mathbf{R}} \delta^4 \|v_x\|^2 + \frac{2}{\mathbf{R}} \delta^2 \|v_y\|^2 \\ & = \frac{2}{\mathbf{R}} (\delta p_x, u)_\Omega + \frac{1}{\mathbf{R}} (\delta u_{xy}, \delta v)_\Omega + (f_1, \delta v)_\Omega. \end{aligned}$$

Lemma 3.4. *The following inequality holds.*

$$\begin{aligned} & \frac{2}{\mathbf{R}} (\delta p_x, u)_\Omega + \frac{1}{3\mathbf{R}} \left(\frac{1}{\tan^2 \alpha} \delta^2 |\eta_x|_0^2 + \frac{2\delta^2 \mathbf{W}}{\tan \alpha \sin \alpha} \delta^2 |\eta_{xx}|_0^2 + \frac{(\delta^2 \mathbf{W})^2}{\sin^2 \alpha} \delta^2 |\eta_{xxx}|_0^2 \right) + \frac{1}{\mathbf{R}} \delta^2 \|\partial_y^{-1} p_x\|^2 \\ & \leq I_1 + I_2 + I_3, \end{aligned}$$

where

$$\begin{cases} I_1 = -\frac{2}{\mathbf{R}} (\delta \partial_y^{-1} p_x, (2 + b_3) \eta)_\Omega, \\ I_2 = -\frac{2}{\mathbf{R}} (\delta \partial_y^{-1} p_x, -\delta^2 v_x(\cdot, 1) + h_1 + \partial_y^{-1} (u_{yy} - 2\delta p_x))_\Omega, \\ I_3 = \frac{1}{\mathbf{R}} (2\delta^4 |u_{xx}|_0^2 + 2\delta^2 |h_{2x}|_0^2 + 3\delta^2 \|\partial_y^{-2} p_{xy}\|^2). \end{cases}$$

Proof. By the first equation in (2.29) and (2.30), we see that

$$(3.18) \quad \begin{aligned} \frac{2}{\mathbf{R}} (\delta p_x, u)_\Omega & = -\frac{2}{\mathbf{R}} (\partial_y^{-1} \delta p_x, u_y)_\Omega = -\frac{2}{\mathbf{R}} (\partial_y^{-1} \delta p_x, u_y(\cdot, 1) + \partial_y^{-1} u_{yy})_\Omega \\ & = -\frac{2}{\mathbf{R}} (\partial_y^{-1} \delta p_x, (2 + b_3) \eta - \delta^2 v_x(\cdot, 1) + h_1 + 2\partial_y^{-1} \delta p_x + \partial_y^{-1} (u_{yy} - 2\delta p_x))_\Omega \\ & = -\frac{4}{\mathbf{R}} \delta^2 \|\partial_y^{-1} p_x\|^2 + I_1 + I_2. \end{aligned}$$

On the other hand, it follows from the second equations in (2.28) and (2.29) that

$$(3.19) \quad \begin{aligned} p(x, y) & = p(x, 1) + (\partial_y^{-1} p_y)(x, y) \\ & = -\delta u_x(x, 1) + \frac{1}{\tan \alpha} \eta - \frac{\delta^2 \mathbf{W}}{\sin \alpha} \eta_{xx} + h_2 + (\partial_y^{-1} p_y)(x, y). \end{aligned}$$

Thus applying $\delta R^{-\frac{1}{2}} \partial_y^{-1} \partial_x$ to the above equation, we obtain

$$\begin{aligned} & \frac{y-1}{R^{\frac{1}{2}}} \left(\frac{1}{\tan \alpha} \delta \eta_x - \frac{\delta^2 W}{\sin \alpha} \delta \eta_{xxx} \right) \\ &= \frac{\delta}{R^{\frac{1}{2}}} (\partial_y^{-1} p_x)(x, y) + \frac{y-1}{R^{\frac{1}{2}}} (\delta^2 u_{xx}(x, 1) - \delta h_{2x}) - \frac{\delta}{R^{\frac{1}{2}}} (\partial_y^{-2} p_{xy})(x, y). \end{aligned}$$

Squaring both sides of the above equation and integrating the resulting equality on Ω , we have

$$\frac{1}{3R} \left(\frac{1}{\tan^2 \alpha} \delta^2 |\eta_x|_0^2 + \frac{2\delta^2 W}{\tan \alpha \sin \alpha} \delta^2 |\eta_{xx}|_0^2 + \frac{(\delta^2 W)^2}{\sin^2 \alpha} \delta^2 |\eta_{xxx}|_0^2 \right) \leq \frac{3}{R} \delta^2 \|\partial_y^{-1} p_x\|^2 + I_3,$$

where we used integration by parts in x . This and (3.18) lead to the desired inequality. \square

This lemma together with (3.5) and (3.17) implies that

$$\begin{aligned} (3.20) \quad & \frac{1}{2} \frac{d}{dt} \left\{ \delta^2 \|v\|^2 + \frac{2}{R} \left(\frac{1}{\tan \alpha} |\eta|_0^2 + \frac{\delta^2 W}{\sin \alpha} |\eta_x|_0^2 \right) \right\} + \frac{1}{R} (\delta^3 \|v_x\|^2 + 2\delta \|v_y\|^2 + \delta \|\partial_y^{-1} p_x\|^2) \\ & + \frac{1}{3R} \left(\frac{1}{\tan^2 \alpha} \delta |\eta_x|_0^2 + \frac{2\delta^2 W}{\tan \alpha \sin \alpha} \delta |\eta_{xx}|_0^2 + \frac{(\delta^2 W)^2}{\sin^2 \alpha} \delta |\eta_{xxx}|_0^2 \right) \\ & \leq -\frac{2}{R} (h_2, v)_\Gamma + \frac{1}{R} \delta (u_{xy}, v)_\Omega + (f_1, v)_\Omega + \frac{2}{R} \left(\frac{1}{\tan \alpha} \eta - \frac{\delta^2 W}{\sin \alpha} \eta_{xx}, h_3 \right)_\Gamma \\ & + \delta^{-1} (I_1 + I_2 + I_3). \end{aligned}$$

The first three terms in the right-hand side are estimated as

$$-\frac{2}{R} (h_2, v)_\Gamma + \frac{1}{R} \delta (u_{xy}, v)_\Omega + (f_1, v)_\Omega \leq \frac{1}{R} \delta \|v_y\|^2 + \frac{1}{R} (2\delta^{-1} |h_2|_0^2 + \delta \|u_{xy}\|^2) + R \|f_1\|^2$$

and the first term in the right-hand side can be absorbed in the left-hand side of (3.20). We proceed to estimate I_1 , I_2 , and I_3 . By (3.19) and integration by parts in x , I_1 is rewritten as

$$\begin{aligned} (3.21) \quad I_1 &= -\frac{2}{R} (\delta \partial_y^{-1} \left(-\delta u_x(\cdot, 1) + \frac{1}{\tan \alpha} \eta - \frac{\delta^2 W}{\sin \alpha} \eta_{xx} + h_2 + \partial_y^{-1} p_y \right)_x, (2 + b_3) \eta)_\Omega \\ &= I_4 + I_5, \end{aligned}$$

where

$$\begin{aligned} (3.22) \quad I_4 &= \frac{2}{R} ((y-1)(-\delta u_x(\cdot, 1) + h_2) + \partial_y^{-2} p_y, \delta((2 + b_3) \eta)_x)_\Omega, \\ I_5 &= -\frac{1}{R} \left(\frac{1}{\tan \alpha} \eta - \frac{\delta^2 W}{\sin \alpha} \eta_{xx}, \delta(b_3 \eta)_x \right)_\Gamma. \end{aligned}$$

Here we used identities $(\eta, \eta_x)_\Gamma = (\eta_{xx}, \eta_x)_\Gamma = 0$. We estimate I_2 , I_3 , and I_4 as follows.

Lemma 3.5. *There exists a positive constant C independent of δ , R , W , and α such that the*

following estimates hold.

$$\begin{aligned}
|I_2| &\leq \frac{1}{2\mathbf{R}}\delta^2\|\partial_y^{-1}p_x\|^2 + C\left\{\frac{1}{\mathbf{R}}(\delta^4\|v_{xy}\|^2 + |h_1|_0^2 + \delta^4\|u_{xx}\|^2) \right. \\
&\quad \left. + \mathbf{R}(\delta^2\|u_{ty}\|^2 + \delta^2\|u_x\|^2 + \delta^2\|v_y\|^2 + \|f_2\|^2)\right\}, \\
|I_3| &\leq C\left\{\frac{1}{\mathbf{R}}(\delta^4\|u_{xxy}\|^2 + \delta^2|h_{2x}|_0^2 + \delta^8\|v_{xxx}\|^2 + \delta^4\|v_{xyy}\|^2) \right. \\
&\quad \left. + \mathbf{R}(\delta^6\|v_{tx}\|^2 + \delta^6\|v_{xx}\|^2 + \delta^2\|f_{1x}\|^2)\right\}, \\
|I_4| &\leq \frac{1}{6\mathbf{R}\tan^2\alpha}(\delta^2|\eta_x|_0^2 + \delta^2|(b_3\eta)_x|_0^2) \\
&\quad + C\left\{\frac{\tan^2\alpha}{\mathbf{R}}(\delta^2\|u_{xy}\|^2 + \delta^6\|v_{xx}\|^2 + \delta^2\|v_{yy}\|^2 + |h_2|_0^2) \right. \\
&\quad \left. + \mathbf{R}\tan^2\alpha(\delta^4\|v_{ty}\|^2 + \delta^4\|v_x\|^2 + \|f_1\|^2)\right\},
\end{aligned}$$

where

$$(3.23) \quad f_2 = -\frac{b_2}{1+b_2}\left(\delta u_t + \bar{u}\delta u_x + \bar{u}_y\delta v - \frac{1}{\mathbf{R}}\delta^2 u_{xx}\right) - \frac{2b_2}{\mathbf{R}(1+b_2)}\delta p_x - \frac{1}{1+b_2}f_3$$

$$\text{and } f_3 = (\mathbf{f} - \frac{2}{\mathbf{R}}A_4\nabla_\delta p) \cdot \mathbf{e}_1.$$

Proof. We can easily estimate I_3 and I_4 by using the second component of the first equation in (2.28) so as to eliminate p_y . As for I_2 , by the first component of the first equation in (2.28), we have

$$\frac{1}{\mathbf{R}}\left(u_{yy} - \frac{2}{1+b_2}\delta p_x\right) = \frac{1}{1+b_2}\left(\delta u_t + \bar{u}\delta u_x + \bar{u}_y\delta v - \frac{1}{\mathbf{R}}\delta^2 u_{xx}\right) - \frac{1}{1+b_2}f_3.$$

Substituting the above equation into I_2 , we easily obtain the desired estimate. \square

Combining (3.20), (3.21), and Lemma 3.5, we obtain

$$\begin{aligned}
(3.24) \quad &\frac{1}{2}\frac{d}{dt}\left\{\delta^2\|v\|^2 + \frac{2}{\mathbf{R}}\left(\frac{1}{\tan\alpha}|\eta|_0^2 + \frac{\delta^2\mathbf{W}}{\sin\alpha}|\eta_x|_0^2\right)\right\} + \frac{1}{\mathbf{R}}\left(\delta\|\mathbf{u}_x^\delta\|^2 + \frac{1}{2}\delta\|\partial_y^{-1}p_x\|^2\right) \\
&\quad + \frac{1}{3\mathbf{R}}\left(\frac{1}{2\tan^2\alpha}\delta|\eta_x|_0^2 + \frac{2\delta^2\mathbf{W}}{\tan\alpha\sin\alpha}\delta|\eta_{xx}|_0^2 + \frac{(\delta^2\mathbf{W})^2}{\sin^2\alpha}\delta|\eta_{xxx}|_0^2\right) \\
&\leq C_1\left\{\frac{1}{\mathbf{R}}((1+\tan^2\alpha)\delta\|\nabla_\delta\mathbf{u}_x^\delta\|^2 + \delta^3\|\nabla_\delta\mathbf{u}_{xx}^\delta\|^2 \right. \\
&\quad \left. + \delta^{-1}|h_1|_0^2 + (1+\tan^2\alpha)\delta^{-1}|h_2|_0^2 + \delta|h_{2x}|_0^2) \right. \\
&\quad \left. + \mathbf{R}(\delta\|\nabla_\delta\mathbf{u}_x^\delta\|^2 + (1+\tan^2\alpha)\delta\|\nabla_\delta\mathbf{u}_t^\delta\|^2 \right. \\
&\quad \left. + (1+\tan^2\alpha)\delta^{-1}\|f_1\|^2 + \delta^{-1}\|f_2\|^2 + \delta\|f_{1x}\|^2)\right\} \\
&\quad + \frac{2\delta^2\mathbf{W}}{\mathbf{R}\sin\alpha}\delta^{-1}|(\eta_{xx}, \delta h_3)_\Gamma| + \frac{1}{6\mathbf{R}\tan^2\alpha}\delta|(b_3\eta)_x|_0^2 + \delta^{-1}I_5,
\end{aligned}$$

where we used the second equation in (2.28) and $(\eta, h_3)_\Gamma = (\eta, \varepsilon^2\eta^2\eta_x)_\Gamma = 0$. Here the constant C_1 does not depend on δ , \mathbf{R} , \mathbf{W} , nor α . This is the modified energy estimate. In the left-hand side, we have a new term $\delta\|\partial_y^{-1}p_x\|^2$, which plays an important role in this paper.

In view of the energy estimates obtained in this section, we define an energy function E_0 , a dissipation function F_0 , and a collection of the nonlinear terms N_0 by

$$(3.25) \quad \begin{aligned} E_0(\eta, \mathbf{u}^\delta) &= \delta^2 \|v\|^2 + \frac{2}{\mathbf{R}} \left(\frac{1}{\tan \alpha} |\eta|_0^2 + \frac{\delta^2 \mathbf{W}}{\sin \alpha} |\eta_x|_0^2 \right) \\ &\quad + \beta_1 \left\{ \delta^2 \|\mathbf{u}_x^\delta\|^2 + \frac{2}{\mathbf{R}} \left(\frac{1}{\tan \alpha} \delta^2 |\eta_x|_0^2 + \frac{\delta^2 \mathbf{W}}{\sin \alpha} \delta^2 |\eta_{xx}|_0^2 \right) \right\} \\ &\quad + \beta_2 \left\{ \delta^4 \|\mathbf{u}_{xx}^\delta\|^2 + \frac{2}{\mathbf{R}} \left(\frac{1}{\tan \alpha} \delta^4 |\eta_{xx}|_0^2 + \frac{\delta^2 \mathbf{W}}{\sin \alpha} \delta^4 |\eta_{xxx}|_0^2 \right) \right\} \\ &\quad + \beta_3 \left\{ \delta^2 ((I - A_5) \mathbf{u}_t^\delta, \mathbf{u}_t^\delta)_\Omega + \frac{2}{\mathbf{R}} \left(\frac{1}{\tan \alpha} \delta^2 |\eta_t|_0^2 + \frac{\delta^2 \mathbf{W}}{\sin \alpha} \delta^2 |\eta_{tx}|_0^2 \right) \right\}, \end{aligned}$$

$$(3.26) \quad \begin{aligned} F_0(\eta, \mathbf{u}^\delta, p) &= \frac{1}{2\mathbf{R}} \left(\delta \|\mathbf{u}_x^\delta\|^2 + \frac{1}{2} \delta \|\partial_y^{-1} p_x\|^2 \right) \\ &\quad + \frac{1}{6\mathbf{R}} \left(\frac{1}{2 \tan^2 \alpha} \delta |\eta_x|_0^2 + \frac{2\delta^2 \mathbf{W}}{\tan \alpha \sin \alpha} \delta |\eta_{xx}|_0^2 + \frac{(\delta^2 \mathbf{W})^2}{\sin^2 \alpha} \delta |\eta_{xxx}|_0^2 \right) \\ &\quad + \frac{1}{8K\mathbf{R}} (\beta_1 \delta \|\nabla_\delta \mathbf{u}_x^\delta\|^2 + \beta_2 \delta^3 \|\nabla_\delta \mathbf{u}_{xx}^\delta\|^2 + \beta_3 \delta \|\nabla_\delta \mathbf{u}_t^\delta\|^2), \end{aligned}$$

$$(3.27) \quad \begin{aligned} N_0(Z) &= \delta^{-1} |h_1|_0^2 + \delta^{-1} |h_2|_0^2 + \delta |h_{1x}|_0^2 + \delta |h_{2x}|_0^2 \\ &\quad + \delta |h_3|_0^2 + \delta^3 |h_{3t}|_0^2 + \delta^3 |h_{3x}|_0^2 + \delta^5 |h_{3xx}|_0^2 \\ &\quad + \delta^2 \| |D_x|^{\frac{1}{2}} h_{1x} \|_0^2 + \delta^2 \| |D_x|^{\frac{1}{2}} h_{2x} \|_0^2 + \delta |(h_{1t}, u_t)_\Gamma| + \delta |(h_{2t}, \delta v_t)_\Gamma| \\ &\quad + \delta |(b_3 \eta)_x|_0^2 + \delta^3 |(b_3 \eta)_{xx}|_0^2 + \delta |(b_3 \eta)_t|_0^2 + |(\eta, (b_3 \eta)_x)_\Gamma| \\ &\quad + \delta^2 \mathbf{W} \{ \delta^{-1} |(\eta_{xx}, \delta h_3 + \delta (b_3 \eta)_x)_\Gamma| + \delta^3 |(\eta_{xxx}, \delta h_{3xx})_\Gamma| + \delta |(\eta_{xxt}, \delta h_{3t})_\Gamma| \} \\ &\quad + \delta^{-1} \|f_1\|^2 + \delta^{-1} \|f_2\|^2 + \delta \|f_{1x}\|^2 \\ &\quad + \delta |(\mathbf{F}_{1x}, \mathbf{u}_x^\delta)_\Omega| + \delta^3 |(\mathbf{F}_{1xx}, \mathbf{u}_{xx}^\delta)_\Omega| + \delta |(\mathbf{F}_2, \mathbf{u}_t^\delta)_\Omega|, \end{aligned}$$

where $Z = (\eta, \mathbf{u}^\delta, h_1, h_2, h_3, b_3 \eta, f_1, f_2, \mathbf{F}_1, \mathbf{F}_2)$ and we will determine the constants β_1 , β_2 , and β_3 later. Note that the terms $|(\eta, (b_3 \eta)_x)_\Gamma|$ and $(\delta^2 \mathbf{W}) \delta^{-1} |(\eta_{xx}, \delta (b_3 \eta)_x)_\Gamma|$ come from I_5 . Summarizing our energy estimates, we obtain the following proposition.

Proposition 3.6. *Let W_1 be a positive constant. There exists a positive constant α_0 such that if $0 < \mathbf{R}_1 \leq \mathbf{R} \leq \mathbf{R}_0$, $W_1 \leq W$, and $0 < \alpha \leq \alpha_0$, then the solution (η, u, v, p) of (2.28)–(2.30) satisfies*

$$\frac{d}{dt} E_0 + F_0 \leq C_2 N_0,$$

where \mathbf{R}_0 is the constant in Proposition 3.3 and the constant $C_2(\mathbf{R}_1, W_1, \alpha)$ is independent of δ , \mathbf{R} , and W .

Proof. Multiplying (3.6), (3.7), and (3.14) by β_1 , β_2 , and β_3 , respectively, and adding these and (3.24), we see that

$$\frac{d}{dt} E_0 + 2F_0 \leq L + C(N + N_0),$$

where

$$\begin{aligned}
L &= \frac{4K}{\mathbf{R}}((\beta_1 + 3\beta_3)\delta|\eta_x|_0^2 + \beta_2\delta^3|\eta_{xx}|_0^2) + \left\{ C_1 \left(\frac{1 + \tan^2 \alpha}{\mathbf{R}} + \mathbf{R} \right) + \frac{12K}{\mathbf{R}}\beta_3 \right\} \delta \|\nabla_\delta \mathbf{u}_x^\delta\|^2 \\
&\quad + \frac{C_1}{\mathbf{R}}\delta^3 \|\nabla_\delta \mathbf{u}_{xx}^\delta\|^2 + C_1 \mathbf{R} (1 + \tan^2 \alpha) \delta \|\nabla_\delta \mathbf{u}_t^\delta\|^2, \\
N &= \delta |(h_{1x}, u_x)_\Gamma| + \delta |(h_{2x}, \delta v_x)_\Gamma| + \delta |(\eta_x, \delta h_{3x})_\Gamma| + |((\delta^2 \mathbf{W})\delta^{1/2}\eta_{xxx}, \delta^{3/2}h_{3x})_\Gamma| \\
&\quad + \delta^3 |(h_{1xx}, u_{xx})_\Gamma| + \delta^3 |(h_{2xx}, \delta v_{xx})_\Gamma| + \delta^3 |(\eta_{xx}, \delta h_{3xx})_\Gamma| + \delta |(\eta_t, \delta h_{3t})_\Gamma| + \delta^{-1} |I_5|.
\end{aligned}$$

Here we used $|\eta_t|_0 \leq |\eta_x|_0 + \|u_{xy}\| + |h_3|_0$, which comes from the second equation in (2.28), the third equation in (2.29), and Poincaré's inequality. Moreover, it is easy to see that for any $\epsilon > 0$ there exists a constant $C_\epsilon > 0$ such that $N \leq \epsilon F_0 + C_\epsilon N_0$. Therefore, if we take $(\beta_1, \beta_2, \beta_3)$ so that

$$(3.28) \quad \begin{cases} \frac{4K}{\mathbf{R}}(\beta_1 + 3\beta_3) < \frac{1}{12\mathbf{R}\tan^2 \alpha}, & \frac{4K}{\mathbf{R}}\beta_2 < \frac{\mathbf{W}}{3\mathbf{R}\tan \alpha \sin \alpha}, \\ C_1 \left(\frac{1 + \tan^2 \alpha}{\mathbf{R}} + \mathbf{R} \right) + \frac{12K}{\mathbf{R}}\beta_3 < \frac{\beta_1}{8K\mathbf{R}}, & \frac{C_1}{\mathbf{R}} < \frac{\beta_2}{8K\mathbf{R}}, & C_1 \mathbf{R} (1 + \tan^2 \alpha) < \frac{\beta_3}{8K\mathbf{R}}, \end{cases}$$

and if we choose $\epsilon > 0$ sufficiently small, then we obtain $L + CN \leq F_0 + C_\epsilon N_0$. Here taking $(\beta_1, \beta_2, \beta_3)$ as

$$\beta_2 := 16KC_1, \quad \beta_3 := 16KC_1\mathbf{R}_0^2(1 + \tan^2 \alpha), \quad \beta_1 := 16K \{ C_1(1 + \tan^2 \alpha + \mathbf{R}_0^2) + 12K\beta_3 \},$$

we see that (3.28) is equivalent to

$$48K(\beta_1 + 3\beta_3)\tan^2 \alpha < 1, \quad 12K\beta_2 \tan \alpha \sin \alpha < \mathbf{W}_1.$$

Thus there exists a small constant α_0 which depends on \mathbf{W}_1 such that (3.28) is fulfilled and we obtain the desired energy inequality. \square

Hereafter, m is an integer satisfying $m \geq 2$. We define a higher order energy and a dissipation functions E_m and F_m and a collection of the nonlinear terms N_m by

$$(3.29) \quad E_m = \sum_{k=0}^m E_0(\partial_x^k \eta, \partial_x^k \mathbf{u}^\delta), \quad F_m = \sum_{k=0}^m F_0(\partial_x^k \eta, \partial_x^k \mathbf{u}^\delta, \partial_x^k p),$$

$$(3.30) \quad N_m = \sum_{k=0}^m N_0(\partial_x^k Z) + \sum_{k=1}^m (\delta |(\mathbf{G}_k, \partial_x^k \mathbf{u}_t^\delta)_\Omega| + |(\partial_x^k \eta, \partial_x^k h_3)_\Gamma|).$$

Here, we note that $\delta |(\mathbf{G}_k, \partial_x^k \mathbf{u}_t^\delta)_\Omega|$ is the term appearing in (3.12) and that $(\eta, h_3)_\Gamma = 0$. Under an appropriate assumption of the solution, we have the following equivalence uniformly in δ .

$$\begin{aligned}
E_m &\simeq |(1 + \delta|D_x|)^2 \eta|_m^2 + \delta^2 |\eta_t|_m^2 + \delta^2 \mathbf{W} \{ |(1 + \delta|D_x|)^2 \eta_x|_m^2 + \delta^2 |\eta_{tx}|_m^2 \} \\
&\quad + \delta^2 \|(1 + |D_x|)^m v\|^2 + \delta^2 \|(1 + |D_x|)^m (1 + \delta|D_x|) \mathbf{u}_x^\delta\|^2 + \delta^2 \|(1 + |D_x|)^m \mathbf{u}_t^\delta\|^2 \\
&\simeq |\eta|_m^2 + \delta^2 \{ |(\eta_x, \eta_t)|_m^2 + \|(1 + |D_x|)^m (v, u_x, u_t)\|^2 \} \\
&\quad + \delta^4 \{ |(\eta_{xx}, \eta_{tx})|_m^2 + \|(1 + |D_x|)^m (v_x, u_{xx}, v_t)\|^2 \} + \delta^6 \|(1 + |D_x|)^m v_{xx}\|^2 \\
&\quad + \delta^2 \mathbf{W} \{ |\eta_x|_m^2 + \delta^2 |(\eta_{xx}, \eta_{tx})|_m^2 + \delta^4 |\eta_{xxx}|_m^2 \},
\end{aligned}$$

$$\begin{aligned}
F_m &\simeq \delta|\eta_x|_m^2 + (\delta^2\mathbf{W})\delta|\eta_{xx}|_m^2 + (\delta^2\mathbf{W})^2\delta|\eta_{xxx}|_m^3 + \delta\|(1+|D_x|)^m\partial_y^{-1}p_x\|^2 \\
&\quad + \delta\|(1+|D_x|)^m\mathbf{u}_x^\delta\|^2 + \delta\|(1+|D_x|)^m(1+\delta|D_x|)\nabla_\delta\mathbf{u}_x^\delta\|^2 + \delta\|(1+|D_x|)^m\nabla_\delta\mathbf{u}_t^\delta\|^2 \\
&\simeq \delta\{|\eta_x|_m^2 + \|(1+|D_x|)^m(v_y, u_x, u_{xy}, u_{ty}, \partial_y^{-1}p_x)\|^2\} \\
&\quad + \delta^3\|(1+|D_x|)^m(v_x, v_{xy}, v_{ty}, u_{xx}, u_{xxy}, u_{tx})\|^2 \\
&\quad + \delta^5\|(1+|D_x|)^m(v_{xx}, v_{xxy}, v_{tx}, u_{xxx})\|^2 + \delta^7\|(1+|D_x|)^mv_{xxx}\|^2 \\
&\quad + (\delta^2\mathbf{W})\delta|\eta_{xx}|_m^2 + (\delta^2\mathbf{W})^2\delta|\eta_{xxx}|_m^2.
\end{aligned}$$

Applying ∂_x^k to (2.28)–(2.30), using Proposition 3.6, and adding the resulting inequalities for $0 \leq k \leq m$, we obtain a higher order energy estimate

$$(3.31) \quad \frac{d}{dt}E_m + F_m \leq C_2N_m.$$

4 Estimate for the pressure

We will use an elliptic estimate for the pressure p . First, we derive an equation for p . Applying $\nabla_\delta \cdot$ to the first equation in (2.1) and using the second equation in (2.1), we have

$$\begin{aligned}
\frac{2}{\mathbf{R}}\Delta_\delta p &= -\{\varepsilon(\delta u_x)^2 + 2\delta^2v_x(\varepsilon u_y + \bar{u}_y) + \varepsilon(\delta v_y)^2\} \\
&= -\varepsilon^{-1}\text{tr}(\nabla_\delta(\varepsilon\mathbf{u}^\delta + \mathbf{U})^\text{T})^2 =: f.
\end{aligned}$$

We transform this by the diffeomorphism Φ introduced by (2.4) and obtain

$$(4.1) \quad \nabla_\delta \cdot A_6 \nabla_\delta p' = \frac{1}{2}\mathbf{R}J(f \circ \Phi) =: g,$$

where $p' = p \circ \Phi$ and $A_6 = JA_2^\text{T}A_2$. On the other hand, by the definition of f and (2.10), we have $f \circ \Phi = -\varepsilon^{-1}\text{tr}((A_2\nabla_\delta)(\varepsilon A_1\mathbf{u}^{\delta'} + \mathbf{U}')^\text{T})^2$, where $\mathbf{u}^{\delta'}$ is defined by (2.10) and $\mathbf{U}' = (U', 0)^\text{T} := \mathbf{U} \circ \Phi$. Here we see that

$$(A_2\nabla_\delta)(\varepsilon A_1\mathbf{u}^{\delta'} + \mathbf{U}')^\text{T} = \begin{pmatrix} \delta\partial_x + a_1\partial_y \\ J^{-1}\partial_y \end{pmatrix} (\varepsilon J^{-1}u' + U', -\varepsilon a_1u' + \varepsilon\delta v') = \varepsilon F_1 u'_y + F_2,$$

where

$$\begin{aligned}
F_1 &:= \begin{pmatrix} a_1J^{-1} & -a_1^2 \\ J^{-2} & -a_1J^{-1} \end{pmatrix}, \\
F_2 &:= \begin{pmatrix} \delta(\varepsilon J^{-1}u')_x + \varepsilon a_1(J^{-1})_y u' & \varepsilon\delta(-a_1u' + \delta v')_x - \varepsilon a_1 a_{1y}u' + \varepsilon\delta a_1 v'_y \\ \varepsilon J^{-1}(J^{-1})_y u' + J^{-1}U'_y & -\varepsilon J^{-1}a_{1y}u' + \varepsilon\delta J^{-1}v'_y \end{pmatrix}.
\end{aligned}$$

Here, in the above calculation, we used the identity $\delta U'_x + a_1 U'_y = 0$. It follows from $F_1^2 = O$ that

$$(4.2) \quad g = -\frac{1}{2}\mathbf{R}J\{\text{tr}(F_1F_2 + F_2F_1)u'_y + \varepsilon^{-1}\text{tr}(F_2^2)\},$$

where F_1 and F_2 do not contain u'_y .

Next, as for the boundary condition on Γ , by the second equation in (2.29), we obtain

$$(4.3) \quad p' = -\delta u'_x + \frac{1}{\tan\alpha}\eta - \frac{\delta^2\mathbf{W}}{\sin\alpha}\eta_{xx} + h_2 =: \phi' \quad \text{on } \Gamma.$$

Moreover, as for the boundary condition on Σ , taking the trace of the second component of the first equation in (2.1) on Σ , we obtain $(p + \frac{1}{2}u_x)_y = 0$ on Σ . In view of (2.10) and (2.12), this is transformed into

$$J^{-1} \left\{ p' + \frac{\delta}{2}(J^{-1}u')_x + \frac{1}{2}a_1(J^{-1}u')_y \right\}_y = 0 \quad \text{on } \Sigma.$$

Recalling $a_1 = -yJ^{-1}\varepsilon\delta\tilde{\eta}_x$, $J = 1 + \varepsilon(y\tilde{\eta})_y$, and (2.6), we have $a_1|_{y=0} = 0$, $a_{1yy}|_{y=0} = 0$, and $J_y|_{y=0} = 0$, so that we obtain $(a_1(J^{-1}u')_y)|_{y=0} = (J^{-1}a_{1y}u')|_{y=0}$. Therefore we have

$$(4.4) \quad (p' + g_0)_y = 0 \quad \text{on } \Sigma,$$

where

$$(4.5) \quad g_0 = \frac{1}{2} \{ \delta(J^{-1}u')_x + J^{-1}a_{1y}u' \}.$$

Summarizing (4.1), (4.3), and (4.4), we have

$$(4.6) \quad \begin{cases} \nabla_\delta \cdot A_6 \nabla_\delta p = g & \text{in } \Omega, \\ p = \phi & \text{on } \Gamma, \\ (p + g_0)_y = 0 & \text{on } \Sigma. \end{cases}$$

Here we dropped the prime sign in the notation.

We proceed to derive an elliptic estimate for p . To this end, we will consider the following boundary value problem

$$(4.7) \quad \begin{cases} \Delta_\delta q = g + \nabla_\delta \cdot \mathbf{g} & \text{in } \Omega, \\ q = \psi_1 & \text{on } \Gamma, \\ q_y = 0 & \text{on } \Sigma, \end{cases}$$

and show the following lemma.

Lemma 4.1. *For any $g, \mathbf{g} \in L^2(\Omega)$ and $\psi_1 \in H^{\frac{1}{2}}(\Gamma)$, there exists a unique solution $q \in H^1(\Omega)$ of (4.7) satisfying*

$$\|\nabla_\delta q\|^2 \lesssim \|g\|^2 + \|\mathbf{g}\|^2 + \delta \|D_x\|^{\frac{1}{2}} \psi_1|_0^2.$$

Proof. First, we will construct a solution of the following equation

$$(4.8) \quad \Delta_\delta q_1 = g + \nabla_\delta \cdot \mathbf{g} \quad \text{in } \Omega.$$

We extend g and $g_1 := \mathbf{g} \cdot \mathbf{e}_1$ as even and 4-periodic functions in y satisfying $\int_0^4 g(x, y) dy = \int_0^4 g_1(x, y) dy = 0$ and $g_2 := \mathbf{g} \cdot \mathbf{e}_2$ as an odd and 4-periodic function. By these extension and Fourier series expansion in x and y , we can construct a solution of (4.8) satisfying

$$(4.9) \quad q_{1y}(x, 0) = 0,$$

$$(4.10) \quad \|q_1\|^2 + \|\nabla_\delta q_1\|^2 \lesssim \|g\|^2 + \|\mathbf{g}\|^2.$$

Next, let us seek the solution of (4.7) in the form $q = q_1 + q_2$, where q_2 should be the solution of the following boundary value problem

$$\begin{cases} \Delta_\delta q_2 = 0 & \text{in } \Omega, \\ q_2 = \psi_2 & \text{on } \Gamma, \\ q_{2y} = 0 & \text{on } \Sigma, \end{cases}$$

where $\psi_2 = \psi_1 - q_1|_{y=1}$ and we used (4.9). By Fourier series expansion in x , we easily construct a solution of the above problem satisfying

$$(4.11) \quad \|\nabla_\delta q_2\|^2 \lesssim \delta \|D_x|^{1/2} \psi_2|_0^2.$$

Here, Lemma 3.2 yields $\delta \|D_x|^{1/2} q_1|_0^2 \lesssim \|q_1\|^2 + \|\nabla_\delta q_1\|^2$, which together with (4.10) and (4.11) implies the desired estimate. The uniqueness of the solution is well-known, so that the proof is complete. \square

Now, we rewrite (4.6) as

$$(4.12) \quad \begin{cases} \Delta_\delta q = g + \nabla_\delta \cdot (\nabla_\delta g_0 - N_6 \nabla_\delta p) & \text{in } \Omega, \\ q = \phi + g_0 & \text{on } \Gamma, \\ q_y = 0 & \text{on } \Sigma, \end{cases}$$

where $q = p + g_0$ and N_6 is a nonlinear part of A_6 , that is, $A_6 = I + N_6$. Applying Lemma 4.1 to the above boundary value problem, we have

$$(4.13) \quad \|\nabla_\delta p\|^2 \lesssim \|g\|^2 + \|g_0\|^2 + \|\nabla_\delta g_0\|^2 + \|N_6 \nabla_\delta p\|^2 + \delta \|D_x|^{1/2} \phi|_0^2,$$

where we used $\delta \|D_x|^{1/2} g_0|_0^2 \lesssim \|g_0\|^2 + \|\nabla_\delta g_0\|^2$ which comes from Lemma 3.2. Differentiating (4.12) in x and t , likewise we deduce

$$(4.14) \quad \begin{cases} \delta \|\nabla_\delta p_x\|^2 \lesssim \delta \|g_x\|^2 + \delta \|g_{0x}\|^2 + \delta \|\nabla_\delta g_{0x}\|^2 + \delta \|(N_6 \nabla_\delta p)_x\|^2 + \delta^2 \|D_x|^{1/2} \phi_x|_0^2, \\ \delta \|\nabla_\delta p_t\|^2 \lesssim \delta \|g_t\|^2 + \delta \|g_{0t}\|^2 + \delta \|\nabla_\delta g_{0t}\|^2 + \delta \|(N_6 \nabla_\delta p)_t\|^2 + \delta^2 \|D_x|^{1/2} \phi_t|_0^2. \end{cases}$$

Here, for the same reason as the modification of the lowest order energy, we need to modify (4.13), that is, we estimate $\delta^{-1} \|\nabla_\delta p\|^2$ in a different way. As for $\delta^{-1} \|p_y\|^2$, by using the second component of the first equation in (2.28), we see that

$$(4.15) \quad \delta^{-1} \|p_y\|^2 \lesssim F_0 + \delta^{-1} \|f_1\|^2,$$

where f_1 is defined by (3.16). To estimate $\delta \|p_x\|^2$ in terms of the dissipation function F_0 , we use the term $\delta \|\partial_y^{-1} p_x\|^2$ in the following way. We compute

$$\begin{aligned} \delta \|p_x\|^2 &= \delta \iint_\Omega p_x(x, y) \left(\frac{\partial}{\partial y} \int_0^y p_x(x, z) dz \right) dx dy \\ &= -\delta \iint_\Omega p_{xy}(x, y) \left(\int_0^y p_x(x, z) dz \right) dx dy + \delta \int_0^1 p_x(x, 1) \left(\int_0^1 p_x(x, z) dz \right) dx \\ &\leq \delta \|p_{xy}\| (\|p_x\| + \|\partial_y^{-1} p_x\|) + \delta |p_x|_0 \|p_x\| \end{aligned}$$

so that we have

$$(4.16) \quad \delta \|p_x\|^2 \lesssim \delta \|p_{xy}\|^2 + \delta \|\partial_y^{-1} p_x\|^2 + |p_x|_0^2$$

Here, it follows from the second equation in (2.29) that $\delta |p_x|_0^2 \lesssim F_0 + \delta |h_{2x}|_0^2$. This together with (4.15) and (4.16) yields

$$\delta^{-1} \|\nabla_\delta p\|^2 \lesssim F_0 + \delta \|p_{xy}\|^2 + \delta |h_{2x}|_0^2 + \delta^{-1} \|f_1\|^2.$$

This is the modified estimate of $\delta^{-1} \|\nabla_\delta p\|^2$.

By differentiating (4.12) with respect to x and applying the above argument and (4.14), we obtain the following lemma.

Lemma 4.2. For $0 \leq k \leq m$ and $1 \leq l \leq m$, we have

$$(4.17) \quad \delta^{-1} \|\nabla_\delta \partial_x^k p\|^2 \lesssim F_m + \delta \|\partial_x^k p_{xy}\|^2 + \delta |\partial_x^k h_{2x}|_0^2 + \delta^{-1} \|\partial_x^k f_1\|^2,$$

$$(4.18) \quad \delta \|\nabla_\delta \partial_x^k p_x\|^2 \lesssim \delta \|\partial_x^k g_x\|^2 + \delta \|\partial_x^k g_{0x}\|^2 + \delta \|\nabla_\delta \partial_x^k g_{0x}\|^2 \\ + \delta \|\partial_x^k (N_6 \nabla_\delta p)_x\|^2 + \delta^2 |D_x|^{k+\frac{1}{2}} \phi_x|_0^2,$$

$$(4.19) \quad \delta \|\nabla_\delta \partial_x^{l-1} p_t\|^2 \lesssim \delta \|\partial_x^{l-1} g_t\|^2 + \delta \|\partial_x^{l-1} g_{0t}\|^2 + \delta \|\nabla_\delta \partial_x^{l-1} g_{0t}\|^2 \\ + \delta \|\partial_x^{l-1} (N_6 \nabla_\delta p)_t\|^2 + \delta^2 |D_x|^{l-\frac{1}{2}} \phi_t|_0^2.$$

5 Estimate for nonlinear terms

We modify the energy and the dissipation functions E_m and F_m defined by (3.29) as

$$(5.1) \quad \tilde{E}_m = E_m + \|(1 + |D_x|)^m u\|^2 + \|(1 + |D_x|)^m u_y\|^2,$$

$$(5.2) \quad \tilde{F}_m = F_m + \delta \|(1 + \delta |D_x|)^{\frac{5}{2}} \eta_t|_m^2 + (\delta^2 \mathbb{W})^2 \delta^2 |D_x|^{\frac{7}{2}} \eta|_m^2 \\ + \delta^{-1} \|(1 + |D_x|)^m (1 + \delta |D_x|) \nabla_\delta p\|^2 + \delta \|(1 + |D_x|)^{m-1} \nabla_\delta p_t\|^2.$$

We also introduce another energy function D_m by

$$(5.3) \quad D_m = \|(1 + \delta |D_x|)^2 \eta|_m^2 + \|(1 + |D_x|)^m \mathbf{u}^\delta\|^2 + \|(1 + |D_x|)^m D_\delta \mathbf{u}^\delta\|^2 \\ + \|(1 + |D_x|)^m D_\delta^2 \mathbf{u}^\delta\|^2 + (\delta^2 \mathbb{W})^2 \|(1 + \delta |D_x|) \eta_x|_{m+1}^2 + (\delta^2 \mathbb{W}) \delta^2 \|(1 + |D_x|)^m v_{xy}\|^2,$$

which does not include any time derivatives. Moreover, we have the following equivalence uniformly in δ .

$$D_m \simeq |\eta|_m^2 + \|(1 + |D_x|)^m (u, u_y, u_{yy})\|^2 \\ + \delta^2 \{ |\eta_x|_m^2 + \|(1 + |D_x|)^m (v, v_y, u_x, u_{xy}, v_{yy})\|^2 \} \\ + \delta^4 \{ |\eta_{xx}|_m^2 + \|(1 + |D_x|)^m (v_x, v_{xy}, u_{xx})\|^2 \} \\ + \delta^6 \{ |\eta_{xxx}|_m^2 + \|(1 + |D_x|)^m v_{xx}\|^2 \} \\ + \delta^2 \mathbb{W} \{ |\eta_x|_m^2 + \delta^2 |\eta_{xx}|_m^2 + \delta^4 |\eta_{xxx}|_m^2 + \delta^2 \|(1 + |D_x|)^m v_{xy}\|^2 \} \\ + (\delta^2 \mathbb{W})^2 \{ |\eta_{xx}|_m^2 + \delta^2 |\eta_{xxx}|_m^2 \}.$$

Since the proof of nonlinear estimates derived in this section is particular long, we give a guiding principle of the proof. A goal of Section 5 is to estimate the nonlinear terms in terms of $\tilde{E}_2 \tilde{F}_m$, $\tilde{F}_2 \tilde{E}_m$, and $D_2 D_m$. As for $\tilde{E}_2 \tilde{F}_m$, by using a smallness of the energy this term can be absorbed in the right-hand side of the energy inequality (3.31). As for $\tilde{F}_2 \tilde{E}_m$, using a boundedness of $\int_0^t \tilde{F}_2(\tau) d\tau$ and a standard Gronwall's inequality we can estimate this term. As for $D_2 D_m$, we use this estimate in order to estimate an initial energy $E(0)$. Here, what we should be careful is that if we use the Sobolev embedding theorem in Ω , that is, $\|u\|_{L^\infty} \lesssim \|u\|_{H^2}$ and Poincaré's inequality for η , that is, $|\eta|_{L^\infty} \lesssim |\eta_x|_0$, we cannot obtain uniform estimates in δ . Therefore, we have to estimate nonlinear terms carefully with fundamental inequalities which are described below.

Lemma 5.1. If $f(x, 0) = 0$, then we have

$$\|f\|_{L^\infty} \lesssim \|f_y\| + \|f_{xy}\|.$$

Proof. By the Sobolev embedding theorem, we see that

$$\begin{aligned} |f(x, y)|^2 &= |f(x, y) - f(x, 0)|^2 = \left| \int_0^y f_y(x, y) dy \right|^2 \\ &\leq \int_0^1 |f_y(x, y)|^2 dy \lesssim \int_0^1 (\|f_y(\cdot, y)\|_{L^2(\mathbb{G})}^2 + \|f_{xy}(\cdot, y)\|_{L^2(\mathbb{G})}^2) dy, \end{aligned}$$

which is the desired inequality. \square

Lemma 5.2. *For any integer $k \geq 0$, we have*

$$\begin{aligned} \|\partial_x^k(af)\| &\lesssim \|a\|_{L^\infty} \|\partial_x^k f\| + (\|\partial_x^k a\| + \|\partial_x^k a_y\|)(\|f\| + \|f_x\|), \\ \|\partial_x^k(abf)\| &\lesssim \|a\|_{L^\infty} \|b\|_{L^\infty} \|\partial_x^k f\| + \|b\|_{L^\infty} (\|\partial_x^k a\| + \|\partial_x^k a_y\|)(\|f\| + \|f_x\|) \\ &\quad + \|a\|_{L^\infty} (\|\partial_x^k b\| + \|\partial_x^k b_y\|)(\|f\| + \|f_x\|). \end{aligned}$$

Proof. By the well-known inequality

$$\|\partial_x^k(af)(\cdot, y)\|_{L^2(\mathbb{G})} \lesssim \|a(\cdot, y)\|_{L^\infty(\mathbb{G})} \|\partial_x^k f(\cdot, y)\|_{L^2(\mathbb{G})} + \|f(\cdot, y)\|_{L^\infty(\mathbb{G})} \|\partial_x^k a(\cdot, y)\|_{L^2(\mathbb{G})},$$

and the Sobolev embedding theorem, we see that

$$\begin{aligned} \|\partial_x^k(af)\|^2 &\lesssim \int_0^1 (\|a(\cdot, y)\|_{L^\infty(\mathbb{G})}^2 \|\partial_x^k f(\cdot, y)\|_{L^2(\mathbb{G})}^2 + \|f(\cdot, y)\|_{L^\infty(\mathbb{G})}^2 \|\partial_x^k a(\cdot, y)\|_{L^2(\mathbb{G})}^2) dy \\ &\lesssim \|a\|_{L^\infty}^2 \|\partial_x^k f\|^2 + \sup_{y \in (0,1)} \|\partial_x^k a(\cdot, y)\|_{L^2(\mathbb{G})}^2 \int_0^1 \|f(\cdot, y)\|_{L^\infty(\mathbb{G})}^2 dy \\ &\lesssim \|a\|_{L^\infty}^2 \|\partial_x^k f\|^2 + (\|\partial_x^k a\|^2 + \|\partial_x^k a_y\|^2)(\|f\|^2 + \|f_x\|^2). \end{aligned}$$

We can prove the second inequality in a similar way. \square

Lemma 5.3. *For any integer $k \geq 1$, we have*

$$\|[\partial_x^k, a]f\| \lesssim \|a_x\|_{L^\infty} \|\partial_x^{k-1} f\| + (\|\partial_x^k a\| + \|\partial_x^k a_y\|)(\|f\| + \|f_x\|).$$

Proof. In view of the well-known inequality

$$\|[\partial_x^k, a]f(\cdot, y)\|_{L^2(\mathbb{G})} \lesssim \|a(\cdot, y)\|_{L^\infty(\mathbb{G})} \|\partial_x^{k-1} f(\cdot, y)\|_{L^2(\mathbb{G})} + \|f(\cdot, y)\|_{L^\infty(\mathbb{G})} \|\partial_x^k a(\cdot, y)\|_{L^2(\mathbb{G})},$$

the desired inequality follows in a similar way as the proof of Lemma 5.2. \square

Throughout this section, we assume that

$$(5.4) \quad \tilde{E}_2(t) \leq c_1 \quad \text{for } t \in [0, T/\varepsilon],$$

where T and c_1 will be determine later. We also assume that (η, u, v, p) is a solution of (2.28)–(2.30), $0 < \delta, \varepsilon \leq 1$, $W_1 \leq W \leq \delta^{-2}W_2$, k and l are integers satisfying $0 \leq k \leq m$ and $1 \leq l \leq m$. Moreover, we will generally denote smooth functions of \mathbf{f} by the same symbol $\Phi = \Phi(\mathbf{f})$ and Φ_0 is such a function satisfying $\Phi_0(\mathbf{0}) = 0$. We also use such a function Φ_0 depending also on $y \in [0, 1]$ and denote it by $\Phi_0(\mathbf{f}; y)$, that is, $\Phi_0(\mathbf{0}; y) \equiv 0$.

We prepare several lemmas to proceed nonlinear estimates.

Lemma 5.4. *The following estimates hold.*

$$(5.5) \quad \|\tilde{\eta}\|_{L^\infty}^2 \lesssim \min\{\tilde{E}_2, D_2\}, \quad \|D_\delta^i \tilde{\eta}\|_{L^\infty}^2 \lesssim \min\{\delta^2 \tilde{E}_2, \delta^2 D_2, \delta \tilde{F}_2\} \quad \text{for } 1 \leq i \leq 4,$$

$$(5.6) \quad \delta^2 \mathbf{W} \|D_\delta^i \tilde{\eta}_x\|_{L^\infty}^2 + \delta^4 \mathbf{W} \|D_\delta^i \tilde{\eta}_{xx}\|_{L^\infty}^2 \lesssim \min\{\tilde{E}_2, D_2, \delta \tilde{F}_2\} \quad \text{for } i = 0, 1,$$

$$(5.7) \quad \begin{cases} \|\partial_x^i \mathbf{u}^\delta\|_{L^\infty}^2 \lesssim \min\{\tilde{E}_2, D_2\}, & \delta \|\partial_x^i \mathbf{u}_x^\delta\|_{L^\infty}^2 + \delta \|\partial_x^i \mathbf{u}_t^\delta\|_{L^\infty}^2 \lesssim \tilde{F}_2 \quad \text{for } i = 0, 1, \\ \delta^4 \|v_{xx}\|_{L^\infty}^2 \lesssim \min\{\tilde{E}_2, D_2\}, \end{cases}$$

$$(5.8) \quad \begin{cases} \|\tilde{\eta}_t\|_{L^\infty}^2 \lesssim \min\{\tilde{E}_2, D_2\}, & \delta \|\tilde{\eta}_t\|_{L^\infty}^2 \lesssim \tilde{F}_2, \\ \|D_\delta^i \tilde{\eta}_t\|_{L^\infty}^2 \lesssim \min\{\tilde{E}_2, D_2, \delta \tilde{F}_2\} \quad \text{for } i = 1, 2, & \|D_\delta^3 \tilde{\eta}_t\|_{L^\infty}^2 \lesssim \delta \tilde{F}_2, \end{cases}$$

$$(5.9) \quad \delta \|D_\delta^i \tilde{\eta}_{tt}\|_{L^\infty}^2 \lesssim \tilde{F}_2, \quad \text{for } i = 0, 1.$$

In particular, we have

$$(5.10) \quad \begin{cases} \|(\tilde{\eta}, \tilde{\eta}_t, D_\delta \tilde{\eta}_t, D_\delta^2 \tilde{\eta}_t, \mathbf{u}^\delta, \mathbf{u}_x^\delta)\|_{L^\infty}^2 \lesssim \min\{\tilde{E}_2, D_2\}, \\ \|(D_\delta \tilde{\eta}, D_\delta^2 \tilde{\eta}, D_\delta^3 \tilde{\eta})\|_{L^\infty}^2 \lesssim \delta \min\{\tilde{E}_2, D_2\}. \end{cases}$$

Remark 5.1. Using (5.5) and taking c_1 sufficiently small, we see that $J = 1 + \varepsilon(y\tilde{\eta})_y$ and $I - A_5$ are positive definite.

Proof. By (2.8) in Lemma 2.1, we have

$$\begin{aligned} \|\tilde{\eta}\|_{L^\infty}^2 &\lesssim |\eta|_1^2 \lesssim \min\{\tilde{E}_2, D_2\} \\ \|D_\delta^i \tilde{\eta}\|_{L^\infty}^2 &\lesssim \delta^{2i} |\partial_x^i \eta|_1^2 \lesssim \min\{\delta^2 \tilde{E}_2, \delta^2 D_2, \delta \tilde{F}_2\} \quad \text{for } 1 \leq i \leq 4. \end{aligned}$$

Thus (5.5) holds. Similarly, we obtain (5.6). (5.7) is obtained from Lemma 5.1 and the second equation in (2.28). By the second equation in (2.28), we have $|v|_1 \lesssim \|(1 + |D_x|)v_y\| = \|(1 + |D_x|)u_x\|$. In view of the assumption (5.4), we have

$$|\partial_x^j h_3|_0 \lesssim \varepsilon^2 |\eta|_{L^\infty}^2 |\partial_x^{j+1} \eta|_0 \lesssim |\partial_x^{j+1} \eta|_0 \quad \text{for } j \geq 0.$$

Therefore, by (2.8) in Lemma 2.1 and the third equation in (2.29), we see that

$$\begin{aligned} \|\tilde{\eta}_t\|_{L^\infty} &\lesssim |\eta_t|_1 \lesssim |v|_1 + |\eta_x|_1 + |h_3|_1 \lesssim \|(1 + |D_x|)u_x\| + |\eta_x|_1, \\ \|D_\delta^i \tilde{\eta}_t\|_{L^\infty} &\lesssim \delta^i |\partial_x^i \eta_t|_1 \lesssim \delta^i (|\partial_x^i v|_1 + |\partial_x^{i+1} \eta|_1 + |\partial_x^i h_3|_1) \lesssim \delta^i (\|(1 + |D_x|)\partial_x^{i+1} u\| + |\partial_x^{i+1} \eta|_1). \end{aligned}$$

These estimates give (5.8). Similarly, we see that

$$\begin{aligned} \|\tilde{\eta}_{tt}\|_{L^\infty} &\lesssim |\eta_{tt}|_1 \lesssim |v_t|_1 + |\eta_{tx}|_1 + |h_{3t}|_1 \lesssim \|(1 + |D_x|)u_{tx}\| + |\eta_t|_2, \\ \|D_\delta \tilde{\eta}_{tt}\|_{L^\infty} &\lesssim \delta |\partial_x \eta_{tt}|_1 \lesssim \delta (|\partial_x v_t|_1 + |\partial_x^2 \eta_t|_1 + |\partial_x h_{3t}|_1) \lesssim \delta (\|(1 + |D_x|)\partial_x u_{tx}\| + |\eta_{tx}|_2 + |\eta_x|_2). \end{aligned}$$

Here, we used $|\eta_t|_{L^\infty} \leq \|\tilde{\eta}_t\|_{L^\infty} \lesssim \sqrt{\tilde{E}_2}$ and the assumption (5.4). Thus (5.9) holds. The proof is complete. \square

Lemma 5.5. *The following estimates hold.*

$$(5.11) \quad \|\partial_x^k \tilde{\eta}\|^2 \lesssim \min\{\tilde{E}_m, D_m\}, \quad \|\partial_x^k D_\delta^i \tilde{\eta}\|^2 \lesssim \min\{\tilde{E}_m, D_m, \delta \tilde{F}_m\} \quad \text{for } i = 1, 2, 3,$$

$$(5.12) \quad \delta^2 \mathbf{W} \|\partial_x^k D_\delta^i \tilde{\eta}_x\|^2 \lesssim \min\{\tilde{E}_m, D_m\} \quad \text{for } i = 1, 2,$$

$$(5.13) \quad \|\partial_x^k D_\delta^4 \tilde{\eta}\|^2 \lesssim \delta \tilde{F}_m,$$

$$(5.14) \quad \delta^2 \|\partial_x^k D_\delta^i \tilde{\eta}_t\|^2 \lesssim \min\{\tilde{E}_m, D_m, \delta \tilde{F}_m\} \quad \text{for } i = 0, 1, 2, \quad \delta \|\partial_x^k D_\delta^3 \tilde{\eta}_t\|^2 \lesssim \tilde{F}_m,$$

$$(5.15) \quad \delta^3 \|\partial_x^k D_\delta^i \tilde{\eta}_{tt}\|^2 \lesssim \tilde{F}_m \quad \text{for } i = 0, 1.$$

Proof. By (2.7) and (2.9) in Lemma 2.1, we have

$$\begin{aligned}\|\partial_x^k D_\delta^i \tilde{\eta}\| &\lesssim \delta^i |\partial_x^{k+i} \eta|_0 \quad \text{for } i \geq 0, \\ \|\partial_x^k D_\delta^4 \tilde{\eta}\| &\lesssim \delta^{\frac{7}{2}} \| |D_x|^{k+\frac{7}{2}} \eta \|_0,\end{aligned}$$

which give (5.11) and (5.13), respectively. Similarly, we obtain (5.12). By (2.7) in Lemma 2.1 and a similar argument in the proof of Lemma 5.4, we see that

$$\begin{aligned}\|\partial_x^k D_\delta^i \tilde{\eta}_t\| &\lesssim \delta^i |\partial_x^{k+i} \eta_t|_0 \lesssim \delta^i (\|\partial_x^{k+i+1} u\| + |\partial_x^{k+i+1} \eta|_0) \\ &\lesssim \delta^i (\|(1 + |D_x|)^m \partial_x^{i+1} u\| + |\partial_x^{i+1} \eta|_m).\end{aligned}$$

By (2.9) in Lemma 2.1, Lemma 3.2, Poincaré's inequality, and the estimate

$$(5.16) \quad \| |D_x|^{k+\frac{5}{2}} h_3 \|_0 \lesssim |(\eta, \eta_x)|_{L^\infty}^2 \| |D_x|^{k+\frac{7}{2}} \eta \|_0 \lesssim \| |D_x|^{k+\frac{7}{2}} \eta \|_0,$$

we see that

$$\begin{aligned}\|\partial_x^k D_\delta^3 \tilde{\eta}_t\| &\lesssim \delta^{\frac{5}{2}} \| |D_x|^{\frac{1}{2}} \partial_x^{k+2} \eta_t \|_0 \leq \delta^{\frac{5}{2}} (\| |D_x|^{\frac{1}{2}} \partial_x^{k+2} v \|_0 + \| |D_x|^{\frac{1}{2}} \partial_x^{k+2} \eta_x \|_0 + \| |D_x|^{\frac{1}{2}} \partial_x^{k+2} h_3 \|_0) \\ &\lesssim \delta^3 \|\partial_x^k v_{xxx}\| + \delta^2 \|\partial_x^k v_{xxy}\| + \delta^{\frac{5}{2}} \| |D_x|^{k+\frac{7}{2}} \eta \|_0 \\ &\lesssim \delta^3 \|(1 + |D_x|)^m v_{xxx}\| + \delta^2 \|(1 + |D_x|)^m v_{xxy}\| + \delta^{\frac{5}{2}} \| |D_x|^{k+\frac{7}{2}} \eta \|_0.\end{aligned}$$

These estimates give (5.14). It is easy to see that

$$|\partial_x^j h_{3t}|_0 \lesssim \varepsilon^2 (|\eta|_{L^\infty}^2 |\partial_x^{j+1} \eta_t|_0 + |\eta|_{L^\infty} |\eta_t|_{L^\infty} |\partial_x^{j+1} \eta|_0) \lesssim |\partial_x^{j+1} \eta_t|_0 + |\partial_x^{j+1} \eta|_0 \quad \text{for } j \geq 0.$$

Therefore, by (2.7) in Lemma 2.1 and the third equation in (2.29), we see that

$$\begin{aligned}\|\partial_x^k \tilde{\eta}_{tt}\| &\lesssim |\partial_x^k \eta_{tt}|_0 \lesssim \|(1 + |D_x|)^m u_{tx}\|_0 + |\eta_{tx}|_m + |h_{3t}|_m \\ &\lesssim \|(1 + |D_x|)^m u_{tx}\|_0 + |\eta_{tx}|_m + |\eta_x|_m.\end{aligned}$$

Similarly, by (2.9) in Lemma 2.1 we obtain

$$\begin{aligned}\|\partial_x^k D_\delta \tilde{\eta}_{tt}\| &\lesssim \delta^{\frac{1}{2}} \| |D_x|^{\frac{1}{2}} \partial_x^k \eta_{tt} \|_0 \lesssim \delta^{\frac{1}{2}} (\| |D_x|^{\frac{1}{2}} \partial_x^k v_t \|_0 + \| |D_x|^{\frac{1}{2}} \partial_x^{k+1} \eta_t \|_0 + \| |D_x|^{\frac{1}{2}} \partial_x^k h_{3t} \|_0) \\ &\lesssim \delta \|\partial_x^k v_{tx}\| + \|\partial_x^k v_{ty}\| + \delta \|\partial_x^k \eta_{txx}\|_0 + |\partial_x^k \eta_{tx}|_0 + \delta |\partial_x^{k+1} h_{3t}|_0 + |\partial_x^k h_{3t}|_0 \\ &\lesssim \delta \|(1 + |D_x|)^m v_{tx}\| + \|(1 + |D_x|)^m v_{ty}\| + \delta |\eta_{txx}|_m + |(\eta_{xx}, \eta_{tx}, \eta_x)|_m.\end{aligned}$$

These estimates give (5.15). The proof is complete. \square

Lemma 5.6. *The following estimates hold.*

$$(5.17) \quad \delta^{2i+1} \| |D_x|^{i+\frac{1}{2}} \eta \|_m^2 \lesssim \min\{\tilde{E}_m, D_m\}, \quad \delta^{2i+2} \| |D_x|^{i+\frac{1}{2}} \eta_x \|_m^2 \lesssim \tilde{F}_m \quad \text{for } i = 0, 1, 2,$$

$$(5.18) \quad \delta^3 \mathbf{W} \| |D_x|^{\frac{1}{2}} \eta_x \|_m^2 \lesssim \min\{\tilde{E}_m, D_m\}, \quad \delta^{2i+4} \mathbf{W} \| |D_x|^{i+\frac{1}{2}} \eta_{xx} \|_m^2 \lesssim \tilde{F}_m \quad \text{for } i = 0, 1,$$

$$(5.19) \quad \delta |\mathbf{u}^\delta|_{m+\frac{1}{2}}^2 \lesssim \min\{\tilde{E}_m, D_m\}, \quad \delta^3 |\mathbf{u}_x^\delta|_{m+\frac{1}{2}}^2 \lesssim \min\{D_m, \delta \tilde{F}_m\}, \quad \delta^5 |\mathbf{u}_{xx}^\delta|_{m+\frac{1}{2}}^2 \lesssim \delta \tilde{F}_m,$$

$$(5.20) \quad |\mathbf{u}^\delta|_m^2 \lesssim \min\{\tilde{E}_m, D_m\}, \quad \delta^{2i} |\partial_x^i \mathbf{u}^\delta|_m^2 \lesssim \delta \tilde{F}_m \quad \text{for } i = 1, 2,$$

$$(5.21) \quad \delta^2 |\mathbf{u}_t^\delta|_{m+\frac{1}{2}}^2 \lesssim \tilde{F}_m.$$

Proof. By an interpolation inequality, we have $\delta^{2i+1}||D_x|^{i+\frac{1}{2}}\eta|_m^2 \lesssim \delta^{2i}|\partial_x^i\eta|_m^2 + \delta^{2i+2}|\partial_x^i\eta_x|_m^2$, which gives the first estimate in (5.17). Similarly, we can show the second estimate in (5.17) for $i = 0, 1$, and the case $i = 2$ follows directly from the definition of \tilde{F}_m . Likewise, we obtain (5.18). By Lemma 3.2 and Poincaré's inequality, we see that

$$\begin{aligned} \delta^{2i+1}|\partial_x^i\mathbf{u}^\delta|_{m+\frac{1}{2}}^2 &\lesssim \delta^{2i+1}|\partial_x^i\mathbf{u}^\delta|_0^2 + \delta^{2i+1}||D_x|^{\frac{1}{2}}\partial_x^{m+i}\mathbf{u}^\delta|_0^2 \\ &\lesssim \delta^{2i+1}\|\partial_x^i\mathbf{u}_y^\delta\|^2 + \delta^{2(i+1)}\|\partial_x^{m+i}\mathbf{u}_x^\delta\|^2 + \delta^{2i}\|\partial_x^{m+i}\mathbf{u}_y^\delta\|^2 \end{aligned}$$

for $i \geq 0$, which leads to (5.19). Similarly, we can show (5.21). Poincaré's inequality and the second equation in (2.28) yield (5.20). The proof is complete. \square

In view of Lemmas 5.4 and 5.5 and the inequality $\|\partial_x^k\Phi_0(\mathbf{f}; y)\| \leq C(\|\mathbf{f}\|_{L^\infty})\|\partial_x^k\mathbf{f}\|$, we obtain the following lemma.

Lemma 5.7. *For $j = 0, 1$, the following estimates hold.*

$$(5.22) \quad \|\Phi_0(\tilde{\eta}, D_\delta\tilde{\eta}, D_\delta^2\tilde{\eta}, D_\delta^3\tilde{\eta}, \delta\tilde{\eta}_t, \delta D_\delta\tilde{\eta}_t, \delta D_\delta^2\tilde{\eta}_t, \mathbf{u}^\delta, \delta\mathbf{u}_x^\delta, \delta^3v_{xx}; y)\|_{L^\infty}^2 \lesssim \min\{\tilde{E}_2, D_2\},$$

$$(5.23) \quad \|\partial_x^k\Phi_0(\tilde{\eta}, D_\delta\tilde{\eta}, D_\delta^2\tilde{\eta}, D_\delta^3\tilde{\eta}, \delta\tilde{\eta}_t, \delta D_\delta\tilde{\eta}_t, \delta D_\delta^2\tilde{\eta}_t, \mathbf{u}^\delta, \delta\mathbf{u}_x^\delta, \delta^3v_{xx}; y)\|^2 \lesssim \min\{\tilde{E}_m, D_m\},$$

$$(5.24) \quad \|\partial_x^k\partial_y^j\Phi_0(\tilde{\eta}, D_\delta\tilde{\eta}, D_\delta^2\tilde{\eta}, \delta\tilde{\eta}_t, \delta D_\delta\tilde{\eta}_t, \mathbf{u}^\delta, \delta^2v_x; y)\|^2 \lesssim \min\{\tilde{E}_m, D_m\}$$

$$(5.25) \quad \delta\|\partial_x^l\partial_y^j\Phi_0(\tilde{\eta}, D_\delta\tilde{\eta}, D_\delta^2\tilde{\eta}, D_\delta^3\tilde{\eta}, \delta\tilde{\eta}_t, \delta D_\delta\tilde{\eta}_t, \delta D_\delta^2\tilde{\eta}_t, \mathbf{u}^\delta, \delta\mathbf{u}_x^\delta; y)\|^2 \lesssim \tilde{F}_m.$$

Remark 5.2. As for (5.25), if Φ_0 does not contain $\tilde{\eta}$ and u , then δ appearing in the coefficient of the term $\|\partial_x^l\partial_y^j\Phi_0\|^2$ is unnecessary and we can replace l with k .

This lemma together with Lemma 3.2 gives the following lemma.

Lemma 5.8. *The following estimates hold.*

$$(5.26) \quad |\Phi_0(\eta, \delta\eta_x, \delta^2\eta_{xx}, \mathbf{u}^\delta|_\Gamma, \delta^2v_x|_\Gamma)|_{L^\infty}^2 \lesssim \min\{\tilde{E}_2, D_2\},$$

$$(5.27) \quad \delta|\Phi_0(\eta, \delta\eta_x, \delta^2\eta_{xx}, \mathbf{u}^\delta|_\Gamma, \delta^2v_x|_\Gamma)|_{m+\frac{1}{2}}^2 \lesssim \min\{\tilde{E}_m, D_m\},$$

$$(5.28) \quad |\Phi_0(\eta, \delta\eta_x, \delta^2\eta_{xx}, \mathbf{u}^\delta|_\Gamma, \delta^2v_x|_\Gamma)|_m^2 \lesssim \min\{\tilde{E}_m, D_m\}.$$

By (5.6) in Lemma 5.4, (5.12) in Lemma 5.5 and Lemma 3.2, we obtain the following lemma.

Lemma 5.9. *The following estimates hold.*

$$(5.29) \quad \mathbb{W}|\Phi_0(\delta\eta_x, \delta^2\eta_{xx})|_{L^\infty}^2 \lesssim \min\{\tilde{E}_2, D_2\},$$

$$(5.30) \quad \delta\mathbb{W}|\Phi_0(\delta\eta_x, \delta^2\eta_{xx})|_{m+\frac{1}{2}}^2 \lesssim \min\{\tilde{E}_m, D_m\},$$

$$(5.31) \quad \mathbb{W}|\Phi_0(\delta\eta_x, \delta^2\eta_{xx})|_m^2 \lesssim \min\{\tilde{E}_m, D_m\}.$$

We set

$$(5.32) \quad W = (w_1, \dots, w_7) := (D_\delta\tilde{\eta}, D_\delta^2\tilde{\eta}, \delta\tilde{\eta}_t, \delta D_\delta\tilde{\eta}_t, D_\delta^3\tilde{\eta}, \delta D_\delta^2\tilde{\eta}_t, \delta\mathbf{u}_x^\delta).$$

Lemma 5.10. *For $j = 0, 1$, the following estimates hold.*

$$(5.33) \quad \delta^{-1}\|w_\lambda\|_{L^\infty}^2 \lesssim \min\{\delta\tilde{E}_2, \tilde{F}_2\} \quad \text{for } 1 \leq \lambda \leq 7,$$

$$(5.34) \quad \delta^{-1}\|\partial_x^k\partial_y^j w_\lambda\|^2 \lesssim \tilde{F}_m \quad \text{for } 1 \leq \lambda \leq 7,$$

$$(5.35) \quad \delta^{-2}\|\partial_x^{l-1}\partial_y^j w_\lambda\|^2 \lesssim \tilde{E}_m \quad \text{for } 1 \leq \lambda \leq 4.$$

Proof. (5.33) and (5.34) follow from Lemmas 5.4 and 5.5, respectively. In the same way as the proof of Lemma 5.5, we can show (5.35). \square

We begin to estimate the nonlinear terms. First, we will estimate h_1 , h_2 , h_3 , and $b_3\eta$. By the explicit form of h_1 defined by (2.27), h_1 is consist of terms in the form

$$(5.36) \quad \begin{cases} \Phi_0(\varepsilon\eta, \varepsilon\delta\eta_x, \varepsilon\mathbf{u}^\delta|_\Gamma)\delta^i\partial_x^i\eta & \text{for } i = 1, 2, \\ \Phi_0(\varepsilon\eta, \varepsilon\delta\eta_x)\delta\mathbf{u}_x^\delta|_\Gamma. \end{cases}$$

Although $h_{2,1}$ contains $\Phi(\varepsilon\eta, \varepsilon\delta\eta_x)\varepsilon\delta\eta_x u_y$ in addition to the above terms (see (2.24)), by using the boundary condition $u_y = -\delta^2 v_x + (2 + b_3)\eta + h_1$ on Γ , we can reduce the estimate of $h_{2,1}$ to that of h_1 . Moreover, we note that $\delta^2\mathbf{W}h_{2,2}$ is of the form $\delta^2\mathbf{W}\Phi_0(\varepsilon^2\delta^2\eta_x^2)\eta_{xx}$.

Lemma 5.11. *For any $\varepsilon > 0$ there exists a positive constant C_ε such that we have*

$$(5.37) \quad \delta^{-1}|(h_1, h_2)|_m^2 + \delta|(h_{1x}, h_{2x})|_m^2 \lesssim \tilde{E}_2\tilde{F}_m + \tilde{F}_2\tilde{E}_m,$$

$$(5.38) \quad \delta^2|(h_{1x}, h_{2x})|_{m+\frac{1}{2}}^2 \lesssim \tilde{E}_2\tilde{F}_m + \tilde{F}_2\tilde{E}_m,$$

$$(5.39) \quad \delta^{-1}|(h_1, h_2)|_{m-\frac{1}{2}}^2 \lesssim \tilde{E}_2\tilde{E}_m,$$

$$(5.40) \quad \delta|h_2|_{m+\frac{1}{2}}^2 \lesssim D_2D_m,$$

$$(5.41) \quad \delta|(\partial_x^k h_{1t}, \partial_x^k u_t)_\Gamma| + \delta|(\partial_x^k h_{2t}, \delta\partial_x^k v_t)_\Gamma| \leq \varepsilon\tilde{F}_m + C_\varepsilon(\tilde{E}_2\tilde{F}_m + \tilde{F}_2\tilde{E}_m),$$

$$(5.42) \quad \begin{cases} \delta|h_3|_m^2 + \delta^3|(h_{3x}, h_{3t})|_m^2 + \delta^5|h_{3xx}|_m^2 \lesssim \tilde{E}_2\tilde{F}_m + \tilde{F}_2\tilde{E}_m, \\ \delta^6\mathbf{W}|(\partial_x^k \eta_{xxxx}, \partial_x^k h_{3xx})_\Gamma| \leq \varepsilon\tilde{F}_m + C_\varepsilon\tilde{E}_2\tilde{F}_m, \end{cases}$$

$$(5.43) \quad \begin{cases} \delta|(b_3\eta)_x|_m^2 + \delta^3|(b_3\eta)_{xx}|_m^2 + \delta|(b_3\eta)_t|_m^2 \lesssim \tilde{E}_2\tilde{F}_m + \tilde{F}_2\tilde{E}_m, \\ |(\partial_x^k \eta, \partial_x^k (b_3\eta)_x)_\Gamma| + |(\partial_x^k \eta, \partial_x^k h_3)_\Gamma| + \delta^2\mathbf{W}|(\partial_x^k \eta_{xx}, \partial_x^k h_3 + \partial_x^k (b_3\eta)_x)_\Gamma| \\ + \delta^4\mathbf{W}|(\partial_x^k \eta_{txx}, \partial_x^k h_{3t})_\Gamma| \leq \varepsilon\tilde{F}_m + C_\varepsilon(\tilde{E}_2\tilde{F}_m + \tilde{F}_2\tilde{E}_m + \varepsilon\sqrt{\tilde{E}_2\tilde{E}_m}). \end{cases}$$

Moreover, if $\varepsilon \lesssim \delta$, then we have

$$(5.44) \quad |(\partial_x^k \eta, \partial_x^k (b_3\eta)_x)_\Gamma| + |(\partial_x^k \eta, \partial_x^k h_3)_\Gamma| + \delta^2\mathbf{W}|(\partial_x^k \eta_{xx}, \partial_x^k h_3 + \partial_x^k (b_3\eta)_x)_\Gamma| \\ + \delta^4\mathbf{W}|(\partial_x^k \eta_{txx}, \partial_x^k h_{3t})_\Gamma| \leq \varepsilon\tilde{F}_m + C_\varepsilon(\tilde{E}_2\tilde{F}_m + \tilde{F}_2\tilde{E}_m).$$

Remark 6.3. Concerning the terms in the left-hand side of (5.43), in the case where ε is not dominated by δ , we cannot estimate these terms by using \tilde{F}_m because the power of δ of these terms is not enough. These are the only terms which prevent from deriving a uniform estimate of the solution for all time.

Proof. Since ε is the nonlinear parameter, that is, ε measures the nonlinearity, it is sufficient to show the estimates in the case $\varepsilon = 1$ except the last estimate (5.44). Therefore, we will assume that $\varepsilon = 1$ in the following.

As for (5.37), it suffices to estimate

$$\begin{cases} J_1 := \delta^{2i-1}|\Phi_0^1\partial_x^i\eta|_m^2 & \text{for } i = 1, 2, 3, \\ J_2 := \delta^{2i-1}|\Phi_0^1\partial_x^i\mathbf{u}^\delta|_m^2 & \text{for } i = 1, 2, \\ J_3 := \delta^{2i+3}\mathbf{W}^2|\Phi_0^2\partial_x^i\eta_{xx}|_m^2 & \text{for } i = 0, 1, \end{cases}$$

where $\Phi_0^1 = \Phi_0(\eta, \delta\eta_x, \delta^2\eta_{xx}, \mathbf{u}^\delta|_\Gamma, \delta^2v_x|_\Gamma)$ and $\Phi_0^2 = \Phi_0(\delta\eta_x, \delta^2\eta_{xx})$. Note that we included the term $\delta^2v_x|_\Gamma$ in Φ_0^1 for later use, although we can drop it. In the following we use the inequality

$$(5.45) \quad |fg|_s \lesssim |f|_{L^\infty}|g|_s + |g|_{L^\infty}|f|_s.$$

By (5.45), (5.5) in Lemma 5.4, and (5.26) and (5.28) in Lemma 5.8, we obtain $J_1 \lesssim \tilde{E}_2\tilde{F}_m + \tilde{F}_2\tilde{E}_m$. By (5.45), the second inequality in (5.7) in Lemma 5.4, (5.26) and (5.28) in Lemma 5.8, and the second inequality in (5.20) in Lemma 5.6, we obtain $J_2 \lesssim \tilde{E}_2\tilde{F}_m + \tilde{F}_2\tilde{E}_m$. By (5.45), (5.6) in Lemma 5.4, and (5.29) and (5.31) in Lemma 5.9, we obtain $J_3 \lesssim \tilde{E}_2\tilde{F}_m + \tilde{F}_2\tilde{E}_m$. Thus (5.37) holds.

As for (5.38), it suffices to estimate

$$\begin{cases} J_4 := \delta^{2i}|\Phi_0^1\partial_x^i\eta|_{m+\frac{1}{2}}^2 & \text{for } i = 1, 2, 3, \\ J_5 := \delta^{2i}|\Phi_0^1\partial_x^i\mathbf{u}^\delta|_{m+\frac{1}{2}}^2 & \text{for } i = 1, 2, \\ J_6 := \delta^{2i+4}W^2|\Phi_0^2\partial_x^i\eta_{xx}|_{m+\frac{1}{2}}^2 & \text{for } i = 0, 1. \end{cases}$$

By (5.45), (5.5) in Lemma 5.4, the second inequality in (5.17) in Lemma 5.6, and (5.26) and (5.27) in Lemma 5.8, we obtain $J_4 \lesssim \tilde{E}_2\tilde{F}_m + \tilde{F}_2\tilde{E}_m$. By (5.45), the second inequality in (5.7) in Lemma 5.4, the second and third inequalities in (5.19) in Lemma 5.6, and (5.26) and (5.27) in Lemma 5.8 we obtain $J_5 \lesssim \tilde{E}_2\tilde{F}_m + \tilde{F}_2\tilde{E}_m$. By (5.45), (5.6) in Lemma 5.4, the second inequality in (5.18) in Lemma 5.6, and (5.29) and (5.30) in Lemma 5.9, we obtain $J_6 \lesssim \tilde{E}_2\tilde{F}_m + \tilde{F}_2\tilde{E}_m$. Thus (5.38) holds.

As for (5.39), it suffices to estimate

$$\begin{cases} J_7 := \delta^{2i+1}|\Phi_0^1\partial_x^i\eta_x|_{m-\frac{1}{2}}^2 & \text{for } i = 0, 1, \\ J_8 := \delta|\Phi_0^1\mathbf{u}_x^\delta|_{m-\frac{1}{2}}^2, \\ J_9 := \delta^3W^2|\Phi_0^2\eta_{xx}|_{m-\frac{1}{2}}^2. \end{cases}$$

By (5.45), (5.5) in Lemma 5.4, the first inequality in (5.17) in Lemma 5.6, and (5.26) and (5.28) in Lemma 5.8, we obtain $J_7 \lesssim \tilde{E}_2\tilde{E}_m$. By (5.45), (5.7) in Lemma 5.4, the first inequality in (5.19) in Lemma 5.6, and (5.26) and (5.28) in Lemma 5.8, we obtain $J_8 \lesssim \tilde{E}_2\tilde{E}_m$. By (5.45), (5.6) in Lemma 5.4, the first inequality in (5.18) in Lemma 5.6, and (5.29) and (5.31) in Lemma 5.9, we obtain $J_9 \lesssim \tilde{E}_2\tilde{E}_m$. Thus (5.39) holds.

As for (5.40), it suffices to estimate

$$\begin{cases} J_{10} := \delta^{2i+1}|\Phi_0^1\partial_x^i\eta|_{m+\frac{1}{2}}^2 & \text{for } i = 1, 2, \\ J_{11} := \delta^3|\Phi_0^1\mathbf{u}_x^\delta|_{m+\frac{1}{2}}^2, \\ J_{12} := \delta^5W^2|\Phi_0^2\eta_{xx}|_{m+\frac{1}{2}}^2. \end{cases}$$

By (5.45), (5.5) in Lemma 5.4, the first inequality in (5.17) in Lemma 5.6, and (5.26) and (5.27) in Lemma 5.8, we obtain $J_{10} \lesssim D_2D_m$. By (5.45), (5.7) in Lemma 5.4, the first inequality in (5.19) in Lemma 5.6, and (5.26) and (5.27) in Lemma 5.8, we obtain $J_{11} \lesssim D_2D_m$. By (5.45), (5.6) in Lemma 5.4, the first inequality in (5.18) in Lemma 5.6, and (5.29) and (5.30) in Lemma 5.9, we obtain $J_{12} \lesssim D_2D_m$. Thus (5.40) holds.

We proceed to estimate (5.41). By the third equation in (2.29), we can reduce the estimates of the terms which contain η_t except the terms which accompany W to those of J_1 , J_2 , and J_4 .

Thus it suffices to estimate

$$\begin{cases} J_{13} := \delta^9 \mathbb{W}^2 |\Phi^3 \eta_x \eta_{xx} \eta_{tx}|_m^2, \\ J_{14} := \delta^9 \mathbb{W}^2 |\Phi^3 \eta_x^2 \eta_{tx}|_m^2, \\ J_{15} := \delta |\Phi_0^1 \mathbf{u}_t^\delta|_m^2, \\ J_{16} := \delta^2 |(\partial_x^k (\Phi_0^4 \mathbf{u}_{tx}^\delta), \partial_x^k \mathbf{u}_t^\delta)_\Gamma|, \end{cases}$$

where $\Phi^3 = \Phi(\delta\eta_x)$, $\Phi_0^4 = \Phi_0(\eta, \delta\eta_x)$ and we used $h_{2,2} = \Phi_0(\delta^2 \eta_x^2) \eta_{xx} = \Phi(\delta\eta_x) \delta^2 \eta_x^2 \eta_{xx}$. Taking into account that $\delta^9 \mathbb{W}^2 \lesssim \delta^5$, by the third equation in (2.29), we can reduce the estimates of J_{13} and J_{14} to those of J_1 , J_2 , and J_4 . By (5.45), the second inequality in (5.7) in Lemma 5.4, (5.26) and (5.28) in Lemma 5.8, and $\delta |\mathbf{u}_t^\delta|_m^2 \lesssim \delta \|(1 + |D_x|)^m \mathbf{u}_{ty}^\delta\|^2 \lesssim \tilde{F}_m$, we obtain $J_{15} \lesssim \tilde{E}_2 \tilde{F}_m + \tilde{F}_2 \tilde{E}_m$. By Lemma 3.2, we see that

$$\begin{aligned} J_{16} &= \delta^2 |(\partial_x^k \{(\Phi_0^4 \mathbf{u}_t^\delta)_x - \Phi_{0x}^4 \mathbf{u}_t^\delta\}, \partial_x^k \mathbf{u}_t^\delta)_\Gamma| \\ &\leq \delta^2 \| |D_x|^{\frac{1}{2}} \partial_x^k (\Phi_0^4 \mathbf{u}_t^\delta) |_{0} \| |D_x|^{\frac{1}{2}} \partial_x^k \mathbf{u}_t^\delta |_{0} + \delta^2 |(\partial_x^k (\Phi_0^4 \mathbf{u}_t^\delta), \partial_x^k \mathbf{u}_t^\delta)_\Gamma| \\ &\leq \epsilon (\delta \|\partial_x^k \mathbf{u}_t^\delta\|^2 + \delta^3 \|\partial_x^k \mathbf{u}_{tx}^\delta\|^2 + \delta \|\partial_x^k \mathbf{u}_{ty}^\delta\|^2) + C_\epsilon (\delta^2 |\Phi_0^4 \mathbf{u}_t^\delta|_{m+\frac{1}{2}}^2 + \delta^3 |\Phi_{0x}^4 \mathbf{u}_t^\delta|_m^2). \end{aligned}$$

Here, we can reduce the estimate of $\delta^3 |\Phi_{0x}^4 \mathbf{u}_t^\delta|_m^2$ to that of J_8 . By (5.45), the second inequality in (5.7) in Lemma 5.4, (5.21) in Lemma 5.6, and (5.26) and (5.27) in Lemma 5.8, we obtain $\delta^2 |\Phi_0^4 \mathbf{u}_t^\delta|_{m+\frac{1}{2}}^2 \lesssim \tilde{E}_2 \tilde{F}_m + \tilde{F}_2 \tilde{E}_m$. We thereby deduce $J_{16} \leq \epsilon \tilde{F}_m + C_\epsilon (\tilde{E}_2 \tilde{F}_m + \tilde{F}_2 \tilde{E}_m)$. Thus (5.41) holds.

As for (5.42), since $h_3 = \eta^2 \eta_x$ is contained in the first term in (5.36), we have already checked that the first inequality holds. As for the second inequality, we have

$$\delta^6 \mathbb{W} |(\partial_x^k \eta_{xxxx}, \partial_x^k h_{3xx})_\Gamma| \leq \epsilon \delta^6 \mathbb{W} \| |D_x|^{k+\frac{7}{2}} \eta \|_0^2 + C_\epsilon \delta^6 \mathbb{W} \| |D_x|^{k+\frac{5}{2}} h_3 \|_0^2.$$

Here, (5.16) leads to $\delta^6 \mathbb{W} \| |D_x|^{k+\frac{5}{2}} h_3 \|_0^2 \lesssim \tilde{E}_2 \tilde{F}_m$. Therefore, we get the second inequality.

As for (5.43), taking into account that we can write b_3 as Φ_0^4 (see (2.26)), we obtain the first inequality in the same reason as the last estimate. Concerning the term $|(\partial_x^k \eta, \partial_x^k (b_3 \eta)_x)_\Gamma|$ in the second inequality, there exist rational functions $b_{3,1}$ and $b_{3,2}$ such that $b_3 \eta = b_{3,1}(\eta) + b_{3,2}(\eta, \delta\eta_x) \delta\eta_x$ and $b_{3,2}(\mathbf{0}) = 0$. Since the term $b_{3,2}(\eta, \delta\eta_x) \delta\eta_x$ can be treated in the same way as before, it suffices to estimate

$$J_{17} := |(\partial_x^k \eta, \partial_x^{k+1} b_{3,1}(\eta))_\Gamma|.$$

Here we can assume that $k \geq 1$ because we have $(\eta, b_{3,1}(\eta)_x)_\Gamma = 0$ in the case $k = 0$. We see that $J_{17} \leq |(\partial_x^k \eta, b'_{3,1}(\eta) \partial_x^{k+1} \eta)_\Gamma| + |(\partial_x^k \eta, [\partial_x^k, b'_{3,1}(\eta)] \eta_x)_\Gamma|$, where by integration by parts we have $|(\partial_x^k \eta, b'_{3,1}(\eta) \partial_x^{k+1} \eta)_\Gamma| = \frac{1}{2} |(\partial_x^k \eta, b''_{3,1}(\eta) \eta_x \partial_x^k \eta)_\Gamma| \lesssim \sqrt{\tilde{E}_2} |\eta_x|_{m-1}^2$. In view of

$$|[\partial_x^k, b'_{3,1}(\eta)] \eta_x|_0 \leq C (|\eta|_{L^\infty}) (1 + |\eta_x|_{L^\infty})^{k-1} |\eta_x|_{L^\infty} |\partial_x^{k-1} \eta_x|_0,$$

we also have $|(\partial_x^k \eta, [\partial_x^k, b'_{3,1}(\eta)] \eta_x)_\Gamma| \lesssim \sqrt{\tilde{E}_2} |\eta_x|_{m-1}^2$. Therefore, $J_{17} \lesssim \sqrt{\tilde{E}_2} \min\{\tilde{E}_m, \delta^{-1} \tilde{F}_m\}$, so that we obtain

$$|(\partial_x^k \eta, \partial_x^k (b_3 \eta)_x)_\Gamma| \leq \epsilon \tilde{F}_m + C_\epsilon (\tilde{E}_2 \tilde{F}_m + \tilde{F}_2 \tilde{E}_m) + C \sqrt{\tilde{E}_2} \min\{\tilde{E}_m, \delta^{-1} \tilde{F}_m\}.$$

As for the the term $\delta^4 \mathbb{W} |(\partial_x^k \eta_{txx}, \partial_x^k h_{3t})_\Gamma|$, integration by parts in x leads to

$$\begin{aligned} \delta^4 \mathbb{W} |(\partial_x^k \eta_{txx}, \partial_x^k h_{3t})_\Gamma| &\leq \delta^4 \mathbb{W} |(\partial_x^k \eta_{txx}, \partial_x^k (\eta^2 \eta_{tx}))_\Gamma| + \delta^4 \mathbb{W} |(\partial_x^k \eta_{txx}, \partial_x^k (2\eta \eta_t \eta_x))_\Gamma| \\ &\leq \delta^4 \mathbb{W} |(\partial_x^k \eta_{tx}, \eta \eta_x \partial_x^k \eta_{tx})_\Gamma| + \delta^4 \mathbb{W} |(\partial_x^k \eta_{tx}, ([\partial_x^k, \eta^2] \eta_{tx})_x)_\Gamma| \\ &\quad + \delta^4 \mathbb{W} |(\partial_x^k \eta_{tx}, \partial_x^k (2\eta \eta_t \eta_x)_x)_\Gamma| \\ &=: J_{18} + J_{19} + J_{20}. \end{aligned}$$

Here, it follows from the third equation in (2.29) that $\delta^4 \mathbf{W} |\partial_x^k \eta_{tx}|_0^2 \lesssim \delta^2 (|\partial_x^k \eta_{xx}|_0^2 + |\partial_x^k v_x|_0^2 + |\partial_x^k h_{3x}|_0^2) \lesssim \delta^{-1} \tilde{F}_m$ and $\delta^4 \mathbf{W} |\partial_x^k \eta_{tx}|_0^2 \lesssim \tilde{E}_m$ so that we have

$$(5.46) \quad \delta^4 \mathbf{W} |\partial_x^k \eta_{tx}|_0^2 \lesssim \min\{\tilde{E}_m, \delta^{-1} \tilde{F}_m\}.$$

By (5.5) in Lemma 5.4 and (5.46), we have $J_{18} \lesssim \tilde{E}_2 \min\{\tilde{E}_m, \delta^{-1} \tilde{F}_m\}$. By the estimate

$$|([\partial_x^k, \eta^2] \eta_{tx})_x|_0 \lesssim |\eta|_{L^\infty} |\eta_x|_{L^\infty} |\partial_x^k \eta_{tx}| + |\eta|_{L^\infty} |\eta_{tx}|_{L^\infty} |\partial_x^k \eta_x| + |\eta_x|_{L^\infty} |\eta_{tx}|_{L^\infty} |\partial_x^k \eta|,$$

(5.5), (5.6), and (5.8) in Lemma 5.4, and (5.46), we easily obtain $J_{19} \leq \epsilon \tilde{F}_m + C_\epsilon \tilde{F}_2 \tilde{E}_m + C \tilde{E}_2 \min\{\tilde{E}_m, \delta^{-1} \tilde{F}_m\}$. By (5.45) and (5.5), (5.6), and (5.8) in Lemma 5.4, and (5.46), we have $J_{20} \leq \epsilon \tilde{F}_m + C_\epsilon \tilde{E}_2 \tilde{F}_m + C \tilde{E}_2 \min\{\tilde{E}_m, \delta^{-1} \tilde{F}_m\}$. Therefore, we get the third inequality. Thus far, we have assumed that $\varepsilon = 1$. Now, for general $\varepsilon \in (0, 1]$ it follows easily from the above estimate that

$$|(\partial_x^k \eta, \partial_x^k (b_3 \eta)_x)_\Gamma| \leq \epsilon \tilde{F}_m + \varepsilon^2 C_\epsilon (\tilde{E}_2 \tilde{F}_m + \tilde{F}_2 \tilde{E}_m) + C \sqrt{\tilde{E}_2} \min\{\varepsilon \tilde{E}_m, \varepsilon \delta^{-1} \tilde{F}_m\}.$$

The term $|(\partial_x^k \eta, \partial_x^k h_3)_\Gamma|$ is of the form J_{17} , so that it also satisfies the above estimate. Moreover, by taking into account that $\delta \sqrt{\mathbf{W}} |\eta_x|_{L^\infty} \lesssim \sqrt{\tilde{E}_2}$ and $\delta^2 \mathbf{W} |\eta_x|_{m-1}^2 \lesssim |\eta_x|_{m-1}^2 \lesssim \min\{\tilde{E}_m, \delta^{-1} \tilde{F}_m\}$, the term $\delta^2 \mathbf{W} |(\partial_x^k \eta_{xx}, \partial_x^k h_3 + \partial_x^k (b_3 \eta)_x)_\Gamma|$ also satisfies the above estimate. Similarly, we obtain

$$\delta^4 \mathbf{W} |(\partial_x^k \eta_{txx}, \partial_x^k h_{3t})_\Gamma| \leq \epsilon \tilde{F}_m + \varepsilon^2 C_\epsilon (\tilde{E}_2 \tilde{F}_m + \tilde{F}_2 \tilde{E}_m) + C \tilde{E}_2 \min\{\varepsilon \tilde{E}_m, \varepsilon \delta^{-1} \tilde{F}_m\}.$$

Therefore, the second inequalities in (5.43) and (5.44) hold. The proof is complete. \square

Next, we will estimate $f_1, f_2, \mathbf{F}_1, \mathbf{F}_2$, and \mathbf{G}_k . By the explicit form of \mathbf{f} (see (2.20)), we see that this is consist of terms in the form

$$\begin{cases} \Phi_0(\tilde{\eta}, D_\delta \tilde{\eta}, \mathbf{u}^\delta; y) D_\delta^3 \tilde{\eta}, \\ \Phi_0(\tilde{\eta}, D_\delta \tilde{\eta}; y) \delta^i \partial_x^i \partial_y^j u & \text{for } (i, j) = (2, 0), (1, 1), \\ \Phi(\tilde{\eta}, D_\delta \tilde{\eta}, \mathbf{u}^\delta, y) w_\lambda u_y & \text{for } 1 \leq \lambda \leq 3, \\ \Phi(\tilde{\eta}, D_\delta \tilde{\eta}, D_\delta^2 \tilde{\eta}, \mathbf{u}^\delta, y) w_\lambda \mathbf{u}^\delta & \text{for } 1 \leq \lambda \leq 4, \\ \Phi_0(\tilde{\eta}, D_\delta \tilde{\eta}, D_\delta^2 \tilde{\eta}, \delta \tilde{\eta}_t, \mathbf{u}^\delta; y) \delta \mathbf{u}_x^\delta, \end{cases}$$

where w_λ is defined by (5.32). Thus by the explicit forms of f_1 and f_2 (see (3.16) and (3.23)), we see that these contain the above terms, $\Phi_0(\tilde{\eta}, D_\delta \tilde{\eta}; y) \nabla_\delta p$, and $\Phi_0(\tilde{\eta}, D_\delta \tilde{\eta}; y) \delta u_t$ (see also (2.21)). In addition to these terms, \mathbf{F}_1 contains also $\Phi_0(\tilde{\eta}, D_\delta \tilde{\eta}; y) u_{yy}$ (see (3.2)).

Lemma 5.12. *For any $\epsilon > 0$ there exists a positive constant C_ϵ such that the following estimates hold.*

$$(5.47) \quad \delta^{-1} \|\partial_x^k f_1\|^2 + \delta^{-1} \|\partial_x^k f_2\|^2 + \delta \|\partial_x^k f_{1x}\|^2 + \delta |(\partial_x^k \mathbf{F}_{1x}, \partial_x^k \mathbf{u}_x^\delta)_\Omega| + \delta^3 |(\partial_x^k \mathbf{F}_{1xx}, \partial_x^k \mathbf{u}_{xx}^\delta)_\Omega| \leq \epsilon \tilde{F}_m + C_\epsilon (\tilde{E}_2 \tilde{F}_m + \tilde{F}_2 \tilde{E}_m),$$

$$(5.48) \quad \delta^{-2} \|\partial_x^{l-1} \mathbf{f}\|^2 \lesssim \tilde{E}_2 \tilde{E}_m,$$

$$(5.49) \quad |(\partial_x^l \{A_4 \nabla_\delta p + (b_2 u_{yy}, 0)^T\}, \partial_x^l \mathbf{u}^\delta)_\Omega| \leq (\epsilon + C_\epsilon \tilde{E}_2) \tilde{E}_m,$$

$$(5.50) \quad \|\partial_x^k \mathbf{f}\|^2 \lesssim D_2 D_m,$$

$$(5.51) \quad \delta |(\partial_x^k \mathbf{F}_2, \partial_x^k \mathbf{u}_t^\delta)_\Omega| \leq \epsilon \tilde{F}_m + C_\epsilon (\tilde{E}_2 \tilde{F}_m + \tilde{F}_2 \tilde{E}_m),$$

$$(5.52) \quad \delta |(\mathbf{G}_k, \partial_x^k \mathbf{u}_t^\delta)_\Omega| \leq \epsilon \tilde{F}_m + C_\epsilon (\tilde{E}_2 \tilde{F}_m + \tilde{F}_2 \tilde{E}_m).$$

Proof. As for (5.47), the definition of \mathbf{F}_1 and integration by parts in x imply

$$\begin{aligned} \delta^3 |(\partial_x^k \mathbf{F}_{1xx}, \partial_x^k \mathbf{u}_{xx}^\delta)_\Omega| &\leq \epsilon \delta^5 \|\partial_x^k \mathbf{u}_{xxx}^\delta\|^2 + C_\epsilon \delta \|\partial_x^k (\mathbf{f} - \Phi_0(\tilde{\eta}, D_\delta \tilde{\eta}) \nabla_\delta p)_x\|^2 \\ &\quad + \delta^3 |(\partial_x^k (\Phi_0(\tilde{\eta}, D_\delta \tilde{\eta}) u_{yy})_{xx}, \partial_x^k \mathbf{u}_{xx}^\delta)_\Omega|. \end{aligned}$$

Taking this into account, it suffices to estimate

$$\begin{cases} K_1 := \delta^{-1} \|\partial_x^k (\Phi_0^5 D_\delta^i \tilde{\eta})\|^2 & \text{for } 1 \leq i \leq 4, \\ K_2 := \delta^{-1} \|\partial_x^k (\Phi_0^5 \delta \tilde{\eta}_t)\|^2, \\ K_3 := \delta^{2i-1} \|\partial_x^k (\Phi_0^5 \partial_x^i u_y)\|^2 & \text{for } i = 1, 2, \\ K_4 := \delta^{-1} \|\partial_x^k (\Phi_0^5 w_\lambda \partial_y^j u)\|^2 & \text{for } 1 \leq \lambda \leq 7, j = 0, 1, \\ K_5 := \delta^{2i-1} \|\partial_x^k (\Phi_0^6 \partial_x^i \mathbf{u}^\delta)\|^2 & \text{for } i = 1, 2, 3 \\ K_6 := \delta^{2i-1} |(\partial_x^{k+i} (\Phi_0^7 u_{yy}), \partial_x^{k+i} \mathbf{u}^\delta)_\Omega| & \text{for } i = 1, 2, \\ K_7 := \delta^{2i-1} \|\partial_x^{k+i} (\Phi_0^7 \nabla_\delta p)\|^2 & \text{for } i = 0, 1, \end{cases}$$

where

$$\begin{aligned} \Phi^5 &= \Phi(\tilde{\eta}, D_\delta \tilde{\eta}, D_\delta^2 \tilde{\eta}, \delta \tilde{\eta}_t, \delta D_\delta \tilde{\eta}_t, \mathbf{u}^\delta; y), \\ \Phi^6 &= \Phi(\tilde{\eta}, D_\delta \tilde{\eta}, D_\delta^2 \tilde{\eta}, D_\delta^3 \tilde{\eta}, \delta \tilde{\eta}_t, \delta D_\delta \tilde{\eta}_t, \delta D_\delta^2 \tilde{\eta}_t, \mathbf{u}^\delta, \delta \mathbf{u}_x^\delta; y), \\ \Phi^7 &= \Phi(\tilde{\eta}, D_\delta \tilde{\eta}; y). \end{aligned}$$

In the following we will use the well-known inequality

$$(5.53) \quad \|\partial_x^k (fg)\| \lesssim \|f\|_{L^\infty} \|\partial_x^k g\| + \|g\|_{L^\infty} \|\partial_x^k f\|.$$

By this, (5.5) in Lemma 5.4, (5.11) and (5.13) in Lemma 5.5, and (5.22) and (5.23) in Lemma 5.7, we obtain $K_1 \lesssim \tilde{E}_2 \tilde{F}_m + \tilde{F}_2 \tilde{E}_m$. Similarly, we get $K_2 \lesssim \tilde{E}_2 \tilde{F}_m + \tilde{F}_2 \tilde{E}_m$. By Lemma 5.2, we have

$$K_3 \lesssim \|\Phi_0^5\|_{L^\infty}^2 \delta^{2i-1} \|\partial_x^{k+i} u_y\|^2 + (\|\partial_x^k \Phi_0^5\|^2 + \|\partial_x^k \Phi_{0y}^5\|^2) \delta^{2i-1} (\|\partial_x^i u_y\|^2 + \|\partial_x^i u_{xy}\|^2),$$

which together with (5.22) and (5.24) in Lemma 5.7 gives $K_3 \lesssim \tilde{E}_2 \tilde{F}_m + \tilde{E}_m \tilde{F}_2$. By Lemma 5.2, we have

$$\begin{aligned} K_4 &\lesssim \|\Phi^5\|_{L^\infty}^2 \delta^{-1} \|w_\lambda\|_{L^\infty}^2 \|\partial_x^k \partial_y^j u\|^2 \\ &\quad + \delta^{-1} \|w_\lambda\|_{L^\infty}^2 (\|\partial_x^k \Phi^5\|^2 + \|\partial_x^k \Phi_y^5\|^2) (\|\partial_y^j u\|^2 + \|\partial_y^j u_x\|^2) \\ &\quad + \|\Phi^5\|_{L^\infty}^2 \delta^{-1} (\|\partial_x^k w_\lambda\|^2 + \|\partial_x^k w_{\lambda y}\|^2) (\|\partial_y^j u\|^2 + \|\partial_y^j u_x\|^2), \end{aligned}$$

which together with (5.22) and (5.24) in Lemma 5.7 and (5.33) and (5.34) in Lemma 5.10 gives $K_4 \lesssim \tilde{E}_2 \tilde{F}_m + \tilde{F}_2 \tilde{E}_m$. As for K_5 , it suffices to consider the case of $k \geq 1$ since we can easily treat the case of $k = 0$. By Lemma 5.2, we have

$$K_5 \lesssim \|\Phi_0^6\|_{L^\infty}^2 \delta^{2i-1} \|\partial_x^{k+i} \mathbf{u}^\delta\|^2 + \delta (\|\partial_x^k \Phi_0^6\|^2 + \|\partial_x^k \Phi_{0y}^6\|^2) \delta^{2(i-1)} (\|\partial_x^i \mathbf{u}^\delta\|^2 + \|\partial_x^i \mathbf{u}_x^\delta\|^2),$$

which together with (5.22) and (5.25) in Lemma 5.7 gives $K_5 \lesssim \tilde{E}_2 \tilde{F}_m$. As for K_6 , we will consider the case $i = 2$ only, because the case where $i = 1$ can be treated in a similar but easier way. Using integration by parts in x and y and Lemma 3.2, we have

$$\begin{aligned} K_6 &= \delta^3 |(\partial_x^k \{(\Phi_0^7 u_y)_{xxy} - (\Phi_0^7 u_y)_{xx}\}, \partial_x^k \mathbf{u}_{xx}^\delta)_\Omega| \\ &\leq \delta^3 |(\partial_x^k (\Phi_0^7 u_y)_{xx}, \partial_x^k \mathbf{u}_{xxy}^\delta)_\Omega| + \delta^3 \| |D_x|^{\frac{1}{2}} \partial_x^k (\Phi_0^7 u_y)_x \| \| |D_x|^{\frac{1}{2}} \partial_x^k \mathbf{u}_{xx}^\delta \|_0 \\ &\quad + \delta^3 |(\partial_x^k (\Phi_0^7 u_y)_x, \partial_x^k \mathbf{u}_{xxx}^\delta)_\Omega| \\ &\leq \epsilon \tilde{F}_m + C_\epsilon (\delta^3 \|\partial_x^k (\Phi_0^7 u_y)_{xx}\|^2 + \delta \|\partial_x^k (\Phi_0^7 u_y)_x\|^2 + \delta^2 \| |D_x|^{\frac{1}{2}} \partial_x^k (\Phi_0^7 u_y)_x \|^2_0). \end{aligned}$$

Here we can reduce the estimate of $\delta^3 \|\partial_x^k (\Phi_0^7 u_y)_{xx}\|^2 + \delta \|\partial_x^k (\Phi_{0y}^7 u_y)_x\|^2$ to those of K_3 and K_4 . Furthermore, using the first equation in (2.29) to eliminate $u_y|_\Gamma$, we can reduce the estimate of $\delta^2 \|D_x|^\frac{1}{2} \partial_x^k (\Phi_0^7 u_y)_x\|_0^2$ to those of J_4 and J_5 . Thus combining these estimates, we obtain $K_6 \leq \epsilon \tilde{F}_m + C_\epsilon (\tilde{E}_2 \tilde{F}_m + \tilde{F}_2 \tilde{E}_m)$. By Lemma 5.2, we have

$$K_7 \lesssim \|\Phi_0^7\|_{L^\infty}^2 \delta^{2i-1} \|\nabla_\delta \partial_x^{k+i} p\|^2 + \delta^{2i} (\|\partial_x^{k+i} \Phi_0^7\|^2 + \|\partial_x^{k+i} \Phi_{0y}^7\|^2) \delta^{-1} (\|\nabla_\delta p\|^2 + \|\nabla_\delta p_x\|^2),$$

which together with (5.22) and (5.24) in Lemma 5.7 gives $K_7 \lesssim \tilde{E}_2 \tilde{F}_m + \tilde{E}_m \tilde{F}_2$. Thus (5.47) holds.

As for (5.48), it suffices to estimate

$$\begin{cases} K_8 := \delta^{-2} \|\partial_x^{l-1} (\Phi_0^5 D_\delta^3 \tilde{\eta})\|^2, \\ K_9 := \|\partial_x^{l-1} (\Phi_0^5 u_{xy})\|^2, \\ K_{10} := \delta^{-2} \|\partial_x^{l-1} (\Phi^5 w_\lambda \partial_y^j \mathbf{u}^\delta)\|^2 \quad \text{for } 1 \leq \lambda \leq 4, j = 0, 1, \\ K_{11} := \delta^{2i} \|\partial_x^{l-1} (\Phi_0^5 \partial_x^i \mathbf{u}^\delta)\|^2 \quad \text{for } i = 0, 1. \end{cases}$$

By (2.7) in Lemma 2.1, we have $\delta^{-2} \|\partial_x^{l-1} D_\delta^3 \tilde{\eta}\|^2 \lesssim \delta^4 \|\partial_x^l \eta_{xx}\|_0^2$. Therefore, by (5.53), (5.10) in Lemma 5.4, and (5.22) and (5.23) in Lemma 5.7, we obtain $K_8 \lesssim \tilde{E}_2 \tilde{E}_m$. By Lemma 5.2, we have

$$K_9 \lesssim \|\Phi_0^5\|_{L^\infty}^2 \|\partial_x^l \mathbf{u}_y^\delta\|^2 + (\|\partial_x^{l-1} \Phi_0^5\|^2 + \|\partial_x^{l-1} \Phi_{0y}^5\|^2) (\|u_{xy}\|^2 + \|u_{xxy}\|^2),$$

which together with (5.22) and (5.24) in Lemma 5.7 gives $K_9 \lesssim \tilde{E}_2 \tilde{E}_m$. By Lemma 5.2, we have

$$\begin{aligned} K_{10} &\lesssim \|\Phi^5\|_{L^\infty}^2 \delta^{-2} \|w_\lambda\|_{L^\infty}^2 \|\partial_x^{l-1} \partial_y^j \mathbf{u}^\delta\|^2 \\ &\quad + \delta^{-2} \|w_\lambda\|_{L^\infty}^2 (\|\partial_x^{l-1} \Phi^5\|^2 + \|\partial_x^{l-1} \Phi_y^5\|^2) (\|\partial_y^j \mathbf{u}^\delta\|^2 + \|\partial_y^j \mathbf{u}_x^\delta\|^2) \\ &\quad + \|\Phi^5\|_{L^\infty}^2 \delta^{-2} (\|\partial_x^{l-1} w_\lambda\|^2 + \|\partial_x^{l-1} w_{\lambda y}\|^2) (\|\partial_y^j \mathbf{u}^\delta\|^2 + \|\partial_y^j \mathbf{u}_x^\delta\|^2), \end{aligned}$$

which together with (5.22) and (5.24) in Lemma 5.7 and (5.33) and (5.35) in Lemma 5.10 gives $K_{10} \lesssim \tilde{E}_2 \tilde{E}_m$. By Lemma 5.2, we have

$$K_{11} \lesssim \|\Phi_0^5\|_{L^\infty}^2 \delta^{2i} \|\partial_x^{l+i} \mathbf{u}^\delta\|^2 + (\|\partial_x^{l-1} \Phi_0^5\|^2 + \|\partial_x^{l-1} \Phi_{0y}^5\|^2) \delta^{2i} (\|\partial_x^i \mathbf{u}^\delta\|^2 + \|\partial_x^i \mathbf{u}_{xx}^\delta\|),$$

which together with (5.22) and (5.24) in Lemma 5.7 gives $K_{11} \lesssim \tilde{E}_2 \tilde{E}_m$. Thus (5.48) holds.

We proceed to estimate (5.49). With the aid of (3.11), we can express $A_4 \nabla_\delta p$ in terms of the product of Φ_0^7 and derivatives of \mathbf{u}^δ in addition to $\Phi_0^7 \mathbf{f}$. Taking this into account and using (5.48), it suffices to estimate

$$\begin{cases} K_{12} := \delta^2 \|\partial_x^l (\Phi_0^7 \mathbf{u}_t^\delta)\|^2, \\ K_{13} := |(\partial_x^l (\Phi_0^7 \mathbf{u}_{yy}^\delta), \partial_x^l \mathbf{u}^\delta)_\Omega|. \end{cases}$$

By Lemma 5.2, we have

$$K_{12} \lesssim \|\Phi_0^7\|_{L^\infty}^2 \delta^2 \|\partial_x^l \mathbf{u}_t^\delta\|^2 + (\|\partial_x^l \Phi_0^7\|^2 + \|\partial_x^l \Phi_{0y}^7\|^2) \delta^2 (\|\mathbf{u}_t^\delta\|^2 + \|\mathbf{u}_{tx}^\delta\|^2),$$

which together with (5.22) and (5.24) in Lemma 5.7 gives $K_{12} \lesssim \tilde{E}_2 \tilde{E}_m$. Integration by parts in y implies

$$\begin{aligned} K_{13} &= |(\partial_x^l \{(\Phi_0^7 \mathbf{u}_y^\delta)_y - \Phi_{0y}^7 \mathbf{u}_y^\delta\}, \partial_x^l \mathbf{u}^\delta)_\Omega| \\ &\leq \|\partial_x^l (\Phi_0^7 \mathbf{u}^\delta)\| \|\partial_x^l \mathbf{u}_y^\delta\| + |(\partial_x^l (\Phi_0^7 \mathbf{u}_y^\delta), \partial_x^l \mathbf{u}^\delta)_\Gamma| + \|\partial_x^l (\Phi_{0y}^7 \mathbf{u}_y^\delta)\| \|\partial_x^l \mathbf{u}^\delta\| \\ &\leq \epsilon \tilde{E}_m + C_\epsilon (\|\partial_x^l (\Phi_0^7 \mathbf{u}_y^\delta)\|^2 + \|\partial_x^l (\Phi_{0y}^7 \mathbf{u}_y^\delta)\|^2) + |(\partial_x^l (\Phi_0^7 \mathbf{u}_y^\delta), \partial_x^l \mathbf{u}^\delta)_\Gamma|. \end{aligned}$$

Here the estimates of $\|\partial_x^l(\Phi_0^7 \mathbf{u}_y^\delta)\|^2$ and $\|\partial_x^l(\Phi_{0y}^7 \mathbf{u}_y^\delta)\|^2$ are reduced to that of $\|\partial_x^l(\Phi_0^5 \mathbf{u}_y^\delta)\|^2$. By Lemma 5.2, we have

$$\|\partial_x^l(\Phi_0^5 \mathbf{u}_y^\delta)\|^2 \lesssim \|\Phi_0^5\|_{L^\infty}^2 \|\partial_x^l \mathbf{u}_y^\delta\|^2 + (\|\partial_x^l \Phi_0^5\|^2 + \|\partial_x^l \Phi_{0y}^5\|^2) (\|\mathbf{u}_y^\delta\|^2 + \|\mathbf{u}_{xy}^\delta\|^2),$$

which together with (5.22) and (5.24) in Lemma 5.7 gives $\|\partial_x^l(\Phi_0^5 \mathbf{u}_y^\delta)\|^2 \lesssim \tilde{E}_2 \tilde{E}_m$. Concerning the boundary integral, by the first equation in (2.29) and the second equation in (2.28), we can replace u_y and δv_y by $h_1 + (2 + b_3)\eta - \delta^2 v_x$ and by $-\delta u_x$, respectively, so that we obtain

$$|(\partial_x^l(\Phi_0^7 \mathbf{u}_y^\delta), \partial_x^l \mathbf{u}^\delta)_\Gamma| \lesssim |\Phi_0^7(2 + b_3)\eta|_m |\mathbf{u}^\delta|_m + (|\Phi_0^7 h_1|_{m-\frac{1}{2}} + \delta |\Phi_0^7 \mathbf{u}_x^\delta|_{m-\frac{1}{2}}) |\mathbf{u}^\delta|_{m+\frac{1}{2}}.$$

These terms can be treated by the estimate of J_8 and (5.19) and (5.20) in Lemma 5.6. Therefore, we obtain $K_{13} \leq (\epsilon + C_\epsilon \tilde{E}_2) \tilde{E}_m$. Thus (5.49) holds.

As for (5.50), it suffices to estimate

$$\begin{cases} K_{14} := \|\partial_x^k(\Phi_0^5 D_\delta^3 \tilde{\eta})\|^2, \\ K_{15} := \delta^{2i} \|\partial_x^k(\Phi_0^5 \partial_x^i \partial_y^j \mathbf{u}^\delta)\|^2 \quad \text{for } 0 \leq i + j \leq 2, j \neq 2. \end{cases}$$

By (5.53), (5.10) in Lemma 5.4, (5.11) in Lemma 5.5, and (5.22) and (5.23) in Lemma 5.7, we obtain $K_{14} \lesssim D_2 D_m$. By Lemma 5.2, we have

$$K_{15} \lesssim \|\Phi_0^5\|_{L^\infty}^2 \delta^{2i} \|\partial_x^{k+i} \partial_y^j \mathbf{u}^\delta\|^2 + (\|\partial_x^k \Phi_0^5\|^2 + \|\partial_x^k \Phi_{0y}^5\|^2) \delta^{2i} (\|\partial_x^i \partial_y^j \mathbf{u}^\delta\|^2 + \|\partial_x^i \partial_y^j \mathbf{u}_x^\delta\|^2),$$

which together with (5.22) and (5.24) in Lemma 5.7 gives $K_{15} \lesssim D_2 D_m$. Thus (5.50) holds.

As for (5.51), by the definition of \mathbf{F}_2 (see (3.15)) and using the third equation in (2.29), it suffices to estimate

$$\begin{cases} K_{16} := \delta \|\partial_x^k(\Phi_0^5 D_\delta^i \tilde{\eta}_t)\|^2 & \text{for } i = 1, 2, 3, \\ K_{17} := \delta \|\partial_x^k(\Phi_0^5 u_{ty})\|^2, \\ K_{18} := \delta \|\partial_x^k(\Phi_0^5 \mathbf{u}_t^\delta u_y)\|^2, \\ K_{19} := \delta^{2i+1} \|\partial_x^k(\Phi_0^6 \partial_x^i \mathbf{u}_t^\delta)\|^2 & \text{for } i = 0, 1, \\ K_{20} := \delta^3 \|\partial_x^k(\Phi_0^5 D_\delta^i \tilde{\eta}_{tt} \partial_y^j u)\|^2 & \text{for } (i, j) = (0, 0), (1, 0), (0, 1), \\ K_{21} := \delta^3 \|\partial_x^k(\Phi_0^5 D_\delta^i \tilde{\eta}_{tt} \mathbf{u}_x^\delta)\|^2, \\ K_{22} := \delta^{i+2} |(\partial_x^k(\Phi_0^7 \partial_x^{i+1} \partial_y^j \mathbf{u}_t^\delta), \partial_x^k \mathbf{u}_t^\delta)_\Omega| & \text{for } (i, j) = (1, 0), (0, 1), \\ K_{23} := \delta |(\partial_x^k(\Phi_0^7 u_{yy})_t, \partial_x^k \mathbf{u}_t^\delta)_\Omega|. \end{cases}$$

Here we did not list the terms which we have already estimated as K_1, \dots, K_5 . By (5.53), (5.8) in Lemma 5.4, (5.14) in Lemma 5.5, and (5.22) and (5.23) in Lemma 5.7, we obtain $K_{16} \lesssim \tilde{E}_2 \tilde{F}_m + \tilde{F}_2 \tilde{E}_m$. By Lemma 5.2, we have

$$K_{17} \lesssim \|\Phi_0^5\|_{L^\infty}^2 \delta \|\partial_x^k u_{ty}\|^2 + (\|\partial_x^k \Phi_0^5\|^2 + \|\partial_x^k \Phi_{0y}^5\|^2) \delta (\|u_{ty}\|^2 + \|u_{txy}\|^2),$$

which together with (5.22) and (5.24) in Lemma 5.7 gives $K_{17} \lesssim \tilde{E}_2 \tilde{F}_m + \tilde{E}_m \tilde{F}_2$. By Lemma 5.2, we have

$$\begin{aligned} K_{18} &\lesssim \|\Phi_0^5\|_{L^\infty}^2 \delta \|\mathbf{u}_t^\delta\|_{L^\infty}^2 \|\partial_x^k u_y\|^2 + \delta \|\mathbf{u}_t^\delta\|_{L^\infty}^2 (\|\partial_x^k \Phi_0^5\|^2 + \|\partial_x^k \Phi_y^5\|^2) (\|u_y\|^2 + \|u_{xy}\|^2) \\ &\quad + \|\Phi_0^5\|_{L^\infty}^2 \delta (\|\partial_x^k \mathbf{u}_t^\delta\|^2 + \|\partial_x^k \mathbf{u}_{ty}^\delta\|^2) (\|u_y\|^2 + \|u_{xy}\|^2), \end{aligned}$$

which together with the second inequality in (5.7) in Lemma 5.4 and (5.22) and (5.24) in Lemma 5.7 gives $K_{18} \lesssim \tilde{E}_m \tilde{F}_2 + \tilde{E}_2 \tilde{F}_m$. By (5.53), the second inequality in (5.7) in Lemma 5.4 and

(5.22) and (5.23) in Lemma 5.7, we obtain $K_{19} \lesssim \tilde{E}_2 \tilde{F}_m + \tilde{F}_2 \tilde{E}_m$. As for K_{20} , we will consider the case $(i, j) = (0, 1)$ only, because the other cases can be treated more easily. By Lemma 5.2, we have

$$\begin{aligned} K_{20} &\lesssim \|\Phi^5\|_{L^\infty}^2 \delta^3 \|\tilde{\eta}_{tt}\|_{L^\infty}^2 \|\partial_x^k u_y\|^2 + \delta^3 \|\tilde{\eta}_{tt}\|_{L^\infty}^2 (\|\partial_x^k \Phi^5\|^2 + \|\partial_x^k \Phi^5\|^2) (\|u_y\|^2 + \|u_{xy}\|^2) \\ &\quad + \|\Phi^5\|_{L^\infty}^2 \delta^3 (\|\partial_x^k \tilde{\eta}_{tt}\|^2 + \|\partial_x^k \tilde{\eta}_{tty}\|^2) (\|u_y\|^2 + \|u_{xy}\|^2), \end{aligned}$$

which together with (5.9) in Lemma 5.4 and (5.22) and (5.24) in Lemma 5.7 gives $K_{20} \lesssim \tilde{E}_2 \tilde{F}_m + \tilde{F}_2 \tilde{E}_m$. Similarly, we obtain $K_{21} \lesssim \tilde{E}_2 \tilde{F}_m + \tilde{F}_2 \tilde{E}_m$. As for K_{22} , integration by parts in x yields

$$\begin{aligned} K_{22} &= \delta^{i+2} |(\partial_x^k \{(\Phi_0^7 \partial_x^i \partial_y^j \mathbf{u}_t^\delta)_x - \Phi_{0x}^7 \partial_x^i \partial_y^j \mathbf{u}_t^\delta\}, \partial_x^k \mathbf{u}_t^\delta)_\Omega| \\ &\leq \delta^{i+2} |(\partial_x^k (\Phi_0^7 \partial_x^i \partial_y^j \mathbf{u}_t^\delta), \partial_x^k \mathbf{u}_{tx}^\delta)_\Omega| + \delta^{i+2} |(\partial_x^k (\Phi_{0x}^7 \partial_x^i \partial_y^j \mathbf{u}_t^\delta), \partial_x^k \mathbf{u}_t^\delta)_\Omega| \\ &\leq \epsilon \tilde{F}_m + C_\epsilon (\delta^{2i+1} \|\partial_x^k (\Phi_0^7 \partial_x^i \partial_y^j \mathbf{u}_t^\delta)\|^2 + \delta^{2i+3} \|\partial_x^k (\Phi_{0x}^7 \partial_x^i \partial_y^j \mathbf{u}_t^\delta)\|^2). \end{aligned}$$

Since the estimate of the right-hand side of the above inequality is reduced to those of K_{17} and K_{19} , we obtain $K_{22} \leq \epsilon \tilde{F}_m + C_\epsilon (\tilde{E}_2 \tilde{F}_m + \tilde{F}_2 \tilde{E}_m)$. As for K_{23} , integration by parts in y yields

$$\begin{aligned} K_{23} &= \delta |(\partial_x^k \{(\Phi_0^7 u_y)_y - \Phi_{0y}^7 u_y\}_t, \partial_x^k \mathbf{u}_t^\delta)_\Omega| \\ &\leq \delta |(\partial_x^k (\Phi_0^7 u_y)_t, \partial_x^k \mathbf{u}_{ty}^\delta)_\Omega| + \delta |(\partial_x^k (\Phi_0^7 u_y)_t, \partial_x^k \mathbf{u}_t^\delta)_\Gamma| + \delta |(\partial_x^k (\Phi_{0y}^7 u_y)_t, \partial_x^k \mathbf{u}_t^\delta)_\Omega| \\ &\leq \epsilon \tilde{F}_m + C_\epsilon (\delta \|\partial_x^k (\Phi_0^7 u_y)_t\|^2 + \delta \|\partial_x^k (\Phi_{0y}^7 u_y)_t\|^2) + \delta |(\partial_x^k (\Phi_0^7 u_y)_t, \partial_x^k \mathbf{u}_t^\delta)_\Gamma|. \end{aligned}$$

Here we can reduce the estimate of $\delta \|\partial_x^k (\Phi_0^7 u_y)_t\|^2 + \delta \|\partial_x^k (\Phi_{0y}^7 u_y)_t\|^2$ to those of K_4 and K_{17} . Moreover, by the first equation in (2.29), we can estimate the term $\delta |(\partial_x^k (\Phi_0^7 u_y)_t, \partial_x^k \mathbf{u}_t^\delta)_\Gamma|$ in the same way as the proof of (5.41) in Lemma 5.11. We thereby obtain $K_{23} \leq \epsilon \tilde{F}_m + C_\epsilon (\tilde{E}_2 \tilde{F}_m + \tilde{F}_2 \tilde{E}_m)$. Thus (5.51) holds.

As for (5.52), by the definition of \mathbf{G}_k (see (3.13)) we see that

$$\begin{aligned} \delta |(\mathbf{G}_k, \partial_x^k \mathbf{u}_t^\delta)_\Omega| &\leq \epsilon \tilde{F}_m + C_\epsilon \delta \|[\partial_x^k, A_5] \{(I + A_4) \nabla_\delta p_t + A_{4t} \nabla_\delta p\}\|^2 \\ &\quad + C_\epsilon \delta \|[\partial_x^k, A_{5t}] \mathbf{u}_t^\delta\|^2 + \delta |([\partial_x^k, A_5] \mathbf{F}_{3t}, \partial_x^k \mathbf{u}_t^\delta)_\Omega| \\ &=: \epsilon \tilde{F}_m + K_{24} + K_{25} + K_{26}. \end{aligned}$$

Here we can assume $k \geq 1$. By the fact that A_4 and A_5 are of the form Φ_0^7 (see (2.21) and (3.11)), Lemma 5.3, (5.5) in Lemma 5.4, and (5.22) and (5.24) in Lemma 5.7, we obtain

$$\begin{aligned} K_{24} &\leq C_\epsilon \{ \tilde{E}_2 (\delta \|\nabla_\delta \partial_x^{k-1} p_t\|^2 + \|\nabla_\delta \partial_x^{k-1} p\|^2) \\ &\quad + \tilde{E}_m (\delta \|\nabla_\delta p_t\|^2 + \delta \|\nabla_\delta p_{tx}\|^2 + \|\nabla_\delta p\|^2 + \|\nabla_\delta p_x\|^2) \}, \end{aligned}$$

which gives $K_{24} \leq C_\epsilon (\tilde{E}_2 \tilde{F}_m + \tilde{E}_m \tilde{F}_2)$. The estimate for K_{25} is reduced to that of K_{19} . Taking into account the explicit form of \mathbf{F}_3 (see (3.10)), we can estimate K_{26} in the same way as the proof of (5.51). Therefore the proof is complete. \square

By Lemmas 5.11 and 5.12, for the nonlinear term N_m defined by (3.30), we obtain the following proposition.

Proposition 5.13. *For any $\epsilon > 0$ there exists a positive constants C_ϵ such that the following estimate holds.*

$$N_m \leq \epsilon \tilde{F}_m + C_\epsilon (\tilde{E}_2 \tilde{F}_m + \tilde{F}_2 \tilde{E}_m + \varepsilon \sqrt{\tilde{E}_2 \tilde{E}_m}).$$

Moreover, if $\varepsilon \lesssim \delta$, then we have

$$N_m \leq \epsilon \tilde{F}_m + C_\epsilon (\tilde{E}_2 \tilde{F}_m + \tilde{F}_2 \tilde{E}_m).$$

Finally, we estimate the terms appearing in the right-hand side of (4.18) and (4.19) in Lemma 4.2. By the explicit form of g (see (4.2)), this consists of the terms in the form

$$\begin{cases} \Phi(\tilde{\eta}, D_\delta \tilde{\eta}, y) \delta \mathbf{u}_x^\delta u_y, \\ \Phi(\tilde{\eta}, D_\delta \tilde{\eta}, D_\delta^2 \tilde{\eta}, \mathbf{u}^\delta, y) w_\lambda \partial_y^j \mathbf{u}^\delta & \text{for } \lambda = 1, 2, j = 0, 1, \\ \Phi_0(\tilde{\eta}, D_\delta \tilde{\eta}, D_\delta^2 \tilde{\eta}, \mathbf{u}^\delta, \delta \mathbf{u}_x^\delta; y) \delta \mathbf{u}_x^\delta. \end{cases}$$

Lemma 5.14. *The following estimates hold.*

$$(5.54) \quad \begin{aligned} & \delta \|\partial_x^k g_x\|^2 + \delta \|\partial_x^k g_{0x}\|^2 + \delta \|\nabla_\delta \partial_x^k g_{0x}\|^2 \\ & + \delta \|\partial_x^k (N_6 \nabla_\delta p)_x\|^2 + \delta^2 \| |D_x|^{k+\frac{1}{2}} \phi_x |_0^2 \lesssim \tilde{F}_m + \tilde{F}_2 \tilde{E}_m, \end{aligned}$$

$$(5.55) \quad \begin{aligned} & \|\partial_x^k g\|^2 + \|\partial_x^k g_0\|^2 + \|\nabla_\delta \partial_x^k g_0\|^2 + \|\partial_x^k (N_6 \nabla_\delta p)\|^2 + \delta \| |D_x|^{k+\frac{1}{2}} \phi |_0^2 \\ & \lesssim (1 + D_2) D_m + \tilde{E}_2 \|\nabla_\delta \partial_x^k p\|^2 + \min\{\tilde{E}_m, D_m\} (\|\nabla_\delta p\|^2 + \|\nabla_\delta p_x\|^2), \end{aligned}$$

$$(5.56) \quad \begin{aligned} & \delta \|\partial_x^{l-1} g_t\|^2 + \delta \|\partial_x^{l-1} g_{0t}\|^2 + \delta \|\nabla_\delta \partial_x^{l-1} g_{0t}\|^2 \\ & + \delta \|\partial_x^{l-1} (N_6 \nabla_\delta p)_t\|^2 + \delta^2 \| |D_x|^{l-\frac{1}{2}} \phi_t |_0^2 \lesssim \tilde{F}_m + \tilde{F}_2 \tilde{E}_m. \end{aligned}$$

Proof. By Lemma 5.2, we have

$$\begin{aligned} \delta^3 \|\partial_x^k (\Phi^5 \mathbf{u}_{xx}^\delta u_y)\|^2 & \lesssim \|\Phi^5\|_{L^\infty}^2 \delta^3 \|\mathbf{u}_{xx}^\delta\|_{L^\infty}^2 \|\partial_x^k u_y\|^2 \\ & + \delta^3 \|\mathbf{u}_{xx}^\delta\|_{L^\infty}^2 (\|\partial_x^k \Phi^5\|^2 + \|\partial_x^k \Phi_y^5\|^2) (\|u_y\|^2 + \|u_{xy}\|^2) \\ & + \|\Phi^5\|_{L^\infty}^2 \delta^3 (\|\partial_x^k \mathbf{u}_{xx}^\delta\|^2 + \|\partial_x^k \mathbf{u}_{xxy}^\delta\|^2) (\|u_y\|^2 + \|u_{xy}\|^2), \end{aligned}$$

which together with the second inequality in (5.7) in Lemma 5.4 and (5.22) and (5.24) in Lemma 5.7, we obtain

$$\delta^3 \|\partial_x^k (\Phi^5 \mathbf{u}_{xx}^\delta u_y)\|^2 \lesssim \tilde{F}_2 \tilde{E}_m + \tilde{F}_m \tilde{E}_2.$$

It follows from (5.10) in Lemma 5.4 that $\|\mathbf{u}_x^\delta\|_{L^\infty}^2 \delta^3 \|\partial_x^k u_{xy}\|^2 \lesssim \tilde{E}_2 \tilde{F}_m$. Therefore, in the same way as the above estimate, we obtain

$$\delta^3 \|\partial_x^k (\Phi^5 \mathbf{u}_x^\delta u_{xy})\|^2 \lesssim \tilde{F}_2 \tilde{E}_m + \tilde{F}_m \tilde{E}_2.$$

These together with the estimates of K_3 , K_4 , and K_5 yield $\delta \|\partial_x^k g_x\|^2 \lesssim \tilde{F}_2 \tilde{E}_m + \tilde{E}_2 \tilde{F}_m$. It follows from the explicit form of g_0 (see (4.4)) that $\delta \|\partial_x^k g_{0x}\|^2 + \delta \|\nabla_\delta \partial_x^k g_{0x}\|^2 \lesssim \tilde{F}_m + \tilde{F}_2 \tilde{E}_m$, where we used the estimates for K_1, \dots, K_5 . By Lemma 5.2, we have

$$\begin{aligned} \delta \|\partial_x^{k+1} (N_6 \nabla_\delta p)\|^2 & \lesssim \|N_6\|_{L^\infty}^2 \delta \|\partial_x^{k+1} \nabla_\delta p\|^2 \\ & + \delta^2 (\|\partial_x^{k+1} N_6\|^2 + \|\partial_x^{k+1} N_{6y}\|) \delta^{-1} (\|\nabla_\delta p\|^2 + \|\nabla_\delta p_x\|^2). \end{aligned}$$

Since N_6 is the nonlinear part of A_6 , which is defined by (4.1), we see that N_6 is of the form Φ_0^7 . Thus by (5.22) and (5.24) in Lemma 5.7, we obtain

$$(5.57) \quad \delta \|\partial_x^{k+1} (N_6 \nabla_\delta p)\|^2 \lesssim \tilde{E}_2 \tilde{F}_m + \tilde{E}_m \tilde{F}_2.$$

The definition of ϕ (see (4.3)), Lemma 3.2, and (5.38) in Lemma 5.11 imply $\delta^2 \| |D_x|^{k+\frac{1}{2}} \phi_x |_0^2 \lesssim \tilde{F}_m + \tilde{F}_2 \tilde{E}_m$. Combining the above estimates, we obtain (5.54).

By Lemma 5.2, (5.10) in Lemma 5.4 and (5.22), and (5.24) in Lemma 5.7, we obtain

$$\begin{aligned} \delta^2 \|\partial_x^k(\Phi^5 \mathbf{u}_x^\delta u_y)\|^2 &\lesssim \|\Phi^5\|_{L^\infty}^2 \delta^2 \|\mathbf{u}_x^\delta\|_{L^\infty}^2 \|\partial_x^k u_y\|^2 \\ &\quad + \delta^2 \|\mathbf{u}_x^\delta\|_{L^\infty}^2 (\|\partial_x^k \Phi^5\|^2 + \|\partial_x^k \Phi_y^5\|^2) (\|u_y\|^2 + \|u_{xy}\|^2) \\ &\quad + \|\Phi^5\|_{L^\infty}^2 \delta^2 (\|\partial_x^k \mathbf{u}_x^\delta\|^2 + \|\partial_x^k \mathbf{u}_{xy}^\delta\|^2) (\|u_y\|^2 + \|u_{xy}\|^2) \\ &\lesssim D_2(1 + D_m). \end{aligned}$$

By (5.53), (5.10) in Lemma 5.4, and (5.22) and (5.23) in Lemma 5.7, we get $\delta^4 \|\partial_x^k(\Phi^5(\mathbf{u}_x^\delta)^2)\|^2 \lesssim D_2(1 + D_m)$. These together with the estimate of K_{15} yield $\|\partial_x^k g\|^2 \lesssim D_2(1 + D_m)$. By the estimate for K_{15} , we obtain $\|\partial_x^k g_0\|^2 + \|\nabla_\delta \partial_x^k g_0\|^2 \lesssim (1 + D_2)D_m$. In the same way as the proof of (5.57), we obtain

$$\|\partial_x^k(N_6 \nabla_\delta p)\|^2 \lesssim \tilde{E}_2 \|\nabla_\delta \partial_x^k p\|^2 + \min\{\tilde{E}_m, D_m\} (\|\nabla_\delta p\|^2 + \|\nabla_\delta p_x\|^2).$$

Lemma 3.2 and (5.40) in Lemma 5.11 lead to $\delta \| |D_x|^{k+\frac{1}{2}} \phi_0^2 \|^2 \lesssim (1 + D_2)D_m$. Combining the above estimates implies (5.55).

By Lemma 5.2, we have

$$\begin{aligned} \delta^3 \|\partial_x^{l-1}(\Phi^5 \mathbf{u}_{tx}^\delta u_y)\|^2 &\lesssim \|\Phi^5\|_{L^\infty}^2 \delta^3 \|\mathbf{u}_{tx}^\delta\|_{L^\infty}^2 \|\partial_x^{l-1} u_y\|^2 \\ &\quad + \delta^3 \|\mathbf{u}_{tx}^\delta\|_{L^\infty}^2 (\|\partial_x^{l-1} \Phi^5\|^2 + \|\partial_x^{l-1} \Phi_y^5\|^2) (\|u_y\|^2 + \|u_{xy}\|^2) \\ &\quad + \|\Phi^5\|_{L^\infty}^2 (\|u_y\|^2 + \|u_{xy}\|^2) \delta^3 (\|\partial_x^l \mathbf{u}_t^\delta\|^2 + \|\partial_x^l \mathbf{u}_{ty}^\delta\|), \end{aligned}$$

which together with the second inequality in (5.7) in Lemma 5.4 and (5.22) and (5.24) in Lemma 5.7 gives $\delta^3 \|\partial_x^{l-1}(\Phi^5 \mathbf{u}_{tx}^\delta u_y)\|^2 \lesssim \tilde{E}_2 \tilde{F}_m + \tilde{F}_2 \tilde{E}_m$. In a similar way, we get $\delta^3 \|\partial_x^{l-1}(\Phi^5 \mathbf{u}_t^\delta u_{xy})\|^2 \lesssim \tilde{E}_2 \tilde{F}_m + \tilde{F}_2 \tilde{E}_m$. Thus, in the same way as the proof of (5.54), we obtain (5.56). The proof is complete. \square

6 Proof of the main theorem

Summarizing the estimates in the last sections, we will prove the following proposition.

Proposition 6.1. *Let m be an integer satisfying $m \geq 2$, $0 < R_1 \leq R_0$, $0 < W_1 \leq W_2$, and $0 < \alpha \leq \alpha_0$, where R_0 and α_0 are constants in Propositions 3.3 and 3.6. There exist positive constants c_1 , C_5 , C_6 , and C_7 such that if the solution (η, u, v, p) of (2.28)–(2.30) and the parameters δ , ε , R , and W satisfy*

$$\tilde{E}_2(t) \leq c_1, \quad 0 < \delta, \varepsilon \leq 1, \quad R_1 \leq R \leq R_0, \quad W_1 \leq W \leq \delta^{-2} W_2,$$

then we have

$$(6.1) \quad \tilde{E}_2(t) \leq C_7 E_2(0) e^{C_6 \varepsilon t}, \quad \tilde{E}_m(t) + \int_0^t \tilde{F}_m(\tau) d\tau \leq C_7 E_m(0) \exp(C_5 E_2(0) e^{C_6 \varepsilon t} + C_5 \varepsilon t)$$

Moreover, if $\varepsilon \lesssim \delta$, then we have

$$\tilde{E}_2(t) \leq C_7 E_2(0), \quad \tilde{E}_m(t) + \int_0^t \tilde{F}_m(\tau) d\tau \leq C_7 E_m(0) \exp(C_5 E_2(0)).$$

In order to prove the above proposition, we prepare the following lemma.

Lemma 6.2. *Under the same assumptions of Proposition 6.1, for any integer k satisfying $0 \leq k \leq m$, the following estimates hold.*

$$(6.2) \quad \tilde{E}_m \lesssim E_m,$$

$$(6.3) \quad \tilde{F}_m \lesssim F_m + \tilde{F}_2 \tilde{E}_m,$$

$$(6.4) \quad \|(1 + |D_x|)^m \nabla_\delta p\|^2 \lesssim (1 + D_2)^2 D_m.$$

Proof. As for (6.2), by the definition of \tilde{E}_m (see (5.1)) and Poincaré's inequality, it suffices to show that for any $\epsilon > 0$ there exists a positive constant C_ϵ such that

$$(6.5) \quad \|\partial_x^k u_y\|^2 \leq \epsilon \tilde{E}_m + C_\epsilon (E_m + \tilde{E}_2 \tilde{E}_m).$$

Applying ∂_x^k to (2.28)–(2.30) and using the argument in the proof of Proposition 3.3, we obtain

$$\begin{aligned} \frac{1}{4K} \|\nabla_\delta \partial_x^k \mathbf{u}^\delta\|^2 \leq & - \left\{ \text{R} \delta (\partial_x^k \mathbf{u}^\delta, \partial_x^k \mathbf{u}_t^\delta)_\Omega + 2 \left(\frac{1}{\tan \alpha} \delta (\partial_x^k \eta, \partial_x^k \eta_t)_\Gamma + \frac{\delta^2 \mathbb{W}}{\sin \alpha} \delta (\partial_x^k \eta_x, \partial_x^k \eta_{tx})_\Gamma \right) \right\} \\ & + 4K (|\partial_x^k \eta|_0^2 + |\partial_x^k (b_3 \eta)|_0^2) + (\partial_x^k h_1, \partial_x^k u)_\Gamma - 2(\partial_x^k h_2, \delta \partial_x^k v)_\Gamma \\ & + 2 \left(\frac{1}{\tan \alpha} \partial_x^k \eta - \frac{\delta^2 \mathbb{W}}{\sin \alpha} \partial_x^k \eta_{xx}, \delta \partial_x^k h_3 \right)_\Gamma \\ & + \text{R} (\partial_x^k \mathbf{f}, \partial_x^k \mathbf{u}^\delta)_\Omega + (\partial_x^k \{-2A_4 \nabla_\delta p + (b_2 u_{yy}, 0)^T\}, \partial_x^k \mathbf{u}^\delta)_\Omega. \end{aligned}$$

Here we consider the case $k \geq 1$ only, because the case $k = 0$ can be treated more easily. Then, by Lemma 3.2 we obtain

$$\begin{aligned} \|\nabla_\delta \partial_x^k \mathbf{u}^\delta\|^2 \lesssim & E_m + |b_3 \eta|_m^2 + \delta^{-1} |(h_1, h_2)|_{m-\frac{1}{2}}^2 + \delta^2 |h_3|_m^2 + \delta^{-2} \|\partial_x^{k-1} \mathbf{f}\|^2 \\ & + |(\partial_x^k \{-2A_4 \nabla_\delta p + (b_2 u_{yy}, 0)^T\}, \partial_x^k \mathbf{u}^\delta)_\Omega|. \end{aligned}$$

It is easy to see that $|b_3 \eta|_m^2 + \delta^2 |h_3|_m^2 \lesssim E_m$. Combining these, (5.39) in Lemma 5.11, and (5.48) and (5.49) in Lemma 5.12, we obtain (6.5). Then, taking ϵ and c_1 sufficiently small we get (6.2).

As for (6.3), in view of the definition of \tilde{F}_m (see (5.2)), it suffices to show

$$(6.6) \quad \begin{aligned} & \delta^{-1} \|\nabla_\delta \partial_x^k p\|^2 + \delta \|\nabla_\delta \partial_x^k p_x\|^2 + \delta \|\nabla_\delta \partial_x^{k-1} p_t\|^2 \\ & + \delta^6 \| |D_x|^{k+\frac{7}{2}} \eta \|_0^2 + \delta \|(1 + \delta |D_x|)^{\frac{5}{2}} \partial_x^k \eta_t \|_0^2 \lesssim F_m + \tilde{E}_2 \tilde{F}_m + \tilde{F}_2 \tilde{E}_m. \end{aligned}$$

Combining Lemma 4.2, (5.37) in Lemma 5.11, (5.47) in Lemma 5.12, and (5.54) and (5.56) in Lemma 5.14, we obtain

$$(6.7) \quad \delta^{-1} \|\nabla_\delta \partial_x^k p\|^2 + \delta \|\nabla_\delta \partial_x^k p_x\|^2 + \delta \|\nabla_\delta \partial_x^{k-1} p_t\|^2 \lesssim F_m + \tilde{E}_2 \tilde{F}_m + \tilde{F}_2 \tilde{E}_m.$$

We proceed to estimate $(\delta^2 \mathbb{W})^2 \delta^2 \| |D_x|^{k+\frac{7}{2}} \eta \|_0^2$. Applying $-\delta |D_x|^{k+\frac{3}{2}}$ to the second equation in (2.29) and taking the inner product of $(\delta^2 \mathbb{W}) \delta |D_x|^{k+\frac{7}{2}} \eta$ with the resulting equality, we have

$$\begin{aligned} & \left(\frac{1}{\tan \alpha} \delta |D_x|^{k+\frac{3}{2}} \eta + \frac{\delta^2 \mathbb{W}}{\sin \alpha} \delta |D_x|^{k+\frac{7}{2}} \eta, (\delta^2 \mathbb{W}) \delta |D_x|^{k+\frac{7}{2}} \eta \right)_\Gamma \\ & = (\delta |D_x|^{k+\frac{3}{2}} (p - \delta v_y - h_2), (\delta^2 \mathbb{W}) \delta |D_x|^{k+\frac{7}{2}} \eta)_\Gamma, \end{aligned}$$

which together with Lemma 3.2 and the second equation in (2.28) leads to

$$\begin{aligned} & (\delta^2 \mathbb{W})^2 \delta^2 \| |D_x|^{k+\frac{7}{2}} \eta \|_0^2 \\ & \lesssim \delta^2 \| |D_x|^{\frac{1}{2}} \partial_x^k (p_x + \delta u_{xx} - h_{2x}) \|_0^2 \\ & \lesssim \delta \|\partial_x^k p_x\|^2 + \delta \|\partial_x^k \nabla_\delta p_x\|^2 + \delta^3 \|\partial_x^k u_{xx}\|^2 + \delta^3 \|\partial_x^k \nabla_\delta u_{xx}\| + \delta^2 \| |D_x|^{k+\frac{1}{2}} h_{2x} \|_0^2. \end{aligned}$$

Combining this, (5.38) in Lemma 5.11, and (6.7), we obtain the estimate for $(\delta^2 \mathbf{W})^2 \delta^2 \|D_x|^{k+\frac{7}{2}} \eta\|_0^2$. Finally, the estimate for $\delta \|(1 + \delta |D_x|)^{\frac{5}{2}} \partial_x^k \eta_t\|_0^2$ follows easily from the third equation in (2.29) and the estimate for $\delta^6 \|D_x|^{k+\frac{7}{2}} \eta\|_0^2$. Thus, we obtain (6.6). Then, taking c_1 sufficiently small we get (6.3).

As for (6.4), using (4.13) and (5.55) in Lemma 5.14 and taking c_1 sufficiently small, we have

$$\|\nabla_\delta \partial_x^k p\|^2 \lesssim (1 + D_2) D_m + \min\{\tilde{E}_m, D_m\} (\|\nabla_\delta p\|^2 + \|\nabla_\delta p_x\|^2).$$

Considering the case $m = 2$ and $k = 0, 1$ in the above inequality and taking c_1 sufficiently small yield $\|\nabla_\delta p\|^2 + \|\nabla_\delta p_x\|^2 \lesssim (1 + D_2) D_2$, which together with the above estimates gives (6.4). The proof is complete. \square

Proof of Proposition 6.1. Combining (3.31), Proposition 5.13, and (6.2) and (6.3) in Lemma 6.2 and taking ϵ and c_1 sufficiently small, we have

$$(6.8) \quad \frac{d}{dt} E_m(t) + \tilde{F}_m(t) \leq C_5 (\tilde{F}_2(t) + \epsilon) E_m(t)$$

for a positive constant C_5 independent of δ . Note that if $\epsilon \lesssim \delta$, then we can drop the term $C_5 \epsilon E_m(t)$ from the above inequality. Now, let us consider the case where $m = 2$. By taking c_1 sufficiently small, we have

$$\frac{d}{dt} E_2(t) + \tilde{F}_2(t) \leq C_6 \epsilon E_2(t)$$

for a positive constant C_6 independent of δ . Thus, Gronwall's inequality yields

$$(6.9) \quad E_2(t) + \int_0^t \exp(C_6 \epsilon(t - \tau)) \tilde{F}_2(\tau) d\tau \leq E_2(0) e^{C_6 \epsilon t}.$$

In particular, we have $\int_0^t \tilde{F}_2(\tau) d\tau \leq E_2(0) e^{C_6 \epsilon t}$. By this, (6.8), and Gronwall's inequality, we see that

$$\begin{aligned} E_m(t) + \int_0^t \tilde{F}_m(\tau) d\tau &\leq E_m(0) \exp\left(C_5 \int_0^t (\tilde{F}_2(\tau) + \epsilon) d\tau\right) \\ &\leq E_m(0) \exp(C_5 \tilde{E}_2(0) e^{C_6 \epsilon t} + C_5 \epsilon t). \end{aligned}$$

This together with (6.9) and (6.2) in Lemma 6.2 gives the desired estimates in Proposition 6.1. The proof is complete. \square

Proof of Theorem 2.2. Since the existence theorem of the solution locally in time is now classical, for example see [18, 15], it is sufficient to give a priori estimate of the solution. The first equation in (2.28) leads to

$$\delta^2 \|\partial_x^k \mathbf{u}_t^\delta\|^2 \lesssim \|\partial_x^k \mathbf{u}^\delta\|^2 + \|\nabla_\delta \partial_x^k \mathbf{u}^\delta\|^2 + \|\Delta_\delta \partial_x^k \mathbf{u}^\delta\|^2 + \|\nabla_\delta \partial_x^k p\|^2 + \|\partial_x^k \mathbf{f}\|^2.$$

Thus, by (5.50) in Lemma 5.12 and (6.4) in Lemma 6.2, we have $\delta^2 \|\partial_x^k \mathbf{u}_t^\delta\|^2 \lesssim (1 + D_2)^2 D_m$. By this, the third equation in (2.29), and the definitions of E_m and D_m (see (3.29) and (5.3)), we obtain

$$(6.10) \quad E_m(0) \leq C_8 (1 + D_2(0))^2 D_m(0)$$

for a positive constant C_8 independent of δ . Thus considering the case of $m = 2$ in the above inequality, taking $D_2(0)$ and T sufficiently small so that $2C_7 C_8 (1 + D_2(0))^2 D_2(0) \leq c_1$ and

$e^{C_6 T} \leq 2$, and using the first inequality in (6.1) in Proposition 6.1, we see that the solution satisfies

$$\tilde{E}_2(t) \leq c_1 \quad \text{for } 0 \leq t \leq T/\varepsilon.$$

Thus, using the second inequality in (6.1) in Proposition 6.1 together with (6.10), we obtain

$$(6.11) \quad \tilde{E}_m(t) + \int_0^t \tilde{F}_m(\tau) d\tau \leq C,$$

where the constant C depends on R_1, W_1, W_2, α , and M but not on δ, ε, R , nor W . By the first equation in (2.28), we easily obtain $\delta^{-1} \|(1 + |D_x|^m)(1 + \delta|D_x|)u_{yy}\|^2 \lesssim \tilde{F}_m$. Therefore, we obtain the desired estimate in Theorem 2.2. In view of the explicit form of \tilde{E}_m , using the second equation in (2.28) and Poincaré's inequality, we easily obtain (2.32). Moreover, in the case where $\mathbb{G} = \mathbb{T}, \varepsilon \lesssim \delta$, and $\int_0^1 \eta_0(x) dx = 0$, it follows from Poincaré's inequality that $\delta E_m(t) \lesssim F_m(t)$, which yields (2.33). The proof is complete. \square

References

- [1] R. W. Atherton and G. M. Homsy, On the derivation of evolution equations for interfacial waves, *Chem. Eng. Comm.*, **2** (1976), 57–77.
- [2] J. T. Beale, Large-time regularity of viscous surface waves, *Arch. Rational Mech. Anal.*, **84** (1984), 307–352.
- [3] T. B. Benjamin, Wave formation in laminar flow down an inclined plane, *J. Fluid Mech.*, **2** (1957), 554–574.
- [4] D. J. Benney, Long waves on liquid film, *J. Math. Phys.*, **45** (1966), 150–155.
- [5] D. Bresch and P. Noble, Mathematical justification of a shallow water model, *Methods Appl. Anal.*, **14** (2007), 87–117.
- [6] H. -C. Chang and E. A. Demekhin, Complex wave dynamics on thin films, *Studies in Interface Science*, 14, Elsevier Science B.V., Amsterdam, 2002.
- [7] R. V. Craster and O. K. Matar, Dynamics and stability of thin liquid films, *Rev. Mod. Phys.*, **81** (2009), 1131–1198.
- [8] B. Gjevik, Occurrence of finite-amplitude surface waves on falling liquid films, *Phys. Fluids*, **13** (1970), 1918–1925.
- [9] R. S. Johnson, Shallow water waves on a viscous fluid—The undular bore, *Phys. Fluids*, **15** (1972), 1693–1699.
- [10] S. Kalliadasis, C. Ruyer-Quil, B. Scheid, and M. G. Velarde, *Falling Liquid film*, Applied Mathematical Sciences, 176, Springer, London, 2012.
- [11] P. L. Kapitza, Wave flow in thin layers of a viscous fluid, *Zh. Eksp. Teor. Fiz.*, **19** (1948), 105–120 (Collected Works of P. L. Kapitza, Pergamon, Oxford, 1965).
- [12] S. P. Lin and M. V. G. Krishna, Stability of a liquid film with respect to initially finite three-dimensional disturbances, *Phys. Fluids*, **20** (1977), 2005–2011.

- [13] C. C. Mei, Nonlinear gravity waves in a thin sheet of viscous fluid, *J. Math. Phys.*, **45** (1966), 266–288.
- [14] C. Nakaya, Long waves on a thin fluid layer flowing down an inclined plane, *Phys. Fluids*, **18** (1975), 1407–1412.
- [15] T. Nishida, Y. Teramoto, and H. A. Win, Navier–Stokes flow down an inclined plane: downward periodic motion, *J. Math. Kyoto Univ.*, **33** (1993), 787–801.
- [16] A. Oron, S. H. Davis, and S. G. Bankoff, Long-scale evolution of thin liquid films, *Rev. Mod. Phys.*, **69** (1997), 931–980.
- [17] G. J. Roskes, Three-dimensional long waves on a liquid film, *Phys. Fluids*, **13** (1970), 1440–1445.
- [18] Y. Teramoto, On the Navier–Stokes flow down an inclined plane, *J. Math. Kyoto Univ.*, **32** (1992), 593–619.
- [19] Y. Teramoto and K. Tomoeda, Optimal Korn’s inequality for solenoidal vector fields on a periodic slab, *Proc. Japan Acad. Ser. A Math. Sci.*, **88** (2012), 168–172.
- [20] J. Topper and T. Kawahara, Approximate equations for long nonlinear waves on a viscous fluid, *J. Phys. Soc. Japan*, **44** (1978), 663–666.
- [21] H. Uecker, Self-similar decay of spatially localized perturbations of the Nusselt solution for the inclined film problem, *Arch. Rational Mech. Anal.*, **184** (2007), 401–447.
- [22] H. Ueno and T. Iguchi, A mathematical justification of a thin film approximation for the flow down an inclined plane, [arXiv:1506.08489](https://arxiv.org/abs/1506.08489).
- [23] C. S. Yih, Stability of parallel laminar flow with a free surface, *Proceedings of the Second U. S. National Congress of Applied Mechanics*, Ann Arbor, 1954, pp. 623–628. American Society of Mechanical Engineers, New York, 1955.
- [24] C. S. Yih, Stability of liquid flow down an inclined plane, *Phys. Fluids*, **6** (1963), 321–334.

Hiroki Ueno

Department of Mathematics, Faculty of Science and Technology, Keio University,
3-14-1 Hiyoshi, Kohoku-ku, Yokohama 223-8522, Japan.

E-mail: hueno@math.keio.ac.jp

Akinori Shiraishi

Former address: Department of Mathematics, Faculty of Science and Technology,
Keio University, 3-14-1 Hiyoshi, Kohoku-ku, Yokohama 223-8522, Japan.

Tatsuo Iguchi

Department of Mathematics, Faculty of Science and Technology, Keio University,
3-14-1 Hiyoshi, Kohoku-ku, Yokohama 223-8522, Japan.

E-mail: iguchi@math.keio.ac.jp