

First-principle study of the near-IR luminescence centers in $\text{Bi}_2\text{O}_3\text{-GeO}_2$ and $\text{Bi}_2\text{O}_3\text{-SiO}_2$ glasses

V. O. Sokolov,^{1,*} V. G. Plotnichenko,^{1,2} and E. M. Dianov¹

¹*Fiber Optics Research Center of the Russian Academy of Sciences
38 Vavilov Street, Moscow, 119333, Russia*

²*Moscow Institute of Physics and Technology
9 Institutskii per., Dolgoprudny, Moscow Region, 141700, Russia*

First-principle study of bismuth-related oxygen-deficient centers ($=\text{Bi}\cdots\text{Ge}\equiv$, $=\text{Bi}\cdots\text{Si}\equiv$, and $=\text{Bi}\cdots\text{Bi}=\text{ oxygen vacancies)$ in $\text{Bi}_2\text{O}_3\text{-GeO}_2$, $\text{Bi}_2\text{O}_3\text{-SiO}_2$, $\text{Bi}_2\text{O}_3\text{-Al}_2\text{O}_3\text{-GeO}_2$, and $\text{Bi}_2\text{O}_3\text{-Al}_2\text{O}_3\text{-SiO}_2$ hosts is performed. A comparison of calculated spectral properties of the centers with the experimental data on luminescence emission and excitation spectra suggests that luminescence in the 1.2 – 1.3 μm and 1.8 – 3.0 μm ranges in $\text{Bi}_2\text{O}_3\text{-GeO}_2$ glasses and crystals is likely caused by $=\text{Bi}\cdots\text{Ge}\equiv$ and $=\text{Bi}\cdots\text{Bi}=\text{ centers, respectively, and the luminescence near 1.1 } \mu\text{m}$ in $\text{Bi}_2\text{O}_3\text{-Al}_2\text{O}_3\text{-GeO}_2$ glasses and crystals may be caused by $=\text{Bi}\cdots\text{Ge}\equiv$ center with $(\text{AlO}_4)^-$ center in the second coordination shell of Ge atom.

I. INTRODUCTION

The IR luminescence of bismuth centers discovered in $\text{Al}_2\text{O}_3\text{-SiO}_2\text{:Bi}$ glasses [1, 2] has been observed in various glasses and crystals. Despite active studies of the bismuth-related IR luminescence (the present state of the art is reviewed in [3]) and successful applications for laser amplification and generation (see e.g. reviews [4] and [5]), the origin of the luminescence centers in most systems still remains to be established. In general, currently a belief is strengthened that certain subvalent bismuth species are responsible for the IR luminescence (see e.g. [3, 6, 7]). In a few systems the structure of the luminescence centers is definitively clear, namely, Bi_5^{3+} subvalent bismuth clusters in $\text{Bi}_5(\text{AlCl}_4)_3$ crystal, Bi_2^- dimers in $(\text{K-crypt})_2\text{Bi}_2$ crystal, Bi^+ ions in zeolite Y (see review [3] and references within for details). Models of subvalent bismuth centers as possible source of IR luminescence were suggested for several systems basing on first-principle modeling (e.g. [3] and references within; [8]).

Both for understanding the origin of IR luminescence centers and for possible applications, especially in fiber optics and optical communications, bismuthate-silicate and bismuthate-germanate systems are of interest. For many hosts, including GeO_2 and SiO_2 , Bi doping is hindered owing to significant ionic radius of bismuth. However in $\text{Bi}_2\text{O}_3\text{-GeO}_2$ or $\text{Bi}_2\text{O}_3\text{-SiO}_2$ glasses Bi_2O_3 appears as glass former and its content is known to vary in wide range (see e.g. [9, 10]). This shows promise of obtaining glasses with high concentration of the bismuth-related luminescence centers.

In $\text{GeO}_2\text{:Bi}$ and $\text{SiO}_2\text{:Bi}$ glasses containing 0.03–0.05 mol.% Bi_2O_3 and no other dopants, luminescence bands around 1.67 and 1.43 μm , respectively, were observed [11]. In [8] we suggested models of corresponding luminescence centers based on results of our first-

principle studies. In binary $\text{Bi}_2\text{O}_3\text{-GeO}_2$ systems, however, distinctly different luminescence occurs. The luminescence in the 1.2–1.3 μm range excited at 0.5, 0.8 and 1.0 μm was observed in $x\text{Bi}_2\text{O}_3\text{-(1-x)GeO}_2$ glasses ($0.1 \leq x \leq 0.4$ [12–15] and $x \approx 0.01$ [16]), in $\text{Bi}_{12}\text{GeO}_{20}$ crystals quenched in N_2 atmosphere [17], and in Mg- or Ca-doped $\text{Bi}_4\text{Ge}_3\text{O}_{12}$ crystals [18]. The luminescence in the 1.8–3 μm range was observed in $x\text{Bi}_2\text{O}_3\text{-(1-x)GeO}_2$ glasses ($x \gtrsim 0.2$) [14], in pure and Bi-, Mo-, or Mg-doped $\text{Bi}_4\text{Ge}_3\text{O}_{12}$ crystals, and in Mo-doped $\text{Bi}_{12}\text{GeO}_{20}$ crystals [15]. Annealing glasses in oxidative atmosphere [12–15] or adding oxidant (CeO_2) in glass [19] led to a decrease in the luminescence intensity evidencing convincingly oxygen-deficient character of the luminescence centers. In $\text{Bi}_2\text{O}_3\text{-Al}_2\text{O}_3\text{-GeO}_2$ glasses [20, 21], in $\text{Bi}_2\text{O}_3\text{-GeO}_2$ glass prepared in alumina crucible [16], and in $\text{Bi}_4\text{Ge}_3\text{O}_{12}\text{:Al}$ crystals [22] the 1.2–1.3 μm luminescence band contained a component near 1.1 μm characteristic of $\text{Al}_2\text{O}_3\text{-SiO}_2\text{-based}$ glasses [1, 2].

Whilst no specific models of the luminescence centers in $\text{Bi}_2\text{O}_3\text{-GeO}_2$ systems were suggested in the cited papers, the authors mainly held the opinion that such centers are formed by subvalent bismuth.

In all stable $\text{Bi}_2\text{O}_3\text{-GeO}_2$ and $\text{Bi}_2\text{O}_3\text{-SiO}_2$ crystals (silicites, $\text{Bi}_{12}\text{GeO}_{20}$ and $\text{Bi}_{12}\text{SiO}_{20}$, eulytines, $\text{Bi}_4\text{Ge}_3\text{O}_{12}$ and $\text{Bi}_4\text{Si}_3\text{O}_{12}$, benitoite, $\text{Bi}_2\text{Ge}_3\text{O}_9$) Bi atoms are known to be threefold coordinated [10]. It would be reasonable that Bi atoms occur mainly in the same local environment in $\text{Bi}_2\text{O}_3\text{-GeO}_2$ and $\text{Bi}_2\text{O}_3\text{-SiO}_2$ glasses as well. Such single threefold coordinated Bi atoms in GeO_2 and SiO_2 hosts were studied in our recent work [8]. If Bi_2O_3 content is high enough, the groups (pairs at least) of threefold coordinated Bi atoms bound together by bridging O atoms would occur in $\text{Bi}_2\text{O}_3\text{-GeO}_2$ and $\text{Bi}_2\text{O}_3\text{-SiO}_2$ as well. Therefore one might expect that in $\text{Bi}_2\text{O}_3\text{-GeO}_2$ and $\text{Bi}_2\text{O}_3\text{-SiO}_2$ glasses there are oxygen-deficient centers (ODC) not only typical for GeO_2 and SiO_2 (namely, O vacancy and twofold coordinated Si or Ge atoms), but as well similar ODCs containing Bi atoms (BiODCs), namely, $=\text{Bi}\cdots\text{Ge}\equiv$, $=\text{Bi}\cdots\text{Si}\equiv$, $=\text{Bi}\cdots\text{Bi}=\text{ vacancies and twofold coordi-$

* Corresponding author: vence.s@gmail.com

nated Bi atoms. According to [8], in SiO_2 twofold coordinated Bi atoms bound by bridging O atoms with Si atoms can be considered as Bi^{2+} centers, while in GeO_2 such Bi atoms are unstable. Thus, studying the $=\text{Bi}\cdots\text{Ge}\equiv$, $=\text{Bi}\cdots\text{Si}\equiv$, and $=\text{Bi}\cdots\text{Bi}=\text{vacancies}$ as possible BiODC in $\text{Bi}_2\text{O}_3\text{-GeO}_2$ and $\text{Bi}_2\text{O}_3\text{-SiO}_2$ is of interest.

II. THE MODELING OF BISMUTH-RELATED CENTERS

BiODCs of O vacancy type were studied, namely, $=\text{Bi}\cdots\text{Ge}\equiv$, $=\text{Bi}\cdots\text{Si}\equiv$ and $=\text{Bi}\cdots\text{Bi}=\text{vacancies}$ in $\text{Bi}_2\text{O}_3\text{-GeO}_2$ and $\text{Bi}_2\text{O}_3\text{-SiO}_2$ hosts, and $=\text{Bi}\cdots\text{Ge}\equiv$ and $=\text{Bi}\cdots\text{Si}\equiv$ vacancies in $\text{Al}_2\text{O}_3\text{-GeO}_2$ and $\text{Al}_2\text{O}_3\text{-SiO}_2$ hosts. The modeling was performed using periodical network models. $2 \times 2 \times 2$ supercells of GeO_2 and SiO_2 lattice of α quartz structure (24 GeO_2 or SiO_2 groups with 72 atoms in total) were chosen as models of initial perfect network. From two to eight GeO_2 (SiO_2) groups in the supercell were substituted by Bi_2O_3 groups, from one to four. So the supercell compositions varied from $\text{Bi}_2\text{O}_3 \cdot 22 \text{GeO}_2$ ($\text{Bi}_2\text{O}_3 \cdot 22 \text{SiO}_2$) to $4 \text{Bi}_2\text{O}_3 \cdot 16 \text{GeO}_2$ ($4 \text{Bi}_2\text{O}_3 \cdot 16 \text{SiO}_2$), respectively. Using ab initio molecular dynamics (MD) the system formed by supercells was heated to temperature as high as 1200 K (enough for both $\text{Bi}_2\text{O}_3\text{-GeO}_2$ and $\text{Bi}_2\text{O}_3\text{-SiO}_2$ [10]), maintained at this temperature until the equilibrium atom velocities distribution was reached and then cooled to 300 K. Periodical models of $\text{Bi}_2\text{O}_3\text{-GeO}_2$ and $\text{Bi}_2\text{O}_3\text{-SiO}_2$ networks based on final supercell configurations were applied to study the BiODCs. Each vacancy, $=\text{Bi}\cdots\text{Ge}\equiv$, $=\text{Bi}\cdots\text{Si}\equiv$, or $=\text{Bi}\cdots\text{Bi}=\text{vacancies}$, was formed by a removal of a proper O atom. When necessary, fourfold coordinated Al center, $(\text{AlO}_4)^-$, was formed substituting Al atom for Si or Ge atom and increasing the total number of electrons in the supercell by one. Equilibrium configurations of the BiODCs were found by a subsequent Car-Parrinello MD and complete optimization of the supercell parameters and atomic positions by the gradient method. All these calculations were performed using Quantum ESPRESSO package in the plane wave basis in generalized gradient approximation of density functional theory using ultra-soft projector augmented-wave pseudopotentials and Perdew-Burke-Ernzerhof functional. Configurations of the BiODCs obtained by this means then were used to calculate the absorption spectra. The calculations were performed with Elk code by Bethe-Salpeter equation method based on all-electron full-potential linearized augmented-plane wave approach in the local spin density approximation with Perdew-Wang-Ceperley-Alder functional. Spin-orbit interaction essential for Bi-containing systems was taken into account. Scissor correction was used to calculate transition energies. The scissor value was calculated using modified Becke-Johnson exchange-correlation potential. Further details and corresponding references may be found in [8].

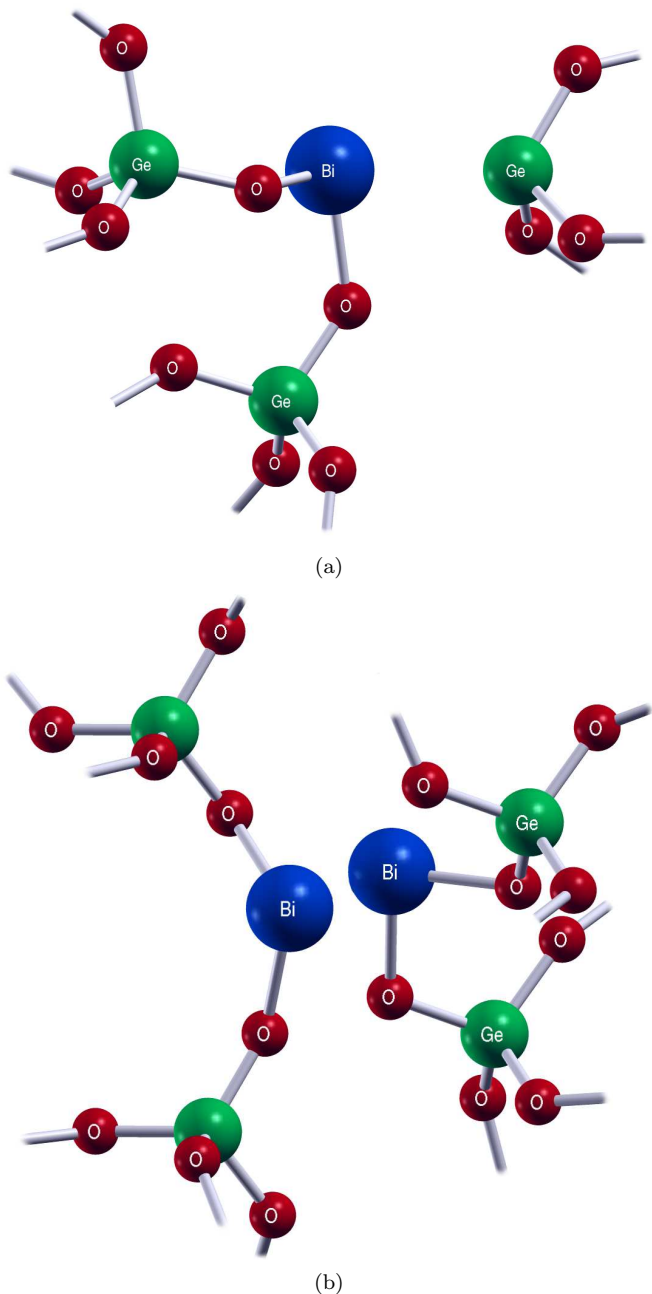

FIG. 1. BiODC in $\text{Bi}_2\text{O}_3\text{-GeO}_2$: (a) $=\text{Bi}\cdots\text{Ge}\equiv$; (b) $=\text{Bi}\cdots\text{Bi}=\text{vacancies}$.

On the contrary to the centers modeled in [8], the Stokes shift corresponding to a transition between the first excited state and the ground one turns out to be large in all the $=\text{Bi}\cdots\text{Ge}\equiv$, $=\text{Bi}\cdots\text{Si}\equiv$, and $=\text{Bi}\cdots\text{Bi}=\text{vacancies}$ centers. So in such centers the luminescence wavelengths were estimated only roughly.

Calculated configurations of $=\text{Bi}\cdots\text{Ge}\equiv$ and $=\text{Bi}\cdots\text{Bi}=\text{vacancies}$ centers in $\text{Bi}_2\text{O}_3\text{-GeO}_2$ are shown in Fig. 1. Configurations of the corresponding centers in SiO_2 , $\text{Al}_2\text{O}_3\text{-GeO}_2$, and $\text{Al}_2\text{O}_3\text{-SiO}_2$ are similar. Bi-Ge

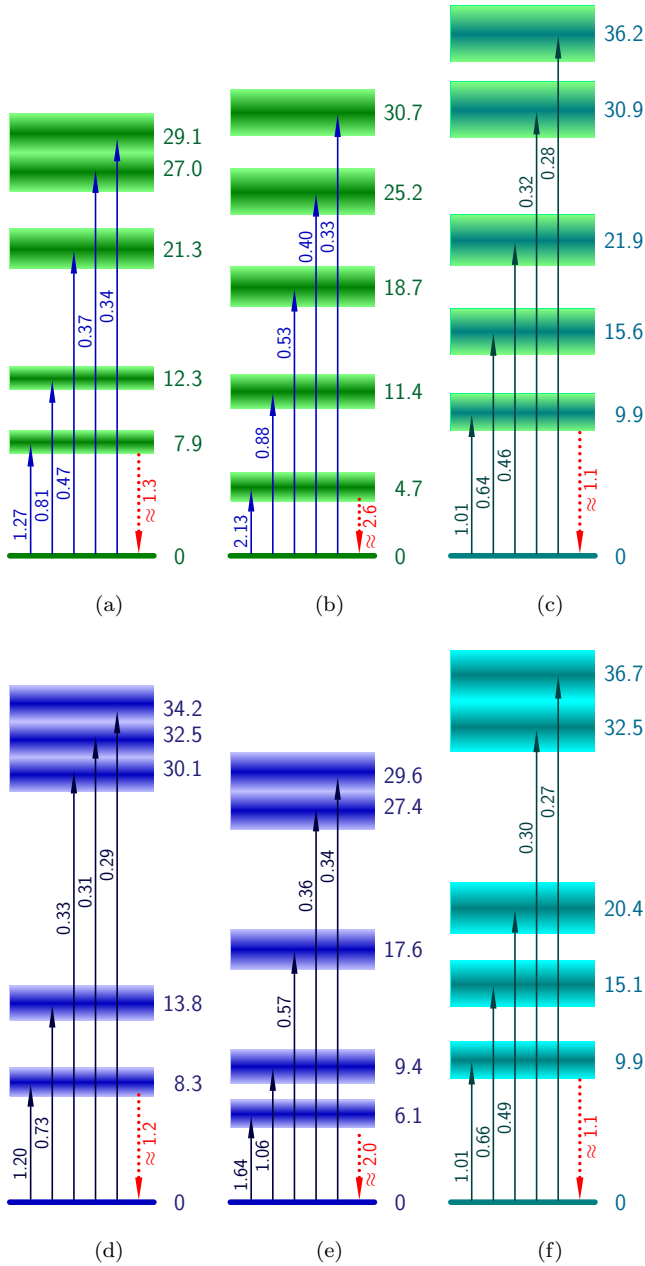

FIG. 2. BiODCs levels and transitions: (a) $=\text{Bi}\cdots\text{Ge}\equiv$ in GeO_2 ; (b) $=\text{Bi}\cdots\text{Bi}=\text{}$ in GeO_2 ; (c) $=\text{Bi}\cdots\text{Ge}\equiv$ in $\text{Al}_2\text{O}_3\text{-GeO}_2$; (d) $=\text{Bi}\cdots\text{Si}\equiv$ in SiO_2 ; (e) $=\text{Bi}\cdots\text{Bi}=\text{}$ in SiO_2 ; (f) $=\text{Bi}\cdots\text{Si}\equiv$ in $\text{Al}_2\text{O}_3\text{-SiO}_2$. Level energies are given in 10^3 cm^{-1} , transition wavelengths in μm .

distance in $=\text{Bi}\cdots\text{Ge}\equiv$ center is 3.08 \AA in GeO_2 and 3.12 \AA in $\text{Al}_2\text{O}_3\text{-GeO}_2$, Bi-Si distance in $=\text{Bi}\cdots\text{Si}\equiv$ center is found to be 2.89 \AA in SiO_2 and 2.95 \AA in $\text{Al}_2\text{O}_3\text{-SiO}_2$, Bi-Bi distance in $=\text{Bi}\cdots\text{Bi}=\text{}$ center in GeO_2 and SiO_2 is 3.03 \AA and 2.94 \AA , respectively. By comparison, calculated distance between Ge (Si) atoms in single $\equiv\text{Ge}-\text{Ge}\equiv$ ($\equiv\text{Si}-\text{Si}\equiv$) vacancy in GeO_2 (SiO_2) is found to be 2.58 \AA (2.44 \AA), and in Bi_2 dimer the Bi-Bi distance is known to be 2.66 \AA [23]. So

relatively weak covalent bond occurs between Bi and Ge (Si) atoms in $=\text{Bi}\cdots\text{Ge}\equiv$ ($=\text{Bi}\cdots\text{Si}\equiv$) vacancy and between two Bi atoms in $=\text{Bi}\cdots\text{Bi}=\text{}$ vacancy. Regardless of the presence of Al atom, the O-Bi-O angles in $=\text{Bi}\cdots\text{Ge}\equiv$ and $=\text{Bi}\cdots\text{Si}\equiv$ vacancies are close to the right angle, and the O-Ge-O angle in $=\text{Bi}\cdots\text{Ge}\equiv$ vacancy and the O-Si-O one in $=\text{Bi}\cdots\text{Si}\equiv$ vacancy are close to the tetrahedral angle. The analysis of electronic density has shown Bi to be nearly divalent in all the BiODCs under study. However the electronic structure of these BiODCs differs essentially from that of the divalent Bi centers (twofold coordinated Bi atoms) studied in [8]. In particular, in the latter the excited states energies are found to exceed $19 \times 10^3 \text{ cm}^{-1}$ (absorption wavelengths $\lesssim 0.55 \mu\text{m}$) [8], while in all $=\text{Bi}\cdots\text{Ge}\equiv$, $=\text{Bi}\cdots\text{Si}\equiv$, and $=\text{Bi}\cdots\text{Bi}=\text{}$ centers (Fig. 2) there are the low-lying excited states with the energy of $\lesssim 9.9 \times 10^3 \text{ cm}^{-1}$ (long-wave transitions in the $\gtrsim 1.1 \mu\text{m}$ range).

The origin of states and transitions in the $=\text{Bi}\cdots\text{Ge}\equiv$, $=\text{Bi}\cdots\text{Si}\equiv$, and $=\text{Bi}\cdots\text{Bi}=\text{}$ centers may be understood in a simple model considering twofold coordinated Bi atom as the divalent Bi center [8]. The ground state and the first excited state of Bi^{2+} ion are known to be $^2\text{P}_{1/2}$ and $^2\text{P}_{3/2}$ (20788 cm^{-1}), respectively [24]. In a crystal field two sublevels, $^2\text{P}_{3/2}(1)$ and $^2\text{P}_{3/2}(2)$, of the first excited state are formed, giving rise to the $^2\text{P}_{1/2} \rightarrow ^2\text{P}_{3/2}(1)$ and $^2\text{P}_{1/2} \rightarrow ^2\text{P}_{3/2}(2)$ absorption bands and the $^2\text{P}_{3/2}(1) \rightarrow ^2\text{P}_{1/2}$ luminescence band. The dangling bonds of twofold coordinated Bi atom and threefold coordinated Ge (Si) atom in $=\text{Bi}\cdots\text{Ge}\equiv$ ($=\text{Bi}\cdots\text{Si}\equiv$) center or the dangling bonds of two twofold coordinated Bi atoms in $=\text{Bi}\cdots\text{Bi}=\text{}$ center form bonding (doubly occupied) and anti-bonding (unoccupied) states. The corresponding levels calculated in the tight-binding model [25] without spin-orbit interaction for geometrical parameters of the centers, obtained in our modeling, are shown in Figs. 3(a) and (b) as (i) and (ii) schemes. Strong intra-atomic spin-orbit interaction in Bi^{2+} ion (the coupling constant is known to be $A \approx 13860 \text{ cm}^{-1}$ [24]) results in a splitting of both levels in accordance with Bi atom 6p states amplitudes in the wave functions ((iii) schemes in Figs. 3(a) and (b)); the values in brackets indicate total angular momentum of the Bi^{2+} ion states which provide Bi 6p contribution to the wave function of the level). And finally, level splitting in a crystal field together with Madelung's shift result in final sets of the electronic states ((iv) schemes in Figs. 3(a) and (b) according to the results of our modeling). The luminescence owing to transition from the lowest excited state to the ground state corresponds (regarding the 6p contributions to the wave functions) to the $^2\text{P}_{3/2}(1) \rightarrow ^2\text{P}_{1/2}$ transition in Bi^{2+} ion. However the transition energy turns out to be considerably decreased as a result of the above-described transformation of electronic states.

Both covalent (ii) and spin-orbit (iii) splittings are determined mainly by Bi-Ge(Si) (Bi-Bi) distances and mutual orientation of p orbital of Bi atom and sp^3 orbital

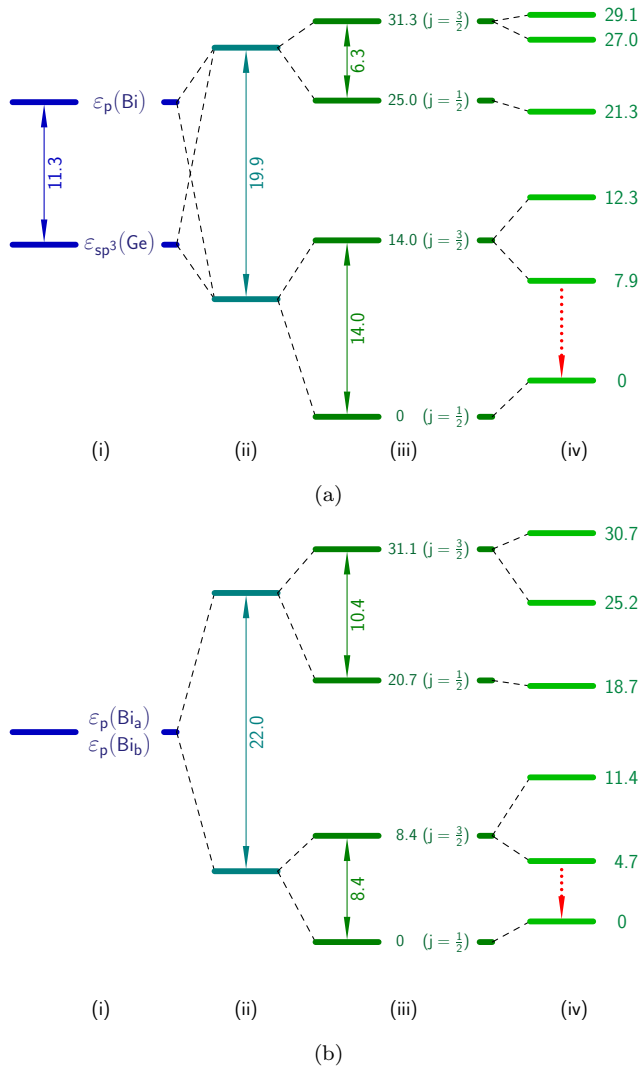

FIG. 3. On the origin of the electron states of BiODCs in GeO₂: (a) =Bi...Ge≡; (b) =Bi...Bi= (look text for details). Level energies and splittings are given in 10³ cm⁻¹.

of Ge (Si) atom (p orbitals of two Bi atoms). Hence the Stokes shift of the luminescence band relative to the absorption band corresponding to transitions between the ground and the first excited states cannot be small, as distinct from the monovalent Bi centers [8]. Basing on our calculations, the Stokes shift is estimated to be about 300 cm⁻¹ (~5%) for =Bi...Ge≡ and =Bi...Bi= centers in GeO₂ and =Bi...Si≡ centers in SiO₂, about 1200 cm⁻¹ (~20%) for the =Bi...Bi= center in SiO₂, and about 800 cm⁻¹ (~10%) for =Bi...Ge≡ center in Al₂O₃-GeO₂ and =Bi...Si≡ center in Al₂O₃-SiO₂ (Fig. 2).

If (AlO₄)⁻ center occurs in the second coordination shell of Ge (Si) atom of the =Bi...Ge≡ (=Bi...Si≡) center, the electronic density is displaced from the va-

cancy towards the Al atom leading to further attenuation of interaction between Bi and Ge (Si) atoms. As a result, Bi-Ge(Si) distance increases, covalent splittings (ii) is reduced, Bi 6p states contribution to the ground state wave function grows, and spin-orbit splitting (iv) increases. Thus, the electronic structure in the vicinity of Bi atom in the =Bi...Ge≡ (=Bi...Si≡) center becomes more similar to the electronic structure of twofold coordinated Bi atom. Accordingly, the IR transition is displaced to shorter-wave range (Figs. 2, (c) and (f)).

The formation energy of =Bi...Si≡, =Bi...Bi=, ≡Ge-Ge≡, and ≡Si-Si≡ vacancies was found to be approximately +0.8, -2.7, +0.9, and +3.1 eV, respectively (the formation energy of =Bi...Ge≡ vacancy is taken here to be zero point). Suggesting the migration energies of O vacancy between various pairs of atoms to be approximately in the same relations as formation energies of corresponding vacancies, one can explain the results of [14] by thermally stimulated migration of O vacancies during glass annealing. Owing to the migration, =Bi...Ge≡ centers may transform into =Bi...Bi= ones. As a result, 1.2-1.3 μm luminescence intensity decreases with 1.8-3 μm luminescence increasing.

III. CONCLUSION

In conclusion, the results of our modeling of BiODCs in Bi₂O₃-GeO₂ and Bi₂O₃-SiO₂ hosts make it reasonable to suggest that the luminescence in the 1.2-1.3 μm range in Bi₂O₃-GeO₂ glasses [12-14, 16, 19] and crystals [17, 18] is caused by =Bi...Ge≡ center, an O vacancy between Bi and Ge atoms (Fig. 1(a)). The luminescence in the 1.8-3 μm range observed in annealed Bi₂O₃-GeO₂ glasses [14] and in Bi₄Ge₃O₁₂ and Bi₁₂GeO₂₀ crystal [15] in the absence of the 1.2-1.3 μm luminescence may be caused by =Bi...Bi= center, an O vacancy between two Bi atoms (Fig. 1(b)). The decrease in intensity of the 1.2-1.3 μm luminescence may be explained by a transformation of =Bi...Ge≡ centers into =Bi...Bi= ones owing to thermally stimulated migration of O vacancies. The luminescence near 1.1 μm in Bi₂O₃-Al₂O₃-GeO₂ glasses [13, 16, 21] and in Al-doped Bi₄Ge₃O₁₂ crystals [22] may be caused by =Bi...Ge≡ center (AlO₄)⁻ center in the second coordination shell of Ge atom. Basing on our modeling, we suppose that in Bi-doped GeO₂ and SiO₂ glasses containing ≲ 0.1 mol.% Bi₂O₃ the IR luminescence centers are mainly interstitial Bi atoms forming complexes with ≡Ge-Ge≡ (≡Si-Si≡) vacancies [8], while in Bi₂O₃-GeO₂ (and probably Bi₂O₃-SiO₂) glasses containing ≳ 10 mol.% Bi₂O₃ the IR luminescence centers are mainly =Bi...Ge≡ (=Bi...Si≡) and =Bi...Bi= vacancies with Bi atoms bound in the glass network.

-
- [1] K. Murata, Y. Fujimoto, T. Kanabe, H. Fujita, and M. Nakatsuka, *Fusion Eng. Design* **44**, 437 (1999).
- [2] Y. Fujimoto and M. Nakatsuka, *Japan. J. Appl. Phys.* **40**, L279 (2001).
- [3] H.-T. Sun, J. Zhou, and J. Qiu, *Prog. Mater. Sci.* **64**, 12 (2014).
- [4] I. A. Bufetov and E. M. Dianov, *Laser Phys. Lett.*, **6**, 487 (2009).
- [5] E. M. Dianov, *J. Lightwave Technology* **31**, 681 (2013).
- [6] E. M. Dianov, *Quant. Electronics* **40**, 283 (2010).
- [7] M. Peng, G. Dong, L. Wondraczek, L. Zhang, N. Zhang, and J. Qiu, *J. Non-Cryst. Solids* **357**, 2241 (2011).
- [8] V. O. Sokolov, V. G. Plotnichenko, and E. M. Dianov, *Opt. Mater. Express* **3**, 1059 (2013).
- [9] F. Smet and W. J. P. van Enckevort, *J. Cryst. Growth* **100**, 417 (1990).
- [10] Yu. F. Kargin, V. I. Burkov, A. A. Mar'in, and A. V. Egorysheva, "*Crystals $Bi_{12}M_xO_{20+\delta}$ with the Sillenite Structure: Synthesis, Structure, and Properties*" (MFTI, Moscow, 2004).
- [11] S. V. Firstov, V. F. Khopin, I. A. Bufetov, E. G. Firstova, A. N. Guryanov, and E. M. Dianov, *Opt. Express* **19**, 19551 (2011).
- [12] X. Guo, H. J. Li, L. B. Su, P. S. Yu, H. Y. Zhao, J. F. Liu, and J. Xu, *Laser Phys.* **21**, 901 (2011).
- [13] X. Guo, H. Li, L. Su, P. Yu, H. Zhao, Q. Wang, J. Liu, and J. Xu, *Opt. Materials* **34**, 675 (2012).
- [14] X. Jiang, L. Su, X. Guo, H. Tang, X. Fan, Y. Zhan, Q. Wang, L. Zheng, H. Li, and J. Xu, *Opt. Lett.* **37**, 4260 (2012).
- [15] X. Jiang, L. Su, P. Yu, X. Guo, H. Tang, X. Xu, L. Zheng, H. Li, and J. Xu, *Laser Phys.* **23**, 105812 (2013).
- [16] A. A. Pynenkov, S. V. Firstov, A. A. Panov, E. G. Firstova, K. N. Nishchev, I. A. Bufetov, and E. M. Dianov, *Quant. Electronics* **43**, 174 (2013).
- [17] P. Yu, L. Su, H. Tang, X. Guo, H. Zhao, Q. Yang, and J. Xu, *Sci. China Technol. Sci.* **54**, 1287 (2011).
- [18] P. Yu, L. Su, and J. Xu, *Opt. Commun.* **304**, 19 (2013).
- [19] A. Winterstein, S. Manning, H. Ebindorff-Heidepriem, and L. Wondraczek, *Opt. Mater. Express* **2**, 1320 (2012).
- [20] M. Peng, J. Qiu, D. Chen, X. Meng, I. Yang, X. Jiang, and C. Zhu, *Opt. Lett.* **29**, 1998 (2004).
- [21] M. Peng, C. Wang, D. Chen, J. Qiu, X. Jiang, and C. Zhu, *J. Non-Cryst. Solids* **351**, 2388 (2005).
- [22] P. Yu, L. Su, X. Guo, and J. Xu, *J. Ceram. Soc. Japan* **120**, 265 (2012).
- [23] K. D. Huber and G. Herzberg, "*Constants of Diatomic Molecules*" (New York: Van Nostrand, 1979).
- [24] C. E. Moore, "*Atomic Energy Levels as Derived from the Analysis of Optical Spectra — Molybdenum through Lanthanum and Hafnium through Actinium*," in *Nat. Stand. Ref. Data Ser. 35, Vol. III* (Nat. Bur. Stand., 1971).
- [25] W. A. Harrison, "*Electronic Structure and Properties of Solids*" (San Francisco: Freeman, 1980).