

Cosmic String Dynamics and Evolution in Warped Spacetime

A. Avgoustidis

*Departament ECM and ICCUB, Universitat de Barcelona, Diagonal 647, 08028
Barcelona, Spain*

and

*DAMTP, CMS, University of Cambridge,
Wilberforce Road, Cambridge CB3 0WA, United Kingdom*
`tasos@ecm.ub.es`

ABSTRACT: We study the dynamics and evolution of Nambu-Goto strings in a warped spacetime, where the warp factor is a function of the internal coordinates giving rise to a ‘throat’ region. The microscopic equations of motion for strings in this background include potential and friction terms, which attract the strings towards the bottom of the warping throat. However, by considering the resulting macroscopic equations for the velocities of strings in the vicinity of the throat, we note the absence of enough classical damping to guarantee that the strings actually reach the warped minimum and stabilise there. Instead, our classical analysis supports a picture in which the strings experience mere deflections and bounces around the tip, rather than strongly damped oscillations. Indeed, 4D Hubble friction is inefficient in the internal dimensions and there is no other classical mechanism known, which could provide efficient damping. These results have potentially important implications for the intercommuting probabilities of cosmic superstrings.

KEYWORDS: cosmic strings, string cosmology.

Contents

1. Introduction	1
2. String Dynamics in Warped Spacetime	3
3. Effect of Warping on String Evolution: A Simple Model	4
4. IIB Compactifications	9
5. Discussion	16

1. Introduction

Recent progress in studying inflation in string theory and supergravity has led to a notable revival of interest in cosmic strings [1, 2, 3]. It is now believed that cosmic string formation is generic in both supersymmetric grand unified theories [4] and brane inflation [5, 6, 7], where the inflaton potential is of the hybrid type [8] and the inflationary phase ends with a phase transition, leaving behind a network of topological (or semilocal [9]) cosmic strings. Although such string networks cannot be solely responsible for the formation of the observed structure in the universe [10, 11], they can still act as subdominant contributors. Indeed, a recent study [12] finds that a Λ CDM model with a flat spectrum of scalar perturbations and a network of (field theory simulated) cosmic strings contributing to the Cosmic Microwave Background (CMB) anisotropy at the 10% level, provides an excellent fit to the observational data (see also Refs. [10, 11, 13, 14] for related work). On the other hand, significantly higher contribution from strings is inconsistent with the CMB, so, thinking on the positive side, one can use this fact to constrain the parameter space of inflationary models with network production. Perhaps more optimistically, one can hope to identify characteristic observational signatures of the string networks appearing in different models, and then try to look for them observationally, in an attempt to point out a direction towards the correct class of models.

From this point of view, brane inflation is of particular interest, being one of the most well-developed inflationary models in string theory, and also producing cosmic strings with distinct properties. Indeed, string networks in this setup evolve in a higher-dimensional space, and this can have important effects on the probability of string intercommutation [15, 16, 17] and on string velocities [18], resulting in a

significant enhancement of network string densities [19, 20]. Further, the networks produced in these scenarios are of the (p, q) -type [6, 7], and strings can interact in more complicated ways than ordinary Abelian cosmic strings, forming Y -shaped junctions. In the most well-developed models [21], the strings are evolving in a warped spacetime with one or more ‘throat’ regions, resulting from a combination of D -branes and fluxes present in the compactification. This warping gives rise to potentials for the string positions in the internal dimensions, so one expects that the strings get confined in a region around the bottom of the throat. However, this localisation process has not yet been studied in detail. The purpose of this paper is to study the dynamics and evolution of strings in the vicinity of such throat regions. What we find is that, although there are, indeed, potential terms pulling the strings towards the bottom of the throat, the classical evolution does not have enough (Hubble) friction to guarantee that they actually fall on it and stabilise there. Instead, depending on the impact parameter and velocity, a string can simply deflect, bounce and escape to infinity, enter a series of bounces, or form a bound orbit around the minimum. These possibilities can have important implications for the evolution of string networks, because the probability of string intercommutings is inversely proportional to the effective volume available to the string [16, 17]. Thus, if the strings are not confined at the bottom of the warping throat, this probability gets further suppressed leading to further enhancement in the network density.

The structure of the paper is as follows. In section 2, we consider the dynamics of strings evolving in a spacetime that is a warped product of a Friedmann-Lemaître-Robertson-Walker (FLRW) universe with a static toroidal space. We write down the Nambu-Goto equations of motion in this background and identify a number of potential and friction terms, which tend to pull the strings towards highly warped regions. In section 3, we use these equations to develop a model for studying a simple string configuration (one in which the strings are straight in the internal dimensions) moving near a minimum of the warping potential (section 3). We point out the weakness of Hubble friction and, choosing a simple warping function, we solve the model for different initial conditions obtaining a sample of string trajectories, which include deflections, bounces and bound orbits. In section 4 we try to make contact with more realistic IIB compactifications, by considering a slightly different setup, in which the metric is a warped product of Minkowski spacetime and an unspecified 6-dimensional Riemannian manifold. We perform a qualitative analysis in terms of one-dimensional motion in an effective potential, finding the same general types of orbits. We discuss the appearance of Hubble friction in this setup, in terms of cosmological expansion in the effective 4D theory, and comment on how the results of section 3 can be understood in this picture also. We summarise our results and discuss their implications for string evolution in section 5.

2. String Dynamics in Warped Spacetime

We start by considering a cosmic string propagating in a warped $(D+1)$ -dimensional FLRW spacetime with metric

$$ds^2 = g_{\mu\nu} dx^\mu dx^\nu = h^{-1/2}(\mathbf{1}) [N(t)^2 dt^2 - a(t)^2 d\mathbf{x}^2] - h^{1/2}(\mathbf{1}) b(t)^2 d\mathbf{l}^2, \quad (2.1)$$

where the warp factor h is a function of the internal coordinates $\mathbf{1}$. The motion of the string generates a two-dimensional timelike surface, the string worldsheet $x^\mu = x^\mu(\zeta^\alpha)$, parametrised by the worldsheet coordinates ζ^α , $\alpha = 0, 1$. The dynamics is given by the Nambu-Goto action

$$S = -\mu \int \sqrt{-\gamma} d^2\zeta, \quad (2.2)$$

where μ is the string tension and γ the determinant of $\gamma_{\alpha\beta} = g_{\mu\nu} \partial_\alpha x^\mu \partial_\beta x^\nu$, the pullback of the background metric (2.1) on the worldsheet. The action (2.2) enjoys 2D worldsheet diffeomorphism invariance, which can be used to fix the gauge by imposing two conditions on the worldsheet coordinates. For our discussion it will be convenient to work in the *transverse temporal gauge*:

$$\zeta^0 = t, \quad \dot{x}^\mu x'_\mu = 0, \quad (2.3)$$

where a dot (resp. prime) denotes differentiation with respect to the timelike (resp. spacelike) worldsheet coordinate ζ^0 (resp. ζ^1). This gauge choice imposes that \dot{x} is normal to the string, allowing an interpretation in terms of the physically relevant transverse string velocity, while identifying worldsheet and background times.

The equations of motion derived from the action (2.2) in this gauge are:

$$\frac{\partial}{\partial t} \left(\frac{\dot{x}^\mu x'^2}{\sqrt{-\gamma}} \right) + \frac{\partial}{\partial \zeta} \left(\frac{x'^\mu \dot{x}^2}{\sqrt{-\gamma}} \right) + \frac{1}{\sqrt{-\gamma}} \Gamma_{\nu\sigma}^\mu \left(x'^2 \dot{x}^\nu \dot{x}^\sigma + \dot{x}^2 x'^\nu x'^\sigma \right) = 0, \quad (2.4)$$

with μ, ν, σ running from 0 to D . In the following we shall use the notation:

$$\begin{aligned} \mu, \nu &= 0, 1, 2, \dots, D \\ i, j &= 1, 2, 3 & , \mathbf{x} \equiv x^i \\ \ell, m &= 4, 5, \dots, D & , \mathbf{1} \equiv x^\ell. \end{aligned} \quad (2.5)$$

The Christoffel symbols of the metric (2.1) are:

$$\begin{aligned} \Gamma_{00}^0 &= \frac{\dot{N}}{N} & \Gamma_{00}^i &= 0 & \Gamma_{00}^\ell &= -\frac{1}{4} N^2 \frac{h_{,\ell}}{b^2 h^2} \\ \Gamma_{0i}^0 &= 0 & \Gamma_{0j}^i &= \frac{\dot{a}}{a} \delta_j^i & \Gamma_{0i}^\ell &= 0 \\ \Gamma_{0\ell}^0 &= -\frac{1}{4} \frac{h_{,\ell}}{h} & \Gamma_{0\ell}^i &= 0 & \Gamma_{0m}^\ell &= \frac{\dot{b}}{b} \delta_m^\ell \\ \Gamma_{ij}^0 &= N^{-2} a \dot{a} \delta_{ij} & \Gamma_{jk}^i &= 0 & \Gamma_{ij}^\ell &= \frac{1}{4} \frac{a^2 h_{,\ell}}{b^2 h^2} \delta_{ij} \\ \Gamma_{\ell m}^0 &= h N^{-2} b \dot{b} \delta_{\ell m} & \Gamma_{\ell m}^i &= 0 & \Gamma_{mn}^\ell &= \frac{1}{4h} (\delta_{\ell m} h_{,n} + \delta_{\ell n} h_{,m} - \delta_{mn} h_{,\ell}) \\ \Gamma_{i\ell}^0 &= 0 & \Gamma_{j\ell}^i &= -\frac{1}{4} \frac{h_{,\ell}}{h} \delta_{ij} & \Gamma_{im}^\ell &= 0. \end{aligned} \quad (2.6)$$

We define a scalar ϵ , the string energy per unit coordinate length (per unit tension), by:

$$\epsilon = \frac{-x'^2}{\sqrt{-\gamma}} = \left(\frac{h^{-1/2}a^2\mathbf{x}'^2 + h^{1/2}b^2\mathbf{l}'^2}{h^{-1/2}N^2 - h^{-1/2}a^2\dot{\mathbf{x}}^2 - h^{1/2}b^2\dot{\mathbf{l}}^2} \right)^{1/2} \quad (2.7)$$

and note that due to the gauge choice $\gamma_{01} \equiv \dot{x}^\mu x'_\mu = 0$ we also have $\dot{x}^2/\sqrt{-\gamma} = \epsilon^{-1}$. With this notation, the 0, i and ℓ components of the equation of motion (2.4) become:

$$\dot{\epsilon} = -\epsilon \left\{ \frac{\dot{N}}{N} + \frac{a\dot{a}}{N^2} \left[\dot{\mathbf{x}}^2 - \left(\frac{\mathbf{x}'}{\epsilon} \right)^2 \right] + h \frac{b\dot{b}}{N^2} \left[\dot{\mathbf{l}}^2 - \left(\frac{\mathbf{l}'}{\epsilon} \right)^2 \right] - \frac{\mathbf{l} \cdot \nabla h(\mathbf{l})}{4h} \right\} \quad (2.8)$$

$$\begin{aligned} \ddot{\mathbf{x}} + \left\{ \frac{2\dot{a}}{a} - N^{-2} \left\{ N\dot{N} + a\dot{a} \left[\dot{\mathbf{x}}^2 - \left(\frac{\mathbf{x}'}{\epsilon} \right)^2 \right] + hb\dot{b} \left[\dot{\mathbf{l}}^2 - \left(\frac{\mathbf{l}'}{\epsilon} \right)^2 \right] \right\} \right\} \dot{\mathbf{x}} \\ + \frac{1}{4h} (\mathbf{l}' \cdot \nabla h(\mathbf{l})) \epsilon^{-2} \mathbf{x}' = \left(\frac{\mathbf{x}'}{\epsilon} \right)' \epsilon^{-1} \end{aligned} \quad (2.9)$$

$$\begin{aligned} \ddot{\mathbf{l}} + \left\{ \frac{2\dot{b}}{b} - N^{-2} \left\{ N\dot{N} + a\dot{a} \left[\dot{\mathbf{x}}^2 - \left(\frac{\mathbf{x}'}{\epsilon} \right)^2 \right] + hb\dot{b} \left[\dot{\mathbf{l}}^2 - \left(\frac{\mathbf{l}'}{\epsilon} \right)^2 \right] \right\} + 3 \frac{\mathbf{l} \cdot \nabla h(\mathbf{l})}{4h} \right\} \dot{\mathbf{l}} \\ - \frac{N^2 \nabla h(\mathbf{l})}{4b^2 h^2} + \frac{a^2 \nabla h(\mathbf{l})}{4b^2 h^2} (\dot{\mathbf{x}}^2 - \epsilon^{-2} \mathbf{x}'^2) - \frac{\nabla h(\mathbf{l})}{4h} (\dot{\mathbf{l}}^2 - \epsilon^{-2} \mathbf{l}'^2) \\ - \frac{1}{2h} (\mathbf{l} \cdot \nabla h(\mathbf{l})) \epsilon^{-2} \mathbf{l}' = \left(\frac{\mathbf{l}'}{\epsilon} \right)' \epsilon^{-1}. \end{aligned} \quad (2.10)$$

Comparing to the corresponding equations [18] in the unwarped case $h(\mathbf{l}) = 1$, one observes that the effect of warping is to introduce factors of h (in the \dot{b} terms) and new potential terms proportional to $\nabla h(\mathbf{l})$. This is in agreement with the intuitive expectation that, since energy is minimised at highly warped regions, there should be forces driving the string towards those regions. However, the dynamics by which this localisation mechanism may operate has not been studied in detail. The primary purpose of this paper is to explore the effect these potential terms may have on string evolution. In the next section we will study this problem by considering the relevant macroscopic velocity equations for simple warping potentials.

3. Effect of Warping on String Evolution: A Simple Model

In this section we shall study the effect of warping on the evolution of string networks, using a macroscopic velocity-dependent network model analogous to the models of Refs. [22, 23, 18]. The picture we have in mind is a network of strings produced at the end of brane inflation [24, 25, 26, 27, 28, 21]. Assuming that reheating is efficient, the strings can be taken to evolve in a radiation-dominated universe, but there is also a compact manifold of internal dimensions, which can have significant impact on the evolution of the network [15, 18, 16]. In explicit constructions [21], the metric is a warped product, and the warping factor is a function of the internal coordinates,

giving rise to ‘throats’ of local minima in the internal manifold. In this section we will consider a simplified situation in which the extra dimensions are toroidally compactified, so the metric is of the form (2.1). This will allow us to write down explicit evolution equations for the strings and obtain numerical solutions given a choice of warping factor.

The idea is to average the equations of motion (2.8)-(2.10) over a network of Nambu-Goto strings to obtain macroscopic evolution equations for the root-mean-squared (rms) velocities of string segments. Let us first consider the $\ddot{\mathbf{x}}$ equation (2.9). This differs from the corresponding unwarped spacetime equation [18] in two ways: first, there is a factor of h multiplying $b\dot{b}(\dot{\mathbf{l}}^2 - \mathbf{l}'^2\epsilon^{-2})$, and second, there is the new term:

$$\frac{1}{4h} (\mathbf{l}' \cdot \nabla h(\mathbf{l})) \epsilon^{-2} \mathbf{x}'.$$

For stabilised extra dimensions we have $\dot{b} = 0$, so the first of the above terms is zero in both unwarped and warped backgrounds. Further, in order to obtain the macroscopic velocity equation, one has to dot with $\dot{\mathbf{x}}$ and average over the string network, so the second term yields a contribution proportional to $\langle \mathbf{x}' \cdot \dot{\mathbf{x}} \rangle$, where the angled brackets denote ‘energy weighted averaging’ obtained by integrating over the worldsheet with weighting function ϵ , and normalising with respect to the total string energy. But, since the 3-vectors $\dot{\mathbf{x}}$ and \mathbf{x}' are uncorrelated, one expects $\langle \mathbf{x}' \cdot \dot{\mathbf{x}} \rangle$ to randomly change sign with no large-scale correlations as one moves along the string, and so this term gives zero when averaged over large scales. This has been tested numerically in the case of a 3+1 FLRW model in Ref. [18]. Finally, there is an implicit dependence on the warp factor through the modified definition of ϵ in equation (2.7), which, however, disappears when one moves to physical variables. Indeed, defining the rms (peculiar) string velocities:

$$v_x^2 = \left\langle \left(\frac{h^{-1/4} a d\mathbf{x}}{h^{-1/4} N dt} \right)^2 \right\rangle = \left\langle \left(\frac{d\mathbf{x}}{d\tau} \right)^2 \right\rangle \equiv \langle \dot{\mathbf{x}}^2 \rangle \quad (3.1)$$

and

$$v_\ell^2 = \left\langle \left(\frac{h^{1/4} b d\mathbf{l}}{h^{-1/4} N dt} \right)^2 \right\rangle = \left\langle \left(\frac{h^{1/2} b d\mathbf{l}}{a d\tau} \right)^2 \right\rangle \equiv \langle h b^2 \dot{\mathbf{l}}^2 / a^2 \rangle, \quad (3.2)$$

where ‘conformal’ time τ^1 corresponds to the slicing $N = a$, the evolution equation for the 3-dimensional velocity v_x in terms of the ‘proper’ time $ds = h^{-1/4} N dt$ is identical to that of the unwarped case, namely:

$$v_x \frac{dv_x}{ds} = \frac{k_x v_x}{R} (1 - v^2) - (2 - w_\ell^2) \frac{1}{a} \frac{da}{ds} (1 - v^2) v_x^2 - \frac{1}{a} \frac{da}{ds} v_\ell^2 v_x^2. \quad (3.3)$$

¹In this section we use the notation $\dot{\cdot} \equiv \frac{d}{d\tau}$.

Here, $v^2 = v_x^2 + v_\ell^2$ and w_ℓ is a string orientation parameter

$$w_\ell = \left\langle \frac{hb^2\mathbf{I}^2}{a^2\mathbf{x}'^2 + hb^2\mathbf{I}^2} \right\rangle^{1/2}, \quad (3.4)$$

quantifying the degree to which the strings lie in the extra dimensions \mathbf{l} . The 3-momentum parameter k_x is defined by

$$\frac{k_x v_x (1 - v^2)}{R} = \left\langle \dot{\mathbf{x}} \cdot \mathbf{u} \left(1 - \dot{\mathbf{x}}^2 - \frac{hb^2\dot{\mathbf{l}}^2}{a^2} \right) \right\rangle, \quad (3.5)$$

where \mathbf{u} is the physical curvature vector and R the average radius of curvature of the string network (see Ref. [18] for details).

We now consider the $\ddot{\mathbf{l}}$ equation (2.10). This contains several extra terms, some of which survive after averaging over the worldsheet. In particular there are terms proportional to $\nabla h(\mathbf{l})$, which can be thought of as a force driving the strings towards the minima of the warping potential. Indeed, for a static string configuration, the worldsheet action reduces to a potential² $V(\mathbf{l}) = \mu h^{-1/2}$ [16] and the corresponding force $F = -\nabla V(\mathbf{l})$ is proportional to $\nabla h(\mathbf{l}) h^{-3/2}$. An equation like (3.3) only yields information about the time evolution of the magnitude of the velocity but, here, we are also interested in its direction. We will thus seek to construct a vector equation for the internal velocities \mathbf{v}_ℓ .

For simplicity, we will choose a special configuration in which the strings are oriented normally to the extra dimensions, that is we will set $\mathbf{l}' = 0$. In this way we eliminate effects arising from string curvature in the extra dimensions (the right hand side of (2.10)) as well as corrections proportional to w_ℓ (see equation (3.3)), concentrating only on the effects of the warped background. One may worry that this choice could suppress effects that might be relevant in the following analysis, but it turns out that this is not the case. The effects of string bending in the extra dimensions have been studied in Refs. [18, 19] and, on macroscopic³ scales, can be described by a non-zero w_ℓ and an effective renormalisation of the string tension $\mu_{\text{eff}} > \mu$, both of which will not be important in the following. On the other hand, on small scales that are relevant in the present study, this bending can produce string velocities in the extra dimensions. However, these will simply add to string kinetic energies and can only strengthen our conclusions, which will be based on the absence of an efficient damping mechanism in these dimensions.

By concentrating on this special configuration $\mathbf{l}' = 0$, equation (2.10) simplifies considerably and this will allow us to study the dynamics of strings near a minimum of the warping potential [29]. We define the physical velocity in the extra dimensions as the $(D - 3)$ -vector

$$\mathbf{v}_\ell = h^{1/2} b \dot{\mathbf{l}} / a, \quad (3.6)$$

²There is also a dependence on the dilaton, which is ignored here (see later discussion).

³In this context ‘macroscopic’ refers to scales greater than the string correlation length.

which, due to the chosen string orientation, does not depend on the spacelike worldsheet coordinate ζ . Then, by forming $\dot{\mathbf{v}}_\ell$ and using the equations of motion (2.8), (2.10) we obtain:

$$\frac{d\mathbf{v}_\ell}{ds} = - \left[\frac{1}{a} \frac{da}{ds} (1 - 2v_x^2 - v_\ell^2) + \frac{\mathbf{v}_\ell \cdot \nabla h(\mathbf{l})}{4bh^{5/4}} \right] \mathbf{v}_\ell + (2 - 2v_x^2) \frac{\nabla h(\mathbf{l})}{4bh^{5/4}}. \quad (3.7)$$

We can use this equation to study the dynamics of a straight string moving in a warping potential $h(\mathbf{l})$. Fig. 1 shows the relevant phase diagram for two simple choices of warping potentials, namely $h(\mathbf{l}) = A - B \tanh^2(\mathbf{l})$ and $h(\mathbf{l}) = [A + B \ln(|\mathbf{l}|)]/\mathbf{l}^4$, in the simplest case of one extra dimension and assuming a constant 3-dimensional velocity v_x . As expected, the strings are driven towards the minimum of the potential at the centre, but the damping provided by Hubble expansion is too weak to guarantee that they actually reach it. Instead, equation (3.7) suggests a picture in which the string oscillates around the minimum, rather than quickly falling on it and stabilising. In view of the results of Ref. [18] this is not surprising: there, it was found that Hubble damping couples very weakly to the extra dimensional velocities and is generally insufficient to cause significant redshifting of velocities in the internal dimensions. This may seem to contradict the intuition one has from inflation, where oscillations of the inflaton around the minimum of the potential at the end of inflation are efficiently damped. Here the situation is similar, as the internal position of the string corresponds to a scalar field in four dimensions. However, unlike the case of inflation where cosmology is scalar field dominated and the damping is efficient, here the oscillations take place during radiation domination, so the damping term is much weaker and decays as t^{-1} (see Fig. 2).

Let us briefly discuss the effect of the 3-dimensional velocity v_x on the orbits of the string in $(\mathbf{l}, \mathbf{v}_\ell)$ phase-space. In the case of a single compact dimension ℓ , equation (3.7) reads:

$$\frac{dv_\ell}{ds} = - \frac{1}{a} \frac{da}{ds} (1 - 2v_x^2 - v_\ell^2) v_\ell + (2 - 2v_x^2 - v_\ell^2) \frac{\nabla h(\ell)}{4bh^{5/4}}, \quad (3.8)$$

where v_ℓ can also take negative values. Note that the first term, corresponding to Hubble damping, comes with a coefficient of $(1 - 2v_x^2 - v_\ell^2)$ which can be much smaller than 1 for $v_x^2 \lesssim 1/2$. The strength of this term depends on the magnitude of v_x and decays as t^{-1} as the universe expands. On the other hand, the potential term comes with a coefficient of $(2 - 2v_x^2 - v_\ell^2)$, which is always greater than unity due to the constraint $v^2 \leq 1/2$. This term is not diluted by cosmic expansion. The evolution is therefore dominated by this potential term but there is also a transient Hubble damping effect, which operates for a few Hubble times until it effectively dies away, and whose strength depends on the 3-dimensional velocity v_x (Fig. 3). It is therefore important to treat v_x as a dynamical variable rather than a constant parameter. Also, as we saw, the evolution of v_x is governed by equation (3.3), which depends

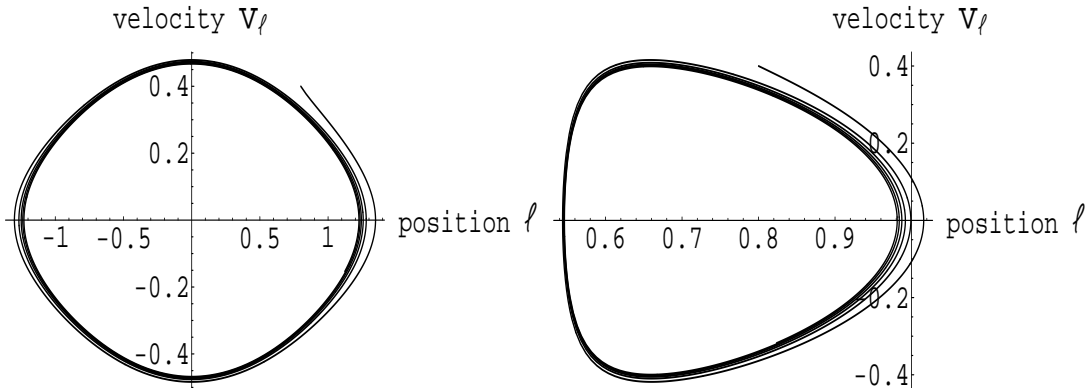

Figure 1: String trajectory in two-dimensional phase space (ℓ, v_ℓ) , i.e. in the case of a single extra dimension ℓ , assuming a constant 3D velocity v_x . The two plots correspond to different warping potentials, with warp factors $h(\ell) = A - B \tanh^2(\ell)$ (left) and $h(\ell) = [A + B \ln(|\ell|)]/\ell^4$ (right). Starting at a distance away from the potential minimum (located at $\ell = 0$ in the former case and $\ell = 0.8$ in the latter) and with initial velocity towards it, the string oscillates around the tip, but the motion is only weakly damped by Hubble expansion.

on v_ℓ , and thus the assumption of constant v_x is at best an approximation. We will therefore couple equation (3.8) to the evolution equation for the rms v_x , which, for the special orientation we chose ($w_\ell = 0$), becomes:

$$\frac{dv_x}{ds} = \frac{k_x}{R}(1 - v^2) - \frac{1}{a} \frac{da}{ds} (2 - 2v_x^2 - v_\ell^2)v_x. \quad (3.9)$$

This yields very interesting dynamics, with v_x exhibiting damped oscillations around its average value (Fig. 4). This effect, however, is too small to be of observational interest and is further suppressed by cosmic expansion. Initially, the string oscillates around the warped minimum, being (weakly) damped by Hubble expansion, while its 3-dimensional velocity v_x is modulated by the oscillation. After a few revolutions, the damping dies away and the phase-space orbit stabilises.

In this simplest case of a single extra extra dimension that we have studied so far, the string has to pass through the minimum in coordinate space in every cycle, but in the presence of more internal dimensions there will generally be a non-zero impact parameter. One naturally expects that angular momentum conservation will lead to deflecting/bouncing orbits around the tip of the warped throat. This will be studied in some detail in the next section. For now, we simply plot a sample of string trajectories (now in physical space), obtained by solving equations (3.7) and (3.9) in the case of two internal dimensions (Fig. 5). As shown, depending on the initial conditions, the string is deflected or bounces back, and can either escape from the throat or enter a series of bounces around the tip.

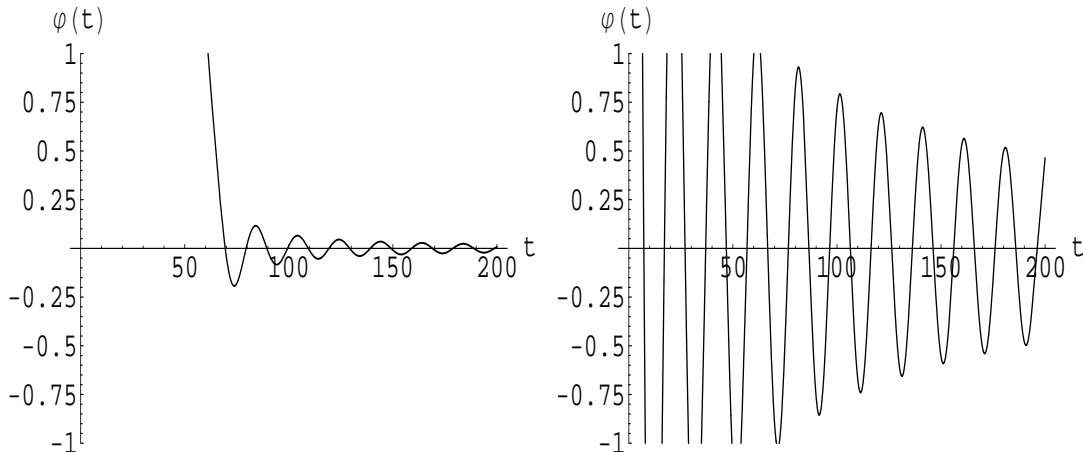

Figure 2: Effect of Hubble damping on scalar field oscillations $\varphi(t)$ in both scalar field dominated and radiation dominated cosmology. In the scalar field dominated case (left), Hubble damping has approximately constant magnitude, but in radiation domination (right) cosmological friction is much less efficient as it scales like t^{-1} . In the case of strings the situation is more dramatic, because the Hubble term also comes with a factor of $1 - 2v_x^2 - v_\ell^2$ (see equation (3.7)) and so, as 3D velocities evolve towards their scaling value, this term becomes zero.

The key point of this section, which is the central idea of the present paper, is that the classical evolution does not possess a strong damping term to guarantee that the strings quickly migrate to the tip of the warping throat and stabilise there. Instead, depending on the velocity and impact parameter, a string passing near a warped throat will generally experience a mere deflection or a bounce around the potential minimum. Note that, in the above, we have ignored any possible dependencies on the dilaton $\Phi(\mathbf{1})$. In the case of (p, q) -strings [7] for example, taking into account the dilaton dependence gives rise to a factor of $(p^2 + q^2 e^{-2\Phi(\mathbf{1})})^{1/2}$ [16] in the potential $V(\mathbf{1})$. This could lead to a dependence of the minimum on p and q , hence on the type of string, with potentially important implications for the intercommuting properties of different types of strings. However, for the strongly warped backgrounds one is usually interested in (e.g. [21]), the variation of the dilaton is negligible and thus we have safely ignored this effect in our discussion.

4. IIB Compactifications

In the previous section, we considered string motion in a background that was a warped product of an expanding FLRW universe with a compact internal manifold. Here, we would like to make contact with explicit constructions in string theory, in particular type IIB fluxed compactifications that have been used to realise cosmological inflation [21, 30, 31]. These typically involve a metric that is a warped

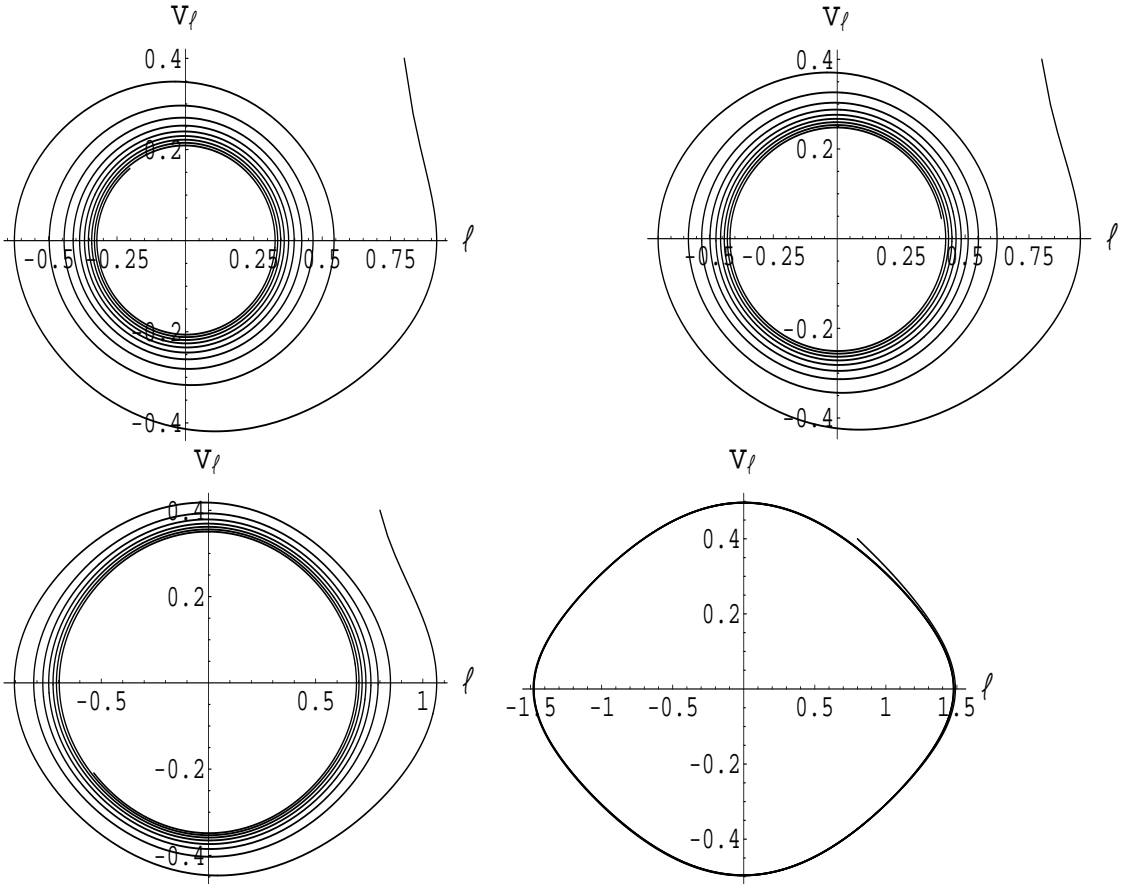

Figure 3: Effect of 3D velocity v_x on the orbits of the string in (ℓ, v_ℓ) phase space, for the case of one extra dimension ℓ . The warping factor is taken to be of the form $h(\ell) = A - B \tanh^2(\ell)$. Treating the 3D velocity as a constant parameter, each plot corresponds to a different value of v_x . From top left to bottom right: $v_x = 0, 0.3, 0.5$ and 0.64 . Clearly, as one increases v_x , Hubble damping becomes less and less important, since the coefficient of the friction term in equation (3.8) decreases. As a result, the orbit is more stable for larger values of v_x . To model this effect, the 3D velocity should be treated as a dynamical variable rather than a constant parameter.

product of Minkowski spacetime with a Calabi-Yau manifold, and time-dependence of the background arises in the effective 4D description. Indeed, in the effective theory, a number of scalar fields appear, which can couple to the 4D metric. In the constructions of [21, 31], all scalar fields are dynamically stabilised apart from one, corresponding to the position of a mobile D -brane in the 10D picture, which plays the role of the inflaton in the effective theory.

The Einstein frame metric takes the following general form:

$$ds^2 = h^{-1/2}(\ell) \eta_{\mu\nu} dx^\mu dx^\nu - h^{1/2}(\ell) g_{\ell m} d\ell^\ell d\ell^m, \quad (4.1)$$

where $\eta_{\mu\nu}$ is the 4D Minkowski metric and $g_{\ell m}$ the metric on the internal Calabi-Yau space. The warp factor h depends only on the internal coordinates ℓ . Explicit

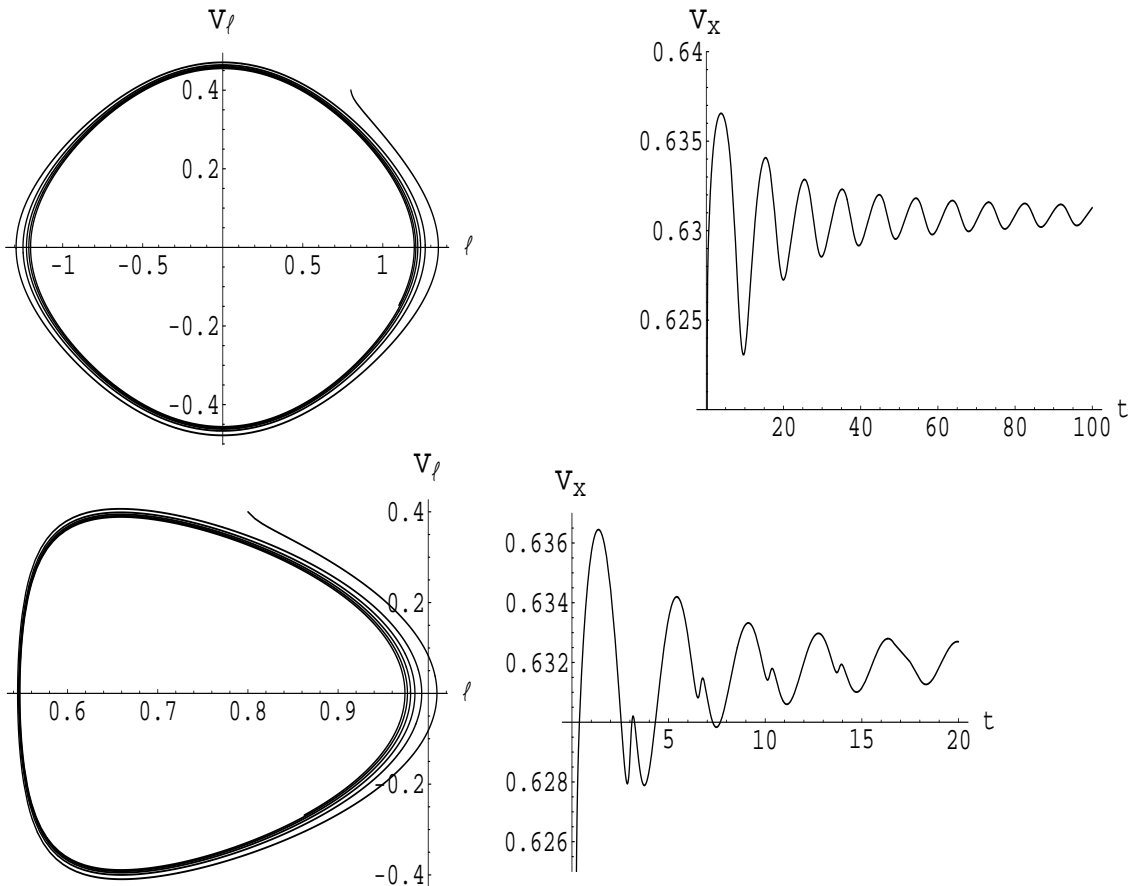

Figure 4: String trajectories (left) near the warped minimum in two-dimensional phase space (ℓ, v_ℓ) for the same warping potentials and initial conditions as in Fig. 1, but now treating v_x as a dynamical variable. The 3D velocity v_x oscillates due to its coupling to v_ℓ (see equation (3.9)), but this effect is small (right). The upper plots are for warping factor $h(\ell) = A - B \tanh^2(\ell)$, while the lower ones for $h(\ell) = [A + B \ln(|\ell|)]/\ell^4$.

solutions of this type exist, for example Klebanov-Tseytlin (KT) [32] and Klebanov-Strassler (KS) [33] geometries, but, for the general discussion that follows, we leave the exact geometry unspecified. We will assume, however, as in the above solutions, that the internal manifold has a group of angular symmetries allowing us to define a radial coordinate $r \equiv l'$, and that the warp factor h depends only on this radial coordinate.

A moving string on this warped background is described by the Nambu-Goto action (2.2) with metric (4.1). The motion of D -branes in warped backgrounds has been well-studied [34, 35, 36, 37]. The solutions found in those cases include deflections, bounces, and bound orbits, like in the previous section. Unlike the case of $D3$ -branes, which are spacetime-filling and only have velocities in the internal space, strings are rather different, as there are also two transverse directions where the string can move, giving rise to 3D velocities that can dynamically interfere with

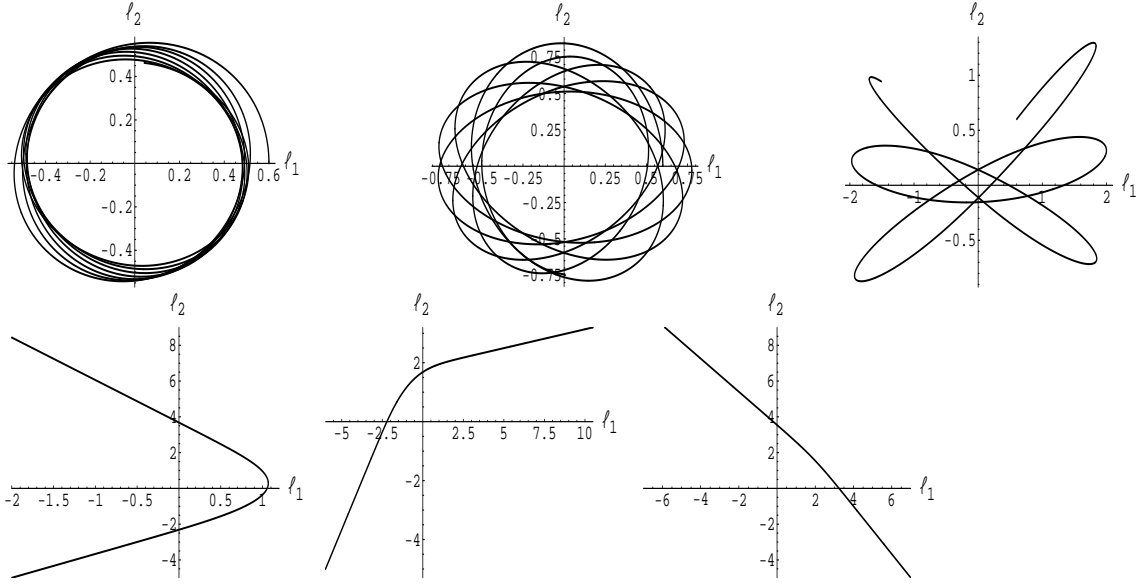

Figure 5: A sample of string trajectories in physical space, in the case of two extra dimensions ℓ_1 and ℓ_2 . Different trajectories correspond to different initial conditions for the position $\mathbf{l} = (\ell_1, \ell_2)$ and velocity $\mathbf{v}_\ell = (v_{\ell_1}, v_{\ell_2})$. In all cases the warping factor is $h(\mathbf{l}) = A - B \tanh^2(|\mathbf{l}|)$. The possibilities (depending on the initial conditions) include deflections, bounces and bound orbits with negligible Hubble friction.

the internal ones (see previous section). We consider this case in more detail below.

Defining the radial direction $r \equiv l^r$, we write the internal metric as:

$$g_{\ell m} dl^\ell dl^m = g_{rr} dr^2 + g_{\theta\phi} dl^\theta dl^\phi, \quad (4.2)$$

where the indices θ and ϕ run over the angular internal coordinates. The internal speed of the string is then $\dot{l}^2 = g_{rr} \dot{r}^2 + g_{\theta\phi} \dot{l}^\theta \dot{l}^\phi$, and the action, in the transverse temporal gauge, reads:

$$S = -\mu \int h^{-1/2}(r) \sqrt{\left[1 - \dot{\mathbf{x}}^2 - h(r)(g_{rr} \dot{r}^2 + g_{\theta\phi} \dot{l}^\theta \dot{l}^\phi)\right]} (\mathbf{x}'^2 + h(r) g_{\ell m} l'^\ell l'^m) d^2 \zeta. \quad (4.3)$$

As in the previous section, we will consider the special configuration in which the string has $l' = 0$. As we have chosen the angular coordinates l^ϕ to correspond to spacelike Killing vectors, the following momenta are conserved:

$$\pi_\phi \equiv \frac{\partial \mathcal{L}}{\partial \dot{l}^\phi} = \frac{\mu \sqrt{\mathbf{x}'^2}}{\sqrt{1 - \dot{\mathbf{x}}^2 - h(r)(g_{rr} \dot{r}^2 + g_{\theta\omega} \dot{l}^\theta \dot{l}^\omega)}} h^{1/2}(r) g_{\phi\theta} \dot{l}^\theta. \quad (4.4)$$

Also, time translational invariance implies that the energy

$$\mathcal{E} \equiv \mathbf{p} \cdot \dot{\mathbf{x}} + \rho \dot{r} + \pi_\phi \dot{l}^\phi - \mathcal{L} = \frac{\mu h^{-1/2}(r) \sqrt{\mathbf{x}'^2}}{\sqrt{1 - \dot{\mathbf{x}}^2 - h(r)(g_{rr} \dot{r}^2 + g_{\theta\phi} \dot{l}^\theta \dot{l}^\phi)}} \quad (4.5)$$

is conserved, where \mathbf{p} and ρ are the canonical momenta associated to \mathbf{x} and r respectively. Then, defining

$$\Pi^2(r) \equiv g^{\theta\phi} \pi_\theta \pi_\phi, \quad (4.6)$$

we can write

$$\mathcal{E} = \mu \sqrt{\mathbf{x}'^2} h^{-1/2}(r) \left(\frac{1 + \Pi^2(r)/\mu^2 \mathbf{x}'^2}{1 - \dot{\mathbf{x}}^2 - h(r) g_{rr} \dot{r}^2} \right)^{1/2}, \quad (4.7)$$

or equivalently:

$$\dot{r}^2 = \frac{g^{rr}}{h(r)} \left[1 - \left(\frac{\mu^2 \mathbf{x}'^2 + \Pi^2(r)}{h(r) \mathcal{E}^2} + \dot{\mathbf{x}}^2 \right) \right]. \quad (4.8)$$

For the setup we are interested in, the strings are macroscopic in the Minkowskian directions and homogeneous over the short length-scales relevant to the warping scale in the internal dimensions. Further, as we saw in the previous section, the coupling between 3D and internal velocities is weak, so one could take constant $\dot{\mathbf{x}}^2$ as an approximation. Here, we will consider the special case of a straight string $\mathbf{x}'^2 = 1$. Translational invariance along the transverse string directions implies that the corresponding momenta \mathbf{p} are conserved, and we can write:

$$\dot{r}^2 = \frac{g^{rr}}{h(r)} \left(1 - \frac{\mu^2 + \Pi^2(r) + h(r) \mathbf{p}^2}{h(r) \mathcal{E}^2} \right). \quad (4.9)$$

The right-hand-side is a function of the radial coordinate only, and so equation (4.9) describes the one-dimensional motion of a particle in an effective potential

$$\dot{r}^2 + V_{\text{eff}}(r) = 0, \quad (4.10)$$

where $V_{\text{eff}}(r)$ is minus the right-hand-side of (4.9). Physical motion is restricted to regions where $V_{\text{eff}} \leq 0$, and the zeros of the effective potential correspond to turning points, where the string reverses its (radial) direction of motion.

Let us first consider the case $\Pi^2(r) = \mathbf{p}^2 = 0$. The effective potential is as in Ref. [34], where the dynamics of D -branes moving in the vicinity of $NS5$ -branes has been analysed and explicit solutions have been obtained for $h(r) = 1 + c/r^2$, $c = \text{const}$. The motion is restricted to the region:

$$h(r) \geq \frac{\mu^2}{\mathcal{E}^2}. \quad (4.11)$$

Since $h(r \rightarrow \infty) = 1$, for $\mu < \mathcal{E}$ the constraint is empty and the string can escape to infinity. On the other hand, if $\mu > \mathcal{E}$ the string does not have enough energy to escape the potential, so it will reach a finite maximum distance, where $V_{\text{eff}} = 0$, and then reverse its motion to return to $r=0$.

Now consider non-zero angular momentum, $\Pi^2(r) > 0$, in which case the effective potential is:

$$V_{\text{eff}} = \frac{g^{rr}}{h(r)} \left(\frac{\mu^2 + \Pi^2(r)}{h(r) \mathcal{E}^2} - 1 \right). \quad (4.12)$$

There is now a new possibility in the case $\mathcal{E} > \mu$: since $\Pi^2(r)$ scales with the inverse metric (see equation (4.6)), the angular momentum increases as the string approaches the potential minimum and can dominate over the tension term at short distances. The effect of the angular momentum is to reduce the radial velocity of the string, until it reaches $V_{\text{eff}} = 0$, where it bounces and then escapes to infinity. For $\mathcal{E} < \mu$, the string does not have enough energy to escape the attractive potential, and at large enough distances the effective potential approaches a constant value:

$$V_{\text{eff}} \simeq g^{rr} \left(\frac{\mu^2}{\mathcal{E}^2} - 1 \right). \quad (4.13)$$

The string reaches a maximum distance and then returns to $r = 0$. The angular momentum generally slows down the approach to $r = 0$, and solutions include examples where the string spirals an infinite amount of times before reaching the potential centre [34]. Bound orbits can also exist, depending on the structure of $h(r)$. Indeed, bound orbits were found in the case of KT and KS backgrounds in Ref. [37], where $D3$ -brane motion was studied in detail using the Dirac action, and including the relevant Wess-Zumino term.

Let us finally focus on the 3D momenta \mathbf{p}^2 . These have the effect of ‘renormalising’ the second term in equation (4.12) by a correction of $\mathbf{p}^2/\mathcal{E}^2 = \dot{\mathbf{x}}^2 \equiv v_x^2$, that is:

$$V_{\text{eff}} = \frac{g^{rr}}{h(r)} \left[\frac{\mu^2 + \Pi^2(r)}{h(r)\mathcal{E}^2} - (1 - v_x^2) \right]. \quad (4.14)$$

In other words, some of the kinetic energy of the string is in the transverse motion in the Minkowskian directions, so it is harder for the string to escape to infinity. At large r the effective potential approaches

$$V_{\text{eff}} \simeq g^{rr} \left[\frac{\mu^2}{\mathcal{E}^2} - (1 - v_x^2) \right], \quad (4.15)$$

and so the string needs to have an energy greater than the relativistic mass, $\mathcal{E}^2 > \mu^2/(1 - v_x^2)$, in order to escape. For small distances, where the angular momentum term dominates, the motion changes direction at smaller r , as the radial motion of the string is slower than in the $v_x = 0$ case. Note that as $v_x \rightarrow 1$ we must have $\dot{r} \rightarrow 0$, due to the constraint $1 - v^2 > 0$ arising from the square root in the action (4.3).

Let us now compare our results with the findings of the previous section. There is general agreement in the type of orbits that can arise, namely deflections, bounces and bound orbits, but there are also some important differences. In particular, in this section the 3D velocities v_x were constant, while in section 3 there was a weak dependence of v_x on the internal velocity v_ℓ . By looking at equation (3.9), this dependence can be traced to the string curvature and Hubble friction terms. While the macroscopic model of the previous section enabled us to allow for correlation-scale curvature giving rise to rms string 3D velocities, here we have considered a

straight string with zero curvature. The most important difference with the previous section is the inclusion of friction terms due to cosmic expansion. This, for example, changes the dependence of the orbits on v_x , as, in the case of no friction, a small v_x generally implies a larger value for the radial velocity in the internal dimensions (as we just saw), but when one includes Hubble friction a small v_x also comes with a stronger damping term on v_ℓ , which can lead to a smaller internal velocity (Fig. 3). Here, there is no Hubble friction in the 10D picture, since the metric is a warped product of Minkowski (as opposed to FLRW in section 3) spacetime with a compact internal manifold.

To make contact with the previous section, we can move to an effective 4D description by ‘integrating out’ the compact dimensions on the worldsheet action. Splitting the metric into a 4D and an internal part, $g_{\mu\nu}^{(4)}$ and $g_{\ell m}^{(6)}$ respectively (which include the relevant warping factors), the induced metric on the worldsheet is:

$$\gamma_{\alpha\beta}^{(10)} = g_{\mu\nu}^{(4)} \partial_\alpha x^\mu \partial_\beta x^\nu + g_{\ell m}^{(6)} \partial_\alpha l^\ell \partial_\beta l^m. \quad (4.16)$$

Defining the induced 4D metric as

$$\gamma_{\alpha\beta}^{(4)} = g_{\mu\nu}^{(4)} \partial_\alpha x^\mu \partial_\beta x^\nu, \quad (4.17)$$

one can factorise it in the worldsheet Lagrangian, to obtain an effective 4D string action:

$$\begin{aligned} -\frac{\mathcal{L}}{\mu} &= \sqrt{-\det\gamma^{(10)}} = \sqrt{-\det[\gamma_{\alpha\beta}^{(4)}(\delta_\gamma^\beta + \gamma_{(4)}^{\beta\delta} \partial_\delta l^\ell \partial_\gamma l^m g_{\ell m}^{(6)})]} \\ &= \sqrt{-\det\gamma^{(4)}} \sqrt{\det(\delta_\gamma^\beta + \gamma_{(4)}^{\beta\delta} \partial_\delta l^\ell \partial_\gamma l^m g_{\ell m}^{(6)})}. \end{aligned} \quad (4.18)$$

Then, using

$$\det(\mathbf{1} + \mathbf{M}) = 1 + \frac{1}{2}\text{Tr}(\mathbf{M}) - \frac{1}{4}\text{Tr}(\mathbf{M}^2) + \frac{1}{8}(\text{Tr}\mathbf{M})^2 + \mathcal{O}(\mathbf{M}^3), \quad (4.19)$$

one finds kinetic terms for the worldsheet scalar fields l^ℓ .

One can similarly obtain a low-energy Einstein-Hilbert term, starting from the 10D gravitational action. The 4D metric will then couple to any scalar fields arising from the compactification. In the setups we are interested in, all scalar fields are stabilised except one, which corresponds to the position of a mobile D -brane moving towards an anti- D -brane at the bottom of the warping throat. The interaction between the brane-anti-brane pair, gives rise to a potential for the scalar field, which, subject to fine tuning, can satisfy the slow-roll conditions for inflation. Thus, as the branes approach each other, the scalar field drives inflation in the effective 4D description. The inflationary phase ends with the collision of the branes and the production of an interacting network of cosmic D - and F -strings [6, 7]. The universe

enters a radiation-dominated era, so the strings soon find themselves evolving in a power-law FLRW, rather than inflationary, background.

We can then understand the essence of our previous results also in this picture: firstly, the string action we found contains kinetic terms for worldsheet scalar fields l^ℓ , which from the 10D point of view correspond to the positions of the strings in the internal manifold. These can be thought of as worldsheet currents, which are known to result in a reduction of the velocity of strings [38]. We found the same effect from the 10D point view in section 3, where some of the kinetic energy of the string was in the internal directions, so the 3D motion of strings was reduced as a result of the constraint $v^2 \lesssim 1$ (local) or $v^2 \lesssim 1/2$ (for rms velocities in networks) [18]. Further, as the strings evolve in an expanding background, there is Hubble friction, which could in principle kill these worldsheet excitations. In the 10D picture, we found, by considering the string equations of motion, that Hubble damping in the expanding dimensions couples only weakly to the internal excitations and is insufficient to damp them away. From the low-energy point of view we have just considered, this is still the case because Hubble damping is important on large scales, while the worldsheet scalar excitations operate over much shorter length-scales, over which the background can be taken to be flat. Further, Hubble damping is becoming less and less important (scaling as t^{-1}) on fixed scales, so it can only have a transient effect at early times. This is in sharp contrast with the case of inflation, where damping can have a much more significant impact (Fig. 2).

5. Discussion

Let us summarise and comment on our results. In the first part of this paper, we investigated the effect of warping on string evolution, in the case where the background is a warped product of a FLRW universe with a static, toroidal internal space. Starting from the Nambu-Goto equations of motion for strings evolving in this warped background, we identified a number of extra terms that tend to pull the strings towards the bottom of the throat. We then obtained equations for the velocity evolution of string segments, and, by solving them near the minimum of a warping potential, we quantified the tendency of strings to move towards the minimum. We noted that, in classical theory, there is not enough damping to guarantee that the strings actually reach the potential minimum and stabilise. Instead, our analysis supports a picture in which strings oscillate around the bottom, being only weakly damped by cosmological expansion, rather than quickly migrating to it. During these oscillations, we have found that the 3D string velocity v_x also exhibits oscillatory modulation in its magnitude, due to its coupling to v_ℓ , but this effect is too small to be of observational significance. Including angular momentum, and considering different initial conditions, we have found a number of different string trajectories that include deflections, bounces, and bound orbits around the minimum.

We then moved on to study string motion in 10D warped backgrounds, like the ones arising in IIB compactifications in brane inflation, where the metric is a warped product of Minkowski spacetime and a Calabi-Yau manifold. Through a qualitative analysis in terms of an effective potential for one-dimensional radial motion, we found similar string trajectories. Then, by integrating out the internal dimensions, we obtained kinetic terms of worldsheet scalars, corresponding to the internal string positions in the 10D picture. In the effective 4D picture, one can then understand the effect of slowing down of strings from a slightly different point of view, namely in terms of worldsheet currents as in superconducting strings. Hubble friction is then inefficient on short scales and decays as t^{-1} during radiation/matter domination.

In both pictures, our classical analysis points out the absence of strong enough damping to ensure that a generic string trajectory around the potential minimum would be one spiraling towards it, losing energy on the way, and falling on it. Instead, we find that generic trajectories near the tip involve series of bounces/deflections with insignificant kinetic energy damping. This could clearly have important implications for string evolution, in particular it could further reduce the average probability of string intercommutations [15, 16]. The effect may not be as dramatic as it looks at first sight, because, in the typical brane inflation setup, the branes collide at the tip of the throat, and so the strings are actually produced close to the bottom. Thus, if the energy of the produced string is not enough to escape the potential pull, the string can enter a series of bounces, or a bound orbit, its motion being confined within a maximum distance from the centre. However, depending on the initial internal velocity of the string, this distance may be large enough for it to be a bad approximation to consider the string located at the bottom. It is also possible to produce strings with enough energy to escape the throat region, though this looks statistically unlikely. Indeed, a simple classical estimate obtained by comparing the string potential and kinetic energies (arising from expanding the energy (4.5) in powers of $v_\ell^2 \equiv h(r)(g_{rr}\dot{r}^2 + g_{\theta\phi}\dot{\theta}\dot{\phi})$ to write it as rest mass plus potential and kinetic energy), suggests that the string will escape for $v_\ell^2 \gtrsim (h-1)(1-v_x^2)$. Deep in the warping potential where $(h-1) \gg 1$, this is a rare possibility for a scaling network, as there is a ‘Virial theorem’ imposing that $v_x^2 + v_\ell^2 \simeq 1/2$. However, since we are now considering strings that were just produced with velocities v_x, v_ℓ at the brane collision and had no time to ‘virialise’, this condition does not apply. Unfortunately, the details of the brane collision and annihilation process are at present poorly understood and one cannot quantify the transverse velocity distribution of the produced strings. Presumably, the collision is highly non-adiabatic, giving rise to significant string velocities in the transverse directions, but, due to the Brownian 3D spatial structure of the produced network and local energy conservation, these are expected to be subdominant compared to the corresponding 3D velocities [18].

It follows, therefore, that the main concern here is not about the strings escaping the warping potential, but, rather, entering a series of bounces and deflections

about the bottom of the throat, remaining within a maximum distance from it. This distance defines a volume factor, which suppresses the string intercommuting probability. Under the assumption that the strings are localised at the bottom of the throat, the corresponding volume factor appearing in the relevant string amplitude is determined by the ‘thickness’ of the string, or better the extend of the wavefunction characterising the fluctuations of the string position around the bottom [16, 17], which is of order few string lengths. Here, the volume factor can be much larger due to the classical motion of the string, the relevant distance scale being much greater than the string scale⁴. Therefore, depending on the details of the brane collision occurring in the final stages of brane inflation (in particular, on the energy transferred to translational degrees of freedom in the internal dimensions), the intercommuting probabilities for cosmic superstrings may be further reduced, with potentially important implications for string network scaling values [15, 20, 19]. Given the uncertainties in the details of the final stages of brane inflation—in particular the collision and annihilation of the branes—it is not possible at present to quantify the expected suppression in the intercommuting probability. It is clear, however, from the above discussion that this suppression can easily be of one order of magnitude or more. Thus, combined with recent evidence [19, 39] that the scaling string density goes with $P^{-2/3}$ (weaker than initially anticipated), the effects discussed in this paper would push up the predicted string densities in these scenarios closer to the initially anticipated levels, obtained by using a larger probability P but stronger dependence of ρ on P .

The key point of the no-damping result obtained in this study is that the Nambu-Goto equations of motion imply that Hubble friction in the internal dimensions comes with a velocity-dependent coefficient, which quickly goes to zero as string velocities evolve. Any other damping term which could operate over cosmological timescales would be enough to ensure string stabilisation at the bottom of the throat, though it seems difficult to motivate such a friction mechanism in classical theory. One may wonder whether some other mechanism could operate in quantum theory, providing an efficient damping term. An interesting possibility would be quantum decay to lighter particles, but one would need to know in detail how the worldsheet scalars couple to the standard model and/or other light fields.

Acknowledgments

The work presented here was initiated by a question of G. Efstathiou. I would like to thank Paul Shellard for collaboration during the early stages of this project. This paper has also benefited from discussions with Fernando Quevedo, Jose Blanco-Pillado and Ivonne Zavala. I would like to thank Ed Copeland and Anne Davis for their

⁴It is, of course, still smaller than the compactification scale.

comments and encouragement. I acknowledge financial support from the Cambridge Newton Trust and the EC Marie Curie Research Training Network ENRAGE. This work is also supported in part by MEC, research grant FPA2007-66665.

References

- [1] T. W. B. Kibble, *Cosmic strings reborn?*, [astro-ph/0410073](#).
- [2] J. Polchinski, *Introduction to cosmic f- and d-strings*, [hep-th/0412244](#).
- [3] A. C. Davis and T. W. B. Kibble, *Fundamental cosmic strings*, *Contemp. Phys.* **46** (2005) 313–322, [[hep-th/0505050](#)].
- [4] R. Jeannerot, J. Rocher, and M. Sakellariadou, *How generic is cosmic string formation in susy guts*, *Phys. Rev.* **D68** (2003) 103514, [[hep-ph/0308134](#)].
- [5] S. Sarangi and S. H. H. Tye, *Cosmic string production towards the end of brane inflation*, *Phys. Lett.* **B536** (2002) 185–192, [[hep-th/0204074](#)].
- [6] G. Dvali and A. Vilenkin, *Formation and evolution of cosmic d-strings*, *JCAP* **0403** (2004) 010, [[hep-th/0312007](#)].
- [7] E. J. Copeland, R. C. Myers, and J. Polchinski, *Cosmic f- and d-strings*, *JHEP* **06** (2004) 013, [[hep-th/0312067](#)].
- [8] A. D. Linde, *Hybrid inflation*, *Phys. Rev.* **D49** (1994) 748–754, [[astro-ph/9307002](#)].
- [9] J. Urrestilla, A. Achúcarro, and A. C. Davis, *D-term inflation without cosmic strings*, *Phys. Rev. Lett.* **92** (2004) 251302, [[hep-th/0402032](#)].
- [10] A. Albrecht, R. A. Battye, and J. Robinson, *The case against scaling defect models of cosmic structure formation*, *Phys. Rev. Lett.* **79** (1997) 4736–4739, [[astro-ph/9707129](#)].
- [11] A. Albrecht, R. A. Battye, and J. Robinson, *A detail study of defect models for cosmic structure formation*, *Phys. Rev.* **D59** (1999) 023508, [[astro-ph/9711121](#)].
- [12] N. Bevis, M. Hindmarsh, M. Kunz, and J. Urrestilla, *Fitting cmb data with cosmic strings and inflation*, [astro-ph/0702223](#).
- [13] R. A. Battye, B. Garbrecht, and A. Moss, *Constraints on supersymmetric models of hybrid inflation*, *JCAP* **0609** (2006) 007, [[astro-ph/0607339](#)].
- [14] R. A. Battye, B. Garbrecht, A. Moss, and H. Stoica, *Constraints on Brane Inflation and Cosmic Strings*, *JCAP* **0801** (2008) 020, [[arXiv:0710.1541](#)].
- [15] N. T. Jones, H. Stoica, and S. H. H. Tye, *The production, spectrum and evolution of cosmic strings in brane inflation*, *Phys. Lett.* **B563** (2003) 6–14, [[hep-th/0303269](#)].

- [16] M. G. Jackson, N. T. Jones, and J. Polchinski, *Collisions of cosmic f- and d-strings*, *JHEP* **10** (2005) 013, [[hep-th/0405229](#)].
- [17] M. G. Jackson, *Cosmic superstring scattering in backgrounds*, *JHEP* **09** (2006) 071, [[hep-th/0608152](#)].
- [18] A. Avgoustidis and E. P. S. Shellard, *Cosmic string evolution in higher dimensions*, *Phys. Rev.* **D71** (2005) 123513, [[hep-ph/0410349](#)].
- [19] A. Avgoustidis and E. P. S. Shellard, *Effect of reconnection probability on cosmic (super)string network density*, *Phys. Rev.* **D73** (2006) 041301, [[astro-ph/0512582](#)].
- [20] M. Sakellariadou, *A note on the evolution of cosmic string / superstring networks*, *JCAP* **0504** (2005) 003, [[hep-th/0410234](#)].
- [21] S. Kachru, R. Kallosh, A. Linde, J. Maldacena, L. McAllister, and S. P. Trivedi, *Towards inflation in string theory*, *JCAP* **0310** (2003) 013, [[hep-th/0308055](#)].
- [22] C. J. A. P. Martins and E. P. S. Shellard, *Quantitative string evolution*, *Phys. Rev.* **D54** (1996) 2535–2556, [<http://arXiv.org/abs/hep-ph/9602271>].
- [23] C. J. A. P. Martins and E. P. S. Shellard, *Extending the velocity-dependent one-scale string evolution model*, *Phys. Rev.* **D65** (2002) 043514, [<http://arXiv.org/abs/hep-ph/0003298>].
- [24] G. Dvali and S. H. H. Tye, *Brane inflation*, *Phys. Lett.* **B450** (1999) 72, [[hep-ph/9812483](#)].
- [25] G. Dvali, Q. Shafi, and S. Solganic, *D-brane inflation*, [hep-th/0105203](#).
- [26] C. P. Burgess, M. Majumdar, F. Quevedo, G. Rajesh, and R.-J. Zhang, *The inflationary brane-antibrane universe*, *JHEP* **0107** (2001) 047, [[hep-th/0105204](#)].
- [27] J. Garcia-Bellido, R. Rabadan, and F. Zamora, *Inflationary scenarios from branes at angles*, *JHEP* **01** (2002) 036, [[hep-th/0112147](#)].
- [28] N. Jones, H. Stoica, and S. H. H. Tye, *Brane interaction as the origin of inflation*, *JHEP* **0207** (2002) 051, [[hep-th/0203163](#)].
- [29] A. Avgoustidis, *Cosmic string evolution in brane inflation*, . PhD Thesis, University of Cambridge.
- [30] A. Krause and E. Pajer, *Chasing Brane Inflation in String-Theory*, [arXiv:0705.4682](#).
- [31] D. Baumann, A. Dymarsky, I. R. Klebanov, and L. McAllister, *Towards an explicit model of d-brane inflation*, [0706.0360](#).
- [32] I. R. Klebanov and A. A. Tseytlin, *Gravity duals of supersymmetric $su(n) \times su(n+m)$ gauge theories*, *Nucl. Phys.* **B578** (2000) 123–138, [[hep-th/0002159](#)].

- [33] I. R. Klebanov and M. J. Strassler, *Supergravity and a confining gauge theory: Duality cascades and chiral-resolution of naked singularities*, *JHEP* **08** (2000) 052, [[hep-th/0007191](#)].
- [34] D. Kutasov, *D-brane dynamics near ns5-branes*, [hep-th/0405058](#).
- [35] S. Kachru and L. McAllister, *Bouncing brane cosmologies from warped string compactifications*, *JHEP* **03** (2003) 018, [[hep-th/0205209](#)].
- [36] C. Germani, N. E. Grandi, and A. Kehagias, *A stringy alternative to inflation: The cosmological slingshot scenario*, [hep-th/0611246](#).
- [37] D. Easson, R. Gregory, G. Tasinato, and I. Zavala, *Cycling in the throat*, *JHEP* **04** (2007) 026, [[hep-th/0701252](#)].
- [38] A. Vilenkin and E. P. S. Shellard, *Cosmic Strings and Other Topological Defects*. Cambridge University Press, 1994.
- [39] V. Vanchurin, *Cosmic string loops: large and small, but not tiny*, *Phys. Rev.* **D77** (2008) 063532, [[arXiv:0712.2236](#)].