

Secure quantum channels with correlated twin laser beams

Constantin V. Usenko[†] and Vladyslav C. Usenko^{‡§}

[†] National Shevchenko University of Kyiv, Department of Theoretical Physics, Kyiv, Ukraine

[‡] Institute of Physics of National Academy of Science, Kyiv, Ukraine

Abstract. This work is the development and analysis of the recently proposed quantum cryptographic protocol, based on the use of the two-mode coherently correlated states. The protocol is supplied with the cryptographic control procedures. The quantum noise influence on the channel error properties is examined. State detection features are proposed.

PACS numbers: 03.67.Dd, 03.67.Hk, 42.50.Ar, 42.50.Dv

1. Introduction.

The goals of quantum cryptography and secure quantum communications [1, 2, 3] can be achieved using various protocols, which were developed and realized [7, 12] in the past years on the basis of the quantum entanglement [5, 7] of weak beams and the single [9, 10] or few photon states [11], mostly by means of adjusting and detecting their polarization angles [13].

Another method, based on the usage of the two-mode coherently correlated (TMCC) beams was proposed recently [6]. In this case the secure cryptographic key is generated by the laser shot noise and duplicated through the quantum channel. Unlike the single or few photon schemes, which require large numbers of transmission reiterations to obtain the statistically significant results, the TMCC beam can be intensive enough to make each single measurement statistically significant and thus to use single impulse for each piece of information, and remain cryptographically steady.

In this work we analyse the error properties of the secure quantum channels, based on the TMCC-beams and propose some additions to the TMCC-based cryptographic protocol.

The two-mode coherently correlated state is the way we refer to the generalized coherent state in the meaning by Perelomov [4]. Such state can be described by its

§ To whom correspondence should be addressed (usenko@univ.kiev.ua)

presentation through series by Fock states:

$$|\lambda\rangle = \frac{1}{\sqrt{I_0(2|\lambda|)}} \sum_{n=0}^{\infty} \frac{\lambda^n}{n!} |nn\rangle \quad (1)$$

Here we use the designation $|nn\rangle = |n\rangle_1 \otimes |n\rangle_2$, where $|n\rangle_1$ and $|n\rangle_2$ stand for the states of the 1st and 2nd modes accordingly, represented by their photon numbers. The states (1) are not the eigenstates for each of the operators separately, but are the eigenstates for the product of annihilation operators:

$$a_1 a_2 |\lambda\rangle = \lambda |\lambda\rangle. \quad (2)$$

Such states can also be obtained from the zero state:

$$|\lambda\rangle = \frac{1}{\sqrt{I_0(2|\lambda|)}} I_0(\lambda a_1^+ a_2^+) |0\rangle \quad (3)$$

In this work we assume that two laser beams, which are propagating independently from each other, correspond to the two modes of the TMCC state. States of beams are mutually correlated (surely, the TMCC state can also be represented in another way, for example, as a beam consisting of two correlated polarizations).

2. Beam measurement

Let's examine any of the two TMCC beams separately. The intensity of the beam's radiation, registered by an observer is proportional to the mean of the $N = a^+ a$ operator, which is the number of the photons in the corresponding mode. The mean observable values, which characterize the results of the measurements of the beam are:

$$\langle N \rangle = \langle \lambda | a^+ a | \lambda \rangle, \langle N^2 \rangle = \langle \lambda | a^+ a a^+ a | \lambda \rangle \quad (4)$$

These characteristics are squared in field, and thus their mean values don't turn to zero (this fact is not specific for the TMCC-states, because the usual non-correlated states and processes, like the heat propagation, show the same properties).

Assuming the state expression (1) we obtain

$$\langle N \rangle = \frac{1}{I_0(2|\lambda|)} \sum_{n=0}^{\infty} n \frac{|\lambda|^{2n}}{n!^2}, \langle N^2 \rangle = \frac{1}{I_0(2|\lambda|)} \sum_{n=0}^{\infty} n^2 \frac{|\lambda|^{2n}}{n!^2} \quad (5)$$

The mean number of registered photons is

$$\langle N \rangle = \sum_{n=0}^{\infty} n P_n(\lambda) \quad (6)$$

The probability of registering n photons depends on the intensity of a beam:

$$P_n(\lambda) = \frac{1}{I_0(2|\lambda|)} \frac{|\lambda|^{2n}}{n!^2} \quad (7)$$

An important feature of this distribution is the quick (proportional to $n!^2$) decreasing dependence of the registration probability on the photon number.

This circumstance makes the experimental identification of the TMCC-states quite convenient. The distribution of the probability of different photon numbers registration along with the analogous distribution for a usual coherent beam are given at the figure 1. One can see that there are significant differences for the TMCC and the Poisson beam distributions - the TMCC-beam distribution is relatively sharp and narrow.

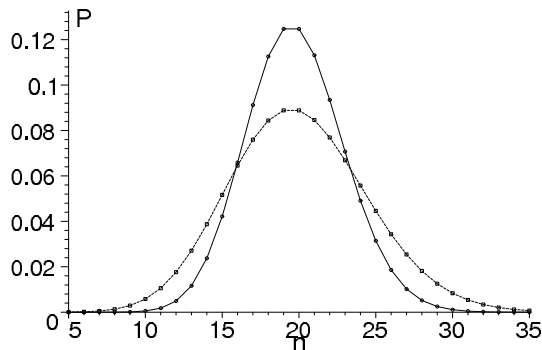

Figure 1. Probability of different photon numbers registration distribution for the TMCC-beam (circles, solid line) and the analogous distribution for a usual coherent beam (squares, dotted line)

Taking into account (7) the expressions for the mean and mean square values of the registered photon numbers (5) turn to:

$$\langle N \rangle = \frac{|\lambda|^2 I_1(2|\lambda|)}{I_0(2|\lambda|)}, \langle N^2 \rangle = |\lambda|^2 \quad (8)$$

The measurements have the statistical uncertainty, caused by quantum fluctuations. This uncertainty can be characterized by the corresponding dispersion:

$$\sigma^2 = \langle N^2 \rangle - \langle N \rangle^2 \quad (9)$$

Taking into account (8) we get the following expression:

$$\sigma^2 = |\lambda|^2 \left(1 - \left(\frac{I_1(2|\lambda|)}{I_0(2|\lambda|)} \right)^2 \right) \quad (10)$$

The dependencies of the measurement results uncertainty on the mean photon number for the TMCC-beam and a usual correlated beam are given at figure 2. The difference between these dependencies can also be used for the TMCC-states identification.

3. Communication via quantum channel

Let us have to establish a secure quantum channel between two parties (figure 3). Alice has the laser on her side, which produces two beams in the TMCC state. The optical channel is organized in such a way, that Alice receives one of the modes, the first, for

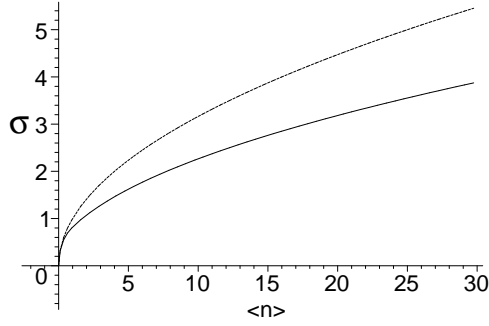

Figure 2. The dependencies of the measurement results uncertainty on the mean photon number for the TMCC-beam (solid line) and a usual coherent beam (dotted line)

example, i.e. $\varphi_A \equiv \varphi_1, \varphi_A(x_A, t_0) = 1$, and Bob receives another one, i.e. $\varphi_B \equiv \varphi_2, \varphi_B(x_B, t_0) = 1$ at any moment of measurement t_0 , where x_A and x_B are Alice's and Bob's locations respectively. Accordingly, Alice cannot measure the Bob's beam and vice versa: $\varphi_B(x_A, t_0) = 0, \varphi_A(x_B, t_0) = 0$. At that the vector-potential of the TMCC-beam is:

$$A = \varphi_A^*(x, t)a_A^\dagger + \varphi_A(x, t)a_A + \varphi_B^*(x, t)a_B^\dagger + \varphi_B(x, t)a_B \quad (11)$$

Unlike the usual non-correlated coherent states, which show their quasiclassical properties in the fact, that the mean value of a vector-potential of a corresponding beam is not equal to 0, the mean value of a vector-potential of a TMCC-beam and any other characteristic, which is linear in field, turns to be equal to 0, because during the averaging by the 1st mode, for example, the a_1 converts $|n, n\rangle$ to $|n-1, n\rangle$, which is orthogonal to all the present state terms, so $\langle \lambda_i | a_i | \lambda_i \rangle = 0$. So the quasiclassical properties in their usual meaning are absent in the case of a TMCC-beam. But they become apparent in the non-zero value of the spatial correlation function, which characterizes the interdependence of the results of measurements taken by Alice and Bob:

$$g_{AB} = \langle N_A N_B \rangle - \langle N_A \rangle \langle N_B \rangle \quad (12)$$

It's useful to describe the channel quality by the relative correlation, which is

$$\rho_{AB} = \frac{\langle N_A N_B \rangle - \langle N_A \rangle \langle N_B \rangle}{\sigma_A \sigma_B} \quad (13)$$

The main feature of the TMCC state is that the value ρ_{AB} is exactly equal to 1, while in the case of non-correlated beams we would get $\rho_{AB} = 0$. This means that the measurements of the photon numbers, obtained by Alice and Bob, each with her/his own detector, not only show the same mean values, but even have the same deflection from the mean values.

The laser beam is the semi-classical radiation with well defined phase, but due to the uncertainty principle for the number of photons and the phase of the radiation, there is a large enough uncertainty in the photon numbers, this can be seen from the

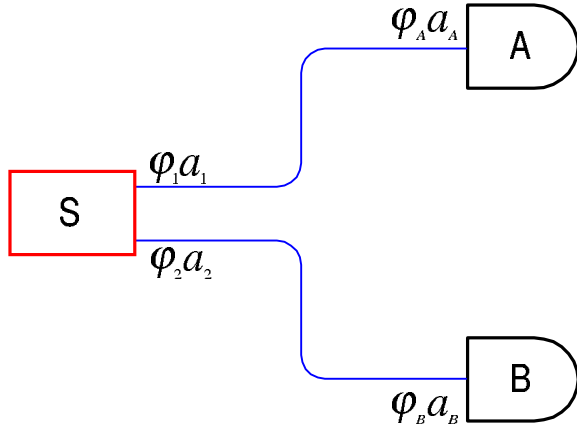

Figure 3. Quantum channel between two parties with a TMCC source

dispersion expression (10). Thus one can observe the noise, which is similar to the shot noise in an electron tube. In the TMCC radiation the characteristics of such noise for each of the modes are amazingly well correlated to each other. This fact enables the use of such radiation for generation of a random code, which will be equally good received by two mutually remote detectors.

3.1. The protocol

The following scheme can be used for the TMCC-based protocol. The laser is set up to produce the constant mean number of photons during the session and both parties know this number. At some moment Alice and Bob start the measurements. They detect the number of photons at unit time by measuring the integrated intensity of the corresponding incoming beam. If the number of photons for the specific unit time is larger than the known expected mean (which is due to the shot noise), the next bit of the generated code is considered to have the value “1”. If the measured number is less than the expected mean, the next bit is considered to be equal to “0”:

$$B = \begin{cases} \{n \leq [\langle N \rangle]\} \rightarrow 0 \\ \{n > [\langle N \rangle]\} \rightarrow 1 \end{cases} \quad (14)$$

Upon the receipt of a sufficient number of bits (the code), both Bob and Alice divide them in half, each obtaining two bit sequences (half-codes). Bob encodes one sequence with another, using the “eXclusive OR” logical operation (XOR, $B_i \oplus B_j$), and sends this encoded half-code to Alice using any public channel. Alice uses any of her half-codes to decode the code she has got from Bob using the same XOR operation. She compares the result of this operation with another of her half-codes. If all the bits coincide, this means that Alice and Bob both have the same code, which can be used as a cryptographic key for encoding their communication. Otherwise they have to repeat the key generation and transfer procedure and check the channel for the possible eavesdropping if the procedure fails again.

The stability of the protocol against the basic beam splitting attacks was examined in [6] and it was shown that any successful attempt destroys the channel and cancels the key distribution session. Besides the basic listening-in, Eve may carry out a more advanced state cloning eavesdropping attack by detecting the overall photon number in the Bob's mode for each upcoming bit and then re-emitting the same number again, which requires Eve to have the same laser source on her site. Though, due to the laser shot noise Eve can't be sure if she is producing exactly the same number of photons, she can set up her laser just to produce some mean photon number. In case she will adjust her laser to produce the mean photon number, which is equal to the current photon number measured in the Bob's mode for a next bit, she may probably be successful by repeating some bits. But in this case she will change the Bob's measurement results distribution. This can be checked by expanding a protocol with a post-measurement analysis of the measurement results, which can be done by both of the trusted parties. It should consist of the comparison of an obtained photon numbers distribution by the frequencies of their detection with the expected one for the known constant mean photon number value which is actually a task of comparing two numerical arrays. The difference between expected and obtained distributions will reveal a state cloning attempt.

3.2. Quantum channel error analysis

Let the parties of the secret key transmission procedure are using the protocol described above, thus they estimate the value of the next bit by comparing the actual registered photon number to the average. The probability of detecting "0" bit value then is

$$P_{(0)}(\lambda) = \sum_{n=0}^{[N]} P_n(\lambda) \quad (15)$$

The noise is present in the channel and it may increase the number of the registered photons. We suppose that the noise is thermal and assume that it may, with some probability, cause an appearance of one and no more than one additional photon in any of the modes during the time of a bit detection. We will denote the probability of a noise photon detection as ϵ and refer to it as the noise factor.

We suppose that the channel is qualitative enough to transfer the impulse at the required distance without losing any single photon, thus errors are possible only due to the appearance of the noise photons.

An error, when Alice registers "0" bit value and Bob registers "1" may occur upon the joint realization of two events. The first is that Alice detects the maximum possible number of these, corresponding to the "0" bit value, which is, according to the proposed protocol, equal to the integer part of $\langle n \rangle$. The second is that in addition to this number Bob detects the appearance of a noise photon. The opposite situation, when Alice gets the "1" bit value and Bob registers "0" is possible when the noise photon was detected by Alice, the probability of such error is the same.

The probability of the realization of a state, which consists of the maximum possible for the "0" bit value photons and, at the same time, is detected as "0", is the relation between the corresponding probabilities:

$$P_{max(0)} = \frac{P_{[\langle N \rangle]}}{P_{(0)}} = \frac{P_{[\langle N \rangle]}}{\sum_{n=0}^{[\langle N \rangle]} P_n(\lambda)} \quad (16)$$

We will refer to this probability as to the error factor. So the probability of an error during the bit registration is equal to the product of the noise and error factors:

$$P_{err(0)}(\lambda) = \epsilon P_{max(0)} \quad (17)$$

One can easily see that upon the intensity increase the error factor becomes less and so the channel tends to a self-correction if the beam gets more intensive.

4. Conclusions

Correlated coherent states of the two-mode laser beam (TMCC states) show interesting properties, which can be used, in particular, for the tasks of the quantum communication and cryptography.

The TMCC-beams can be identified due to the special form of the registration probabilities distribution for different photon numbers in the corresponding beam and the dependence of the dispersion on the mean photon numbers value.

On the one hand, each of the modes looks like a flow of the independent photons rather than a coherent beam, since mean values of the operators, which are linear in field, are equal to 0 for each mode separately.

On the other hand, the strong correlation between the results of measurements for each of the modes takes place. This correlation shows itself in the fact that in each of the modes numbers of photons are the same and even the shot noise shows itself equally in the both modes. This enables the use of the TMCC state as the generator and carrier of random keys in a quantum channel which is stable against the eavesdropping [6].

Thus, the TMCC-laser generates and transmits exactly the 2 copies of a random key. Unlike the single or two-photon schemes, which require large numbers of transmission reiterations to obtain the statistically significant results, the TMCC beam can be intensive enough to make each single measurement statistically significant and thus to use single impulse for each piece of information, and remain cryptographically steady. This allows to essentially increase the effective data transfer rate and distance. Analysis of the noise influence on the channel properties shows that the channel tends to a self-correction upon the beam intensity increase.

References

- [1] Nicolas Gisin, Gregoire Ribordy, Wolfgang Tittel, Hugo Zbinden. Quantum Cryptography. Preprint: quant-ph/0101098

- [2] Matthias Christandl, Renato Renner, Artur Ekert. A Generic Security Proof for Quantum Key Distribution. Preprint: quant-ph/0402131
- [3] Nicolas Gisin, Nicolas Brunner. Quantum cryptography with and without entanglement. Preprint: quant-ph/0312011
- [4] A. Perelomov, Generalized Coherent States and Their Applications (Springer, Berlin, 1986).
- [5] Wolfgang Tittel, Gregor Weihs. Photonic Entanglement for Fundamental Tests and Quantum Communication. quant-ph/0107156
- [6] Constantin V. Usenko and Vladyslav C. Usenko. Preprint: quant-ph/0403112 (submitted to Journal of Russian Laser Research)
- [7] A. Ekert, Phys. Rev. Lett. 67, 661 (1991)
- [8] D. S. Naik et al., Phys. Rev. Lett. 84, 4732 (2000)
- [9] C. H. Bennett, Phys. Rev. Lett. 68, 3121 (1992)
- [10] C. K. Hong and L. Mandel, Phys. Rev. Lett. 56, 58 (1986)
- [11] C. H. Bennett and G. Brassard, Quantum cryptography: public key distribution and coin tossing, Int. conf. Computers, Systems & Signal Processing, Bangalore, India, 1984, 175- 179.
- [12] T. Jennewein et al., Phys. Rev. Lett. 84, 4729 (2000)
- [13] A.C. Funk, M.G. Raymer. Quantum key distribution using non-classical photon number correlations in macroscopic light pulses. Preprint: quant-ph/0109071
- [14] Yun Zhang, Katsuyuki Kasai, Kazuhiro Hayasaka. Quantum channel using photon number correlated twin beams. quant-ph/0401033, Optics, Express 11, 3592 (2003)
- [15] L. A. Wu, H. J. Kimble, J. L. Hall, and H. F. Wu, Generation of squeezed states by parametric down conversion, Phys. Rev. Lett. 57, 2520-2524 (1986).
- [16] H. Wang, Y. Zhang, Q. Pan, H. Su, A. Porzio, C. D. Xie, and K. C. Peng, Experimental realization of a quantum measurement for intensity difference fluctuation using a beam splitter, Phys. Rev. Lett. 82, 1414-1417 (1999).